



Center for Academic Resources in Engineering (CARE) Peer Exam Review Session

Math 241 – Calculus III

CBTF Midterm 5 Worksheet

The problems in this review are designed to help prepare you for your upcoming exam. Questions pertain to material covered in the course and are intended to reflect the topics likely to appear in the exam. Keep in mind that this worksheet was created by CARE tutors, and while it is thorough, it is not comprehensive. In addition to exam review sessions, CARE also hosts regularly scheduled tutoring hours.

Tutors are available to answer questions, review problems, and help you feel prepared for your exam during these times:

Session 1: May 3, 3-4:30 pm, 433 Grainger, Meredith and Rodrigo

Can't make it to a session? Here's our schedule by course:

<https://care.grainger.illinois.edu/tutoring/schedule-by-subject>

Solutions will be available on our website after the last review session that we host.

Step-by-step login for exam review session:

1. Log into Queue @ Illinois: <https://queue.illinois.edu/q/queue/845>
2. Click “New Question”
3. Add your NetID and Name
4. Press “Add to Queue”

Please be sure to follow the above steps to add yourself to the Queue.

Good luck with your exam!

1. Consider the following vector fields $\vec{F}(x, y, z)$. Are they conservative? If so, find a function $f(x, y, z)$ so that $\nabla f = \vec{F}$. If not, justify your response.

(a) $\vec{F}(x, y, z) = \langle yz, xz, xy + 2z \rangle$

(b) $\vec{F}(x, y, z) = \langle y + e^x, x - \cos y, 4 + z \rangle$

(c) $\vec{F}(x, y, z) = \langle y, z^2, x \rangle$

2. The vector field $\vec{F} = \langle 2xy + 2x + y^2, 2xy + 2y + x^2 \rangle$ is conservative. Find a potential function f for \vec{F} (a function with $\nabla f = \vec{F}$)

3. Let S be the surface parameterized by $\vec{r}(u, v) = \langle v \cos(u), v, v \sin(u) \rangle$ for $0 \leq u \leq 2\pi$ and $0 \leq v \leq 1$

(a) Mark the picture of S below

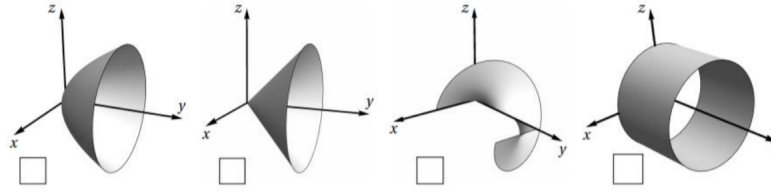

(b) Evaluate the surface integral $\iint_S y \, dS$

4. A particle moves along the upper part of an ellipse in the xy -plane that has its center at the origin with semi-major and semi-minor axes $a = 4$ and $b = 3$, respectively. Starting at $(a, 0, 0)$ and ending at $(-a, 0, 0)$ and subject to the following force field, what is the total work done?

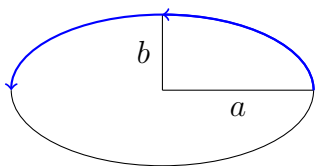

$$\vec{F} = (3x - 4y + 2z)\hat{i} + (4x + 2y - 3z^2)\hat{j} + (2xz - 4y^2 + z^3)\hat{k}$$

5. Find the work done by the force field below in moving an object from $(1,1)$ to $(2,4)$ (HINT: Check if the vector field is conservative).

$$\vec{F}(x, y) = \langle 6y^{\frac{3}{2}}, 9x\sqrt{y} \rangle$$

6. Evaluate $\int_C F \cdot dr$ where $F(x, y) = \langle 3y^2 - \cos y, x \sin y \rangle$ and C is a clockwise path shown below.

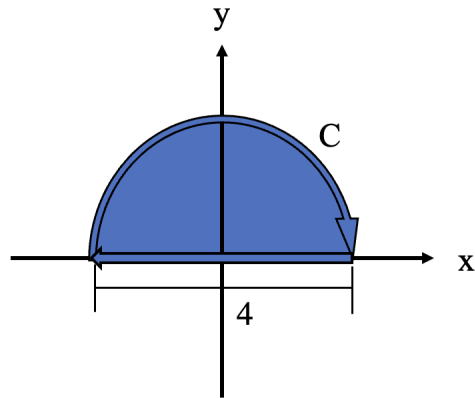

7. The graph below shows two vector fields. Answer the following questions for each of them.
- (1) Is it a conservative vector field?
 - (2) Does it have a positive, negative, or zero curl?
 - (3) Does it have a positive, negative, or zero divergence?

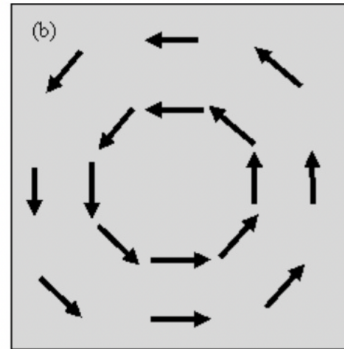
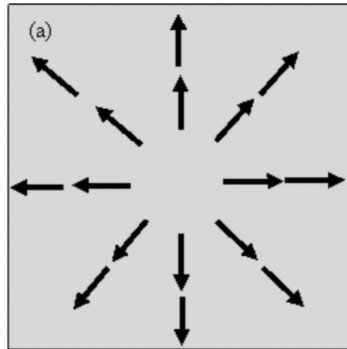

8. Evaluate the flux of the vector field $F(x, y, z) = \langle x, y, xy \rangle$ where the surface S is part of the paraboloid $z = 4 - x^2 - y^2$ that lies within $0 \leq x \leq 1, 0 \leq y \leq 1$, and is oriented upwards.

9. Evaluate $\int_C \nabla f \cdot d\vec{r}$ where $f(x, y) = ye^{x^2-1} + 4x\sqrt{y}$ and C is given by $\vec{r}(t) = \langle 1 - t, 2t^2 - 2t \rangle$ with $0 \leq t \leq 2$.

10. Compute the following surface integral $\iint_S xy \, dS$ where S is the region of the plane $x + y + z = 1$ in the first octant.

11. Use Stokes' theorem to evaluate $\int_C \vec{F} \cdot d\vec{r}$ where $\vec{F} = \langle y^2, x, z \rangle$ across the curve C shown in the figure below.

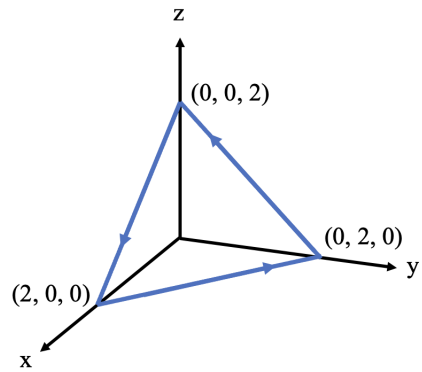

12. Use Divergence theorem to evaluate the flux of $\vec{F} = \langle x^3 + z^3, x^3 + y^3, y^3 + z^3 \rangle$ across the portion of a sphere with radius of 1 that is centered at origin and above the xy-plane.