



Center for Academic Resources in Engineering (CARE) Peer Exam Review Session

Math 241 – Calculus III

Midterm 3 Worksheet Solutions

The problems in this review are designed to help prepare you for your upcoming exam. Questions pertain to material covered in the course and are intended to reflect the topics likely to appear in the exam. Keep in mind that this worksheet was created by CARE tutors, and while it is thorough, it is not comprehensive. In addition to exam review sessions, CARE also hosts regularly scheduled tutoring hours.

Tutors are available to answer questions, review problems, and help you feel prepared for your exam during these times:

Session 1: April. 21, 5-6:50 pm Noah and Rodrigo

Can't make it to a session? Here's our schedule by course:

<https://care.grainger.illinois.edu/tutoring/schedule-by-subject>

Solutions will be available on our website after the last review session that we host.

Step-by-step login for exam review session:

1. Log into Queue @ Illinois: <https://queue.illinois.edu/q/queue/845>
2. Click “New Question”
3. Add your NetID and Name
4. Press “Add to Queue”

Please be sure to follow the above steps to add yourself to the Queue.

Good luck with your exam!

1. Making an appropriate change of variables, compute the following double integral over the region bound by a circle of radius 2 and a circle of radius 5.

$$\iint_D e^{x^2+y^2} dA$$

Using polar coordinates gives the following integral

$$\iint_D e^{x^2+y^2} dA = \int_0^{2\pi} \int_2^5 r e^{r^2} dr d\theta$$

Then using a u -substitution $u = r^2$ for the r dependence

$$\frac{1}{2} \int_0^{2\pi} \int_4^{25} e^u du d\theta = \boxed{\pi(e^{25} - e^4) \approx 2.26 \times 10^{11}}$$

2. Consider the region R :

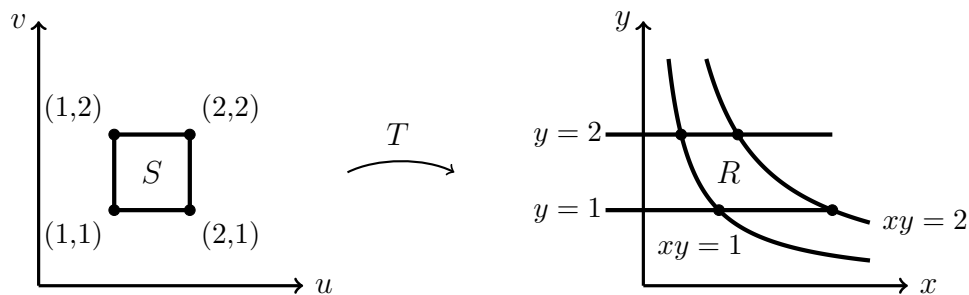

- (a) Suppose there exists a transformation $S: \mathbb{R}^2 \rightarrow \mathbb{R}^2$ from S to R . Find $T(u, v)$
- (b) Use the answer from (a) to evaluate $\iint_R x^2 dA$
- (a) It's convenient to make the substitution $v = y$ since both v and y have common lines at $v = y = 1$ and $v = y = 2$. The substitution of u would then be $u = xy$. (Check $u = 1$ and $u = 2$. They match to $xy = 1$ and $xy = 2$.)

$$v = y \in [1, 2]$$

$$u = xy \in [1, 2]$$

To solve for x , divide by y and then substitute in v for y .

$$(x, y) = T(u, v) = \left(\frac{u}{v}, v \right)$$

(b) Substitute $\frac{u}{v}$ for x and v for y calculate the Jacobian for this transformation.

$$\begin{vmatrix} \frac{\partial x}{\partial u} & \frac{\partial x}{\partial v} \\ \frac{\partial y}{\partial u} & \frac{\partial y}{\partial v} \end{vmatrix} = \begin{vmatrix} \frac{1}{v} & -\frac{u}{v^2} \\ 0 & 1 \end{vmatrix} = \frac{1}{v}$$

Note that the Jacobian matrix is taken as the absolute value of the determinant. Now calculate the integral

$$\int_1^2 \int_1^2 \left(\frac{u}{v}\right)^2 \frac{1}{v} du dv = \boxed{\frac{7}{8}}$$

3. A toilet paper manufacturing company has increased their production. Unfortunately, this production increase has caused a major manufacturing error! As you move towards the center of any one toilet paper roll, the sheets get progressively more dense. The density of a toilet paper roll can be modeled using the following function:

$$\rho(r) = \cos\left(\frac{\pi(r-1)}{6}\right) + 1$$

r is the radial distance away from the center of the roll (inside the center cardboard tube). The whole roll can be modeled as a cylinder with an outer radius of 6, and inner radius of 2 (the cardboard tube radius), and a height of 10.

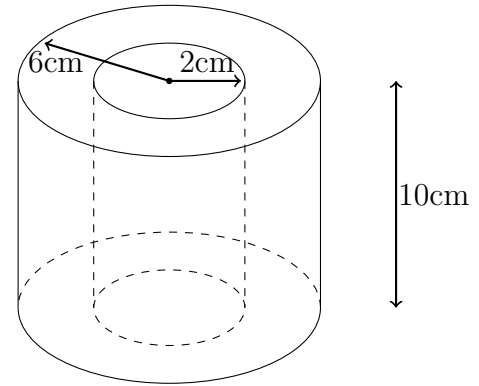

- (a) Without using a calculator, calculate the mass of the toilet paper roll if the density everywhere was just 1 (leave π in your answer)
- (b) Set up the triple integral to solve for the mass of a toilet paper roll. Neglect the weight of the inner cardboard tube for your calculation.
- (c) Without using a calculator, solve the integral (leave π in your answer)

- (a) The mass of the tube is equal to the density times the volume:

$$m = \rho V = \rho \pi (r_{outer}^2 - r_{inner}^2) h = \boxed{320\pi}$$

- (b) Cylindrical coordinates are most useful here since the figure is a cylinder. The mass is found by integrating the density with respect to dV (in cylindrical coordinates).

$$\boxed{\int_0^{10} \int_0^{2\pi} \int_2^6 \left(\cos\left(\frac{\pi(r-1)}{6}\right) + 1 \right) r \, dr d\theta dz}$$

- (c)

$$\int_0^{10} \int_0^{2\pi} \int_2^6 \left(\cos\left(\frac{\pi(r-1)}{6}\right) + 1 \right) r \, dr d\theta dz$$

$$(10)(2\pi) \int_2^6 \left(\cos\left(\frac{\pi(r-1)}{6}\right) + 1 \right) r \, dr$$

$$20\pi \left[\left(\frac{r^2}{2}\right) \Big|_2^6 + \int_2^6 \cos\left(\frac{\pi(r-1)}{6}\right) r \, dr \right]$$

Integration by parts

$$u = r, v = \frac{6}{\pi} \sin\left(\frac{\pi}{6}(r-1)\right)$$

$$20\pi \left[18 - 2 + \left(\frac{6}{\pi} \sin\left(\frac{\pi}{6}(r-1)\right)r\right)_2^6 - \int_2^6 \frac{6}{\pi} \sin\left(\frac{\pi}{6}(r-1)\right) dr \right]$$

$$20\pi \left[16 + \frac{36}{\pi} \sin\left(\frac{5\pi}{6}\right) - \frac{12}{\pi} \sin\left(\frac{\pi}{6}\right) - \int_2^6 \frac{6}{\pi} \sin\left(\frac{\pi}{6}(r-1)\right) dr \right]$$

$$20\pi \left[16 + \frac{18}{\pi} - \frac{6}{\pi} + \frac{6^2}{\pi^2} \cos\left(\frac{\pi}{6}(r-1)\right) \Big|_2^6 \right]$$

$$20\pi \left[16 + \frac{12}{\pi} + \frac{36}{\pi^2} \left(\cos\left(\frac{5\pi}{6}\right) - \cos\left(\frac{\pi}{6}\right) \right) \right]$$

$$20\pi \left[16 + \frac{12}{\pi} + \frac{36}{\pi^2} \left(-\frac{\sqrt{3}}{2} - \frac{\sqrt{3}}{2} \right) \right]$$

$$20\pi \left[16 + \frac{12}{\pi} - \frac{36\sqrt{3}}{\pi^2} \right]$$

$$\boxed{320\pi + 240 - \frac{720\sqrt{3}}{\pi}}$$

4. What is the x-coordinate of the center of mass for the shaded region if it has a density function $\rho(x, y) = 3x + 2y$? (Solve the integral by hand then evaluate the final expression with a calculator.)

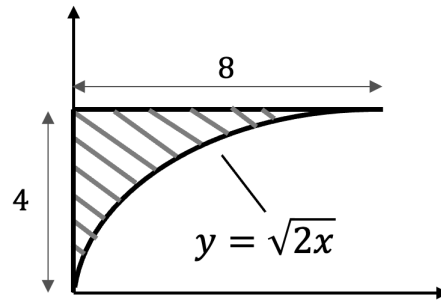

$$\bar{x} = \frac{1}{m} \iint x \rho(x, y) dA, m = \iint \rho(x, y) dA$$

$$y = \sqrt{2x} \rightarrow x = \frac{y^2}{2}$$

$$\int_0^4 \int_0^{y^2/2} x(3x + 2y) dx dy = \int_0^4 \frac{y^6}{8} + \frac{y^5}{4} dy = \frac{y^7}{56} + \frac{y^6}{24} \Big|_0^4 \approx 463.238$$

$$m = \int_0^4 \int_0^{y^2/2} (3x + 2y) dx dy = \int_0^4 \frac{3y^4}{8} + y^3 dy = \frac{3y^5}{40} + \frac{y^4}{4} \Big|_0^4 = 140.8$$

$$\bar{x} = \frac{463.238}{140.8} \approx \boxed{3.29}$$

5. Find the surface area of $z = \frac{x^2+y^2}{2}$ that lies within the cylinder $x^2 + y^2 = 4$. (Evaluate the integral by hand.)

$$S = \iint_D \sqrt{\left(\frac{\partial z}{\partial x}\right)^2 + \left(\frac{\partial z}{\partial y}\right)^2 + 1} dA$$

$$\frac{\partial z}{\partial x} = x, \quad \frac{\partial z}{\partial y} = y$$

$$S = \iint_D \sqrt{x^2 + y^2 + 1} dA$$

Use Polar Coordinates.

$$S = \iint_D \sqrt{r^2 + 1} r dr d\theta$$

Use $u = r^2 + 1$ and $du = 2r dr$

$$S = \iint_D \frac{\sqrt{u}}{2} du d\theta = \frac{1}{3} u^{3/2} \int_{\theta} d\theta = \frac{1}{3} (r^2 + 1)^{3/2} \Big|_0^2 \int_0^{2\pi} d\theta$$

(The upper bound for r is 2 because $r^2 = 4$ from the cylinder)

$$S = \boxed{\frac{1}{3}(\sqrt{125} - 1) \cdot 2\pi}$$

6. Set up the triple integral of the function $f(x, y)$ using spherical coordinate over the solid shown below.

$$f(x, y) = \frac{x^2 + y^2}{z^2}$$

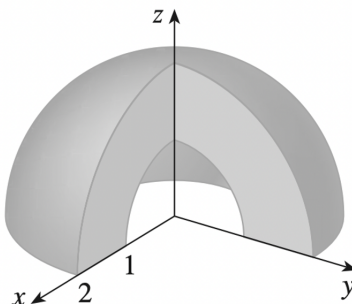

The bounds of the solid are shown below:

$$\rho : 1 \leq \rho \leq 2$$

$$\theta : \frac{\pi}{2} \leq \theta \leq 2\pi$$

$$\phi : 0 \leq \phi \leq \frac{\pi}{2}$$

Convert $f(x, y, z)$ into $f(\rho, \theta, \phi)$

$$\frac{x^2 + y^2}{z^2} = \frac{(\rho \sin \phi \cos \theta)^2 + (\rho \sin \phi \sin \theta)^2}{(\rho \cos \phi)^2} = \tan^2 \phi$$

$$\iiint_E f(x, y, z) dV = \int_0^{\pi/2} \int_{\pi/2}^{2\pi} \int_1^2 (\tan^2 \phi) (\rho^2 \sin \phi) d\rho d\theta d\phi$$

7. Using cylindrical coordinate to set up the integral to calculate the mass of a solid that is enclosed by both the cone $z = \sqrt{x^2 + y^2}$ and the sphere $x^2 + y^2 + z^2 = 8$. The density of the solid is modeled by $f(x, y, z) = \arctan(y/x)$.

Use cylindrical coordinates to represent z as a function of r .

From the cone equation: $z = \sqrt{r^2} = r$

From the sphere equation: $z^2 = 8 - (x^2 + y^2) = 8 - r^2 \rightarrow z = \sqrt{8 - r^2}$

Therefore, $r \leq z \leq \sqrt{8 - r^2}$

θ spans the entire xy -plane, so $0 \leq \theta \leq 2\pi$

To solve for the bounds of r , equate the cone and sphere equations.

$r = \sqrt{8 - r^2} \rightarrow 8 - r^2 = r^2 \rightarrow r^2 = 4 \rightarrow r = 2$ (Note that there is no negative radius, so -2 is omitted.)

The function becomes $\arctan(y/x) = \arctan(\tan \theta) = \theta$

$$\int_0^2 \int_0^{2\pi} \int_r^{\sqrt{8-r^2}} \theta r dz d\theta dr$$

8. Evaluate $\iint_R 6x - 3y dA$ where R is the parallelogram with vertices $(2, 0)$, $(5, 3)$, $(6, 7)$, and $(3, 4)$ using the transformation $x = \frac{v-u}{3}$ and $y = \frac{4v-u}{3}$.

Plot the vertices in the xy -plane in the uv -plane using the transformation equations. First by rearranging the equation into $u = f(x, y)$ and $v = f(x, y)$

$$3x = v - u, \quad 3y = 4v - u$$

Combining the two equations to eliminate u , $3x - 3y = -3v$

$$v = y - x, \text{ plug this back into } 3x = v - u$$

$$3x = y - x - u \rightarrow u = y - 4x$$

Plugging in the x, y coordinates to $u = y - 4x$, $v = y - x$

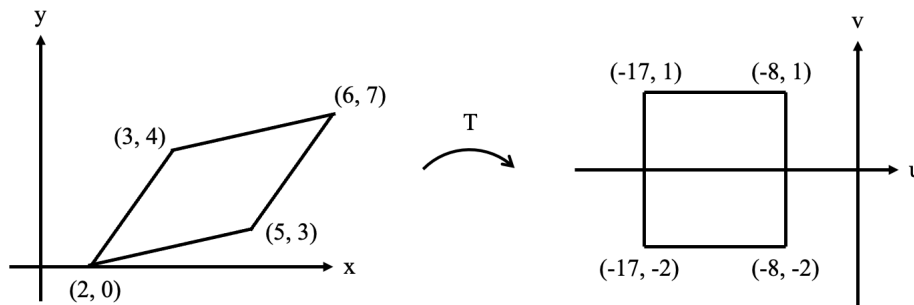

The bounds of u, v are then $-17 \leq u \leq -8$, $-2 \leq v \leq 1$. Convert the function $6x - 3y$ into $f(u, v)$:

$$f(u, v) = 6\left(\frac{v-u}{3}\right) - 3\left(\frac{4v-u}{3}\right) = -2v - u$$

Then, we calculate the absolute value of the Jacobian:

$$\begin{vmatrix} \frac{\partial x}{\partial u} & \frac{\partial x}{\partial v} \\ \frac{\partial y}{\partial u} & \frac{\partial y}{\partial v} \end{vmatrix} = \begin{vmatrix} -\frac{1}{3} & \frac{1}{3} \\ -\frac{1}{3} & \frac{4}{3} \end{vmatrix} = \frac{1}{3}$$

$$\iint_R 6x - 3y dA = \frac{1}{3} \int_{-17}^{-8} \int_{-2}^1 (-2v - u) dv du = \frac{1}{3} \int_{-17}^{-8} (3 - 3u) du = \boxed{\frac{243}{2}}$$

9. Consider the following vector fields $\vec{F}(x, y, z)$. Are they conservative? If so, find a function $f(x, y, z)$ so that $\nabla f = \vec{F}$. If not, justify your response.

(a) $\vec{F}(x, y, z) = \langle yz, xz, xy + 2z \rangle$

(b) $\vec{F}(x, y, z) = \langle y + e^x, x - \cos y, 4 + z \rangle$

(c) $\vec{F}(x, y, z) = \langle y, z^2, x \rangle$

Conservative vector field test: a vector field \vec{F} is conservative if the curl is the zero vector.

$$\vec{\nabla} \times \vec{F} = \begin{vmatrix} \hat{x} & \hat{y} & \hat{z} \\ \frac{\partial}{\partial x} & \frac{\partial}{\partial y} & \frac{\partial}{\partial z} \\ F_x & F_y & F_z \end{vmatrix} = \left\langle \frac{\partial F_z}{\partial y} - \frac{\partial F_y}{\partial z}, \frac{\partial F_x}{\partial z} - \frac{\partial F_z}{\partial x}, \frac{\partial F_x}{\partial y} - \frac{\partial F_y}{\partial x} \right\rangle = \vec{0}$$

(a)

$$\begin{vmatrix} \hat{x} & \hat{y} & \hat{z} \\ \frac{\partial}{\partial x} & \frac{\partial}{\partial y} & \frac{\partial}{\partial z} \\ yz & xz & xy + 2z \end{vmatrix} = \langle x - x, y - y, z - z \rangle = \vec{0}$$

The vector field is conservative, therefore, a potential function exists. To find it, we must find the necessary terms from each component (We neglect the constant for now, we'll add it back later).

$$\int F_x \, dx = \int yz \, dx = xyz$$

$$\int F_y \, dy = \int xz \, dy = xyz$$

$$\int F_z \, dz = \int xy + 2z \, dz = xyz + z^2$$

We see that the necessary terms are xyz and z^2 , therefore

The field is conservative and has potential function $f(x, y, z) = xyz + z^2 + C$

(b)

$$\begin{vmatrix} \hat{x} & \hat{y} & \hat{z} \\ \frac{\partial}{\partial x} & \frac{\partial}{\partial y} & \frac{\partial}{\partial z} \\ y + e^x & x - \cos y & 4 + z \end{vmatrix} = \langle 0 - 0, 0 - 0, 1 - 1 \rangle = \vec{0}$$

The vector field is conservative, therefore, a potential function exists. To find it, we must integrate each component (We neglect the constant for now, we'll add it back later).

$$\int F_x \, dx = \int y + e^x \, dx = xy + e^x$$

$$\int F_y \, dy = \int x - \cos y \, dy = xy - \sin y$$

$$\int F_z \, dz = \int 4 + z \, dz = 4z + \frac{1}{2}z^2$$

We see that the necessary terms are xy , e^x , $-\sin y$, $4z$, and $\frac{1}{2}z^2$, therefore:

The field is conservative and has potential function $f(x, y, z) = xy + e^x - \sin y + 4z + \frac{1}{2}z^2 + C$

(c)

$$\begin{vmatrix} \hat{x} & \hat{y} & \hat{z} \\ \frac{\partial}{\partial x} & \frac{\partial}{\partial y} & \frac{\partial}{\partial z} \\ y & z^2 & x \end{vmatrix} = \langle -2z, -1, -1 \rangle$$

This vector field is not conservative. Therefore, a potential function does not exist.

10. The vector field $\vec{F} = \langle 2xy + 2x + y^2, 2xy + 2y + x^2 \rangle$ is conservative. Find a potential function f for \vec{F} (a function with $\nabla f = \vec{F}$)

$$\vec{F} = \langle f_x, f_y \rangle = \langle 2xy + 2x + y^2, 2xy + 2y + x^2 \rangle$$

$$\int f_x = yx^2 + x^2 + xy^2 + C(y)$$

$$\int f_y = xy^2 + y^2 + yx^2 + C(x)$$

Looking at all the terms and comparing with \vec{F} , we know that $C(y) = y^2$ and $C(x) = x^2$, therefore the potential function is:

$$f(x, y, z) = yx^2 + x^2 + xy^2 + y^2$$

11. A particle moves along the upper part of an ellipse in the xy -plane that has its center at the origin with semi-major and semi-minor axes $a = 4$ and $b = 3$, respectively. Starting at $(a, 0, 0)$ and ending at $(-a, 0, 0)$ and subject to the following force field, what is the total work done?

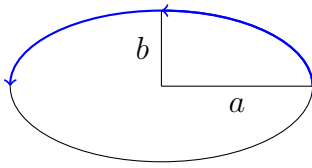

$$\vec{F} = (3x - 4y + 2z)\hat{i} + (4x + 2y - 3z^2)\hat{j} + (2xz - 4y^2 + z^3)\hat{k}$$

- (1) Find the parameterization of the ellipse

$$x = 4 \cos t, \quad y = 3 \sin t, \quad z = 0$$

$$dx = -4 \sin t \, dt, \quad dy = 3 \cos t \, dt, \quad dz = 0$$

Recall that $d\vec{r} = dx\hat{i} + dy\hat{j} + dz\hat{k}$

- (2) Take the dot product in the line integral for work. (The z component is zero so it can be ignored here).

$$\begin{aligned} \oint \vec{F} \cdot d\vec{r} &= \int [(3x - 4y)\hat{i} + (4x + 2y)\hat{j}] \cdot (dx\hat{i} + dy\hat{j}) \\ &= \oint (3x - 4y)dx + (4x + 2y)dy \end{aligned}$$

- (3) Substitute in the parameterization found in (1)

$$\oint (12 \cos(t) - 12 \sin(t))(-4 \sin(t))dt + (16 \cos(t) + 6 \sin(t))(3 \cos(t))dt$$

- (4) Determine the times that the particle is at its starting and ending position, which in this case is $0 < t < \pi$. And solve the integral

$$\int_{t=0}^{t=\pi} [(12 \cos t - 12 \sin t)(-4 \sin t) + (16 \cos t + 6 \sin t)(3 \cos t)] dt$$

$$\boxed{48\pi}$$

12. Find the work done by the force field below in moving an object from (1,1) to (2,4) (HINT: Check if the vector field is conservative).

$$\vec{F}(x, y) = \langle 6y^{\frac{3}{2}}, 9x\sqrt{y} \rangle$$

First we need to check if this vector field is conservative

$$\frac{\partial P}{\partial y} = 9\sqrt{y} \text{ and } \frac{\partial Q}{\partial x} = 9\sqrt{y}$$

Since $\frac{\partial P}{\partial y} = \frac{\partial Q}{\partial x}$ we can say the vector field is conservative

Now we can find a function $f(x, y)$ such that $\nabla f = \vec{F}$

$$\int F_x dx = \int 6y^{\frac{3}{2}} dx = 6xy^{\frac{3}{2}}$$

$$\int F_y dy = \int 9x\sqrt{y} dy = 6xy^{\frac{3}{2}}$$

Thus our potential function is

$$f(x, y) = 6xy^{\frac{3}{2}} + C$$

Now that we have a potential function we can use the Fundamental Theorem of Line Integrals to compute the work done in moving from (1,1) to (2,4)

$$\begin{aligned} W &= \int_C \vec{F} \cdot d\vec{r} = \int_C \nabla f d\vec{r} = f(x_2, y_2) - f(x_1, y_1) = \\ &f(2, 4) - f(1, 1) = (96 + C) - (6 + C) \end{aligned}$$

$$W = 90 \text{ (units)}$$

13. Evaluate $\int_C F \cdot dr$ where $F(x, y) = \langle 3y^2 - \cos y, x \sin y \rangle$ and C is a clockwise path shown below.

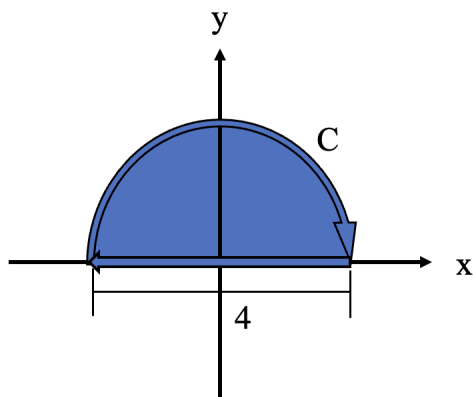

Green's Theorem states that $\int_C F \cdot dr = \oint_{-C} Pdx + Qdy = - \iint_D \frac{\partial Q}{\partial x} - \frac{\partial P}{\partial y} dA$
 (It is $-C$ because the circle is oriented in a clockwise direction.)

$$Q = x \sin y, P = 3y^2 - \cos y$$

$$- \iint_D \frac{\partial Q}{\partial x} - \frac{\partial P}{\partial y} dA = - \iint_D \sin y - (6y + \sin y) dA = \iint_D 6y dA$$

Use polar coordinates:

$$\int_0^\pi \int_0^2 (6r \sin \theta) r dr d\theta = \int_0^\pi 16 \sin \theta d\theta = 16[\cos(0) - \cos(\pi)] = \boxed{32}$$

14. The graph below shows two vector fields. Answer the following questions for each of them.
- (1) Is it a conservative vector field?
 - (2) Does it have a positive, negative, or zero curl?
 - (3) Does it have a positive, negative, or zero divergence?

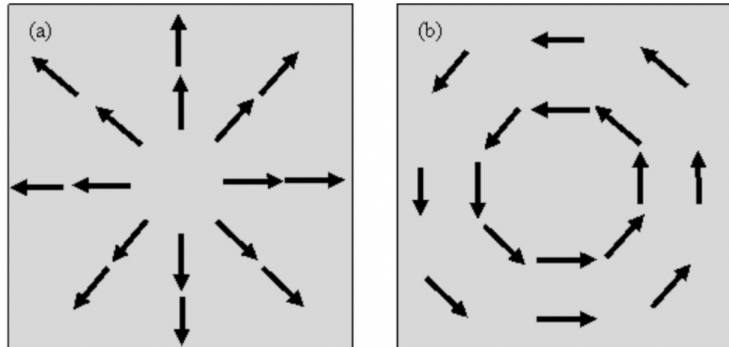

For vector field (a): (1) It is a conservative vector field because the line integral along any closed path is 0. (2) It has a zero curl because the vectors are not rotating. (3) It has a positive divergence because the vectors have the tendency to diverge out from a point.

For vector field (b): (1) It is not a conservative vector field because the line integral along the closed path is nonzero. (2) It has a positive curl as vectors are rotating in the counterclockwise direction. (3) It has a zero divergence because the vectors are not diverging from a single point.

15. Evaluate $\int_C \nabla f \cdot d\vec{r}$ where $f(x, y) = ye^{x^2-1} + 4x\sqrt{y}$ and C is given by $\vec{r}(t) = \langle 1 - t, 2t^2 - 2t \rangle$ with $0 \leq t \leq 2$.

Use the fundamental theorem of line integral.

$$\int_C \nabla f \cdot d\vec{r} = f[\vec{r}(2)] - f[\vec{r}(0)]$$

$$\vec{r}(0) = \langle 1, 0 \rangle, \text{ and } \vec{r}(2) = \langle -1, 4 \rangle$$

$$f[\vec{r}(2)] - f[\vec{r}(0)] = f(-1, 4) - f(1, 0) = -4 - 0 = \boxed{-4}$$