



## Center for Academic Resources in Engineering (CARE) Peer Exam Review Session

Phys 212 – University Physics: Electricity and Magnetism

### Midterm 2 Worksheet Solutions

---

*The problems in this review are designed to help prepare you for your upcoming exam. Questions pertain to material covered in the course and are intended to reflect the topics likely to appear in the exam. Keep in mind that this worksheet was created by CARE tutors, and while it is thorough, it is not comprehensive. In addition to exam review sessions, CARE also hosts regularly scheduled tutoring hours.*

---

Tutors are available to answer questions, review problems, and help you feel prepared for your exam during these times:

Session 1: Wed, Oct. 30th, 7-8:30 pm Aaron, Aarnav, Krish

Session 2: Thur, Oct. 31th, 6-7:30 pm Ray, Johan, Jacob

Can't make it to a session? Here's our schedule by course:

<https://care.grainger.illinois.edu/tutoring/schedule-by-subject>

Solutions will be available on our website after the last review session that we host.

Step-by-step login for exam review session:

1. Log into Queue @ Illinois: <https://queue.illinois.edu/q/queue/848>
2. Click “New Question”
3. Add your NetID and Name
4. Press “Add to Queue”

**Please be sure to follow the above steps to add yourself to the Queue.**

Good luck with your exam!

1. An electron of mass  $m$  and charge  $q$  is put in a track and accelerated to the right (in the plane of the paper) from rest through a potential difference  $V$ . The electron then enters a region containing a uniform magnetic field, and makes a  $180^\circ$  turn in the field to enter a track that is parallel to its initial trajectory. Suppose the system is 2D lying on the ground.

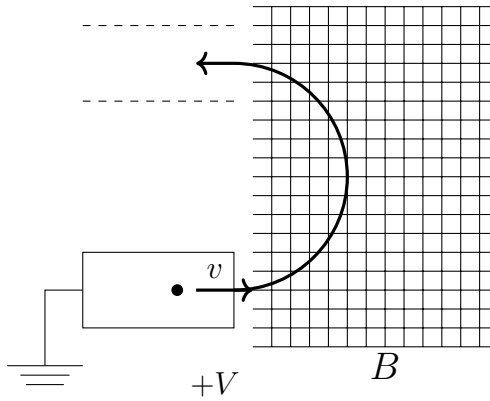

$$V = 300 \text{ V}$$

$$B = 0.2 \text{ T}$$

$$q = -1.6 \times 10^{-19} \text{ C}$$

$$m = 9.11 \times 10^{-31} \text{ kg}$$

- (i) In order to enter the destination track what is the direction of the magnetic field?  
 (ii) What is the speed of the electron?  
 (iii) What is the radius of the path?  
 (iv) How much time is spent in the magnetic field?
- (i) We will use the Lorentz Force equation, noting that at the point of entry, the force must be upward (since it must point radially inward)

$$\vec{F} = q\vec{v} \times \vec{B}$$

Start with your right hand (right hand rule) in the direction of the particle's motion, curl it in the direction necessary to make  $\vec{F}$  point upward. This means  $\vec{B}$  is into the page.

However, since we are dealing with a negative charge the sign of the B-field should be in the opposite direction.

The B-field is out of the page

- (ii) We can use the fact that  $|W| = |qV|$  and the work-kinetic energy theorem to find the total kinetic energy of the particle after it has accelerated through  $V$ .

$$qV = \frac{1}{2}mv^2$$

$$v = 10.3 \times 10^6 \text{ m/s}$$

- (iii) Equate the Lorentz force (magnetic force) with the centripetal force to get

$$R = \frac{mv}{qB} = 2.92 \times 10^{-4} \text{ m}$$

Note that the cross product becomes  $qvB$  because  $\sin(\theta)$  is 1 while  $\vec{v}$  and  $\vec{B}$  are perpendicular.

- (iv) We use the relation between speed ( $v$ ), time ( $t$ ), and distance ( $D$ )  $t = \frac{D}{v}$ , using the circular arc length as  $D$  (Here  $D$  is  $\pi R$  since it's half the circumference of a circle).

$$t = \pi \frac{R}{v} = \boxed{8.68 \times 10^{-11} \text{ s}}$$

2. Six resistors are connected to a 15 V battery as shown in the figure  $R_1 = 100 \Omega$ ,  $R_2 = 70 \Omega$ ,  $R_3 = 50 \Omega$ ,  $R_4 = 10 \Omega$ ,  $R_5 = 30 \Omega$  and  $R_6 = 20 \Omega$ .

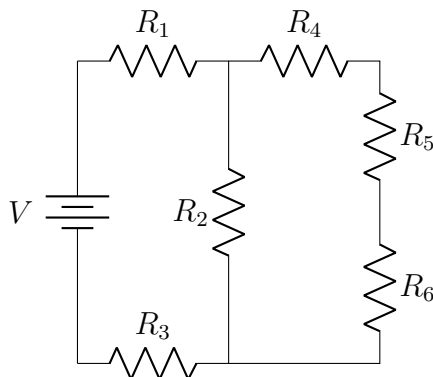

- (i) Are  $R_1$  and  $R_2$  in series, parallel, both or neither?  
 (ii) What is the equivalent resistance of the circuit?  
 (iii) What is the voltage across  $R_2$ ?  
 (iv) Say  $R_2$  was replaced with a bare wire, what would be the voltage of  $R_3$
- (i) Neither; a loop through one does not necessarily go through the other (there are multiple paths), nor can a single loop be drawn around only those two elements.  
 (ii) Resistors in series add directly, resistors in parallel add like such

$$\frac{1}{R_{ab}} = \frac{1}{R_a} + \frac{1}{R_b}$$

$$R_{456} = 10 + 30 + 20 = 60$$

$$R_{2456} = \left( \frac{1}{60} + \frac{1}{70} \right)^{-1} = 32.31$$

$$R_{123456} = 32.21 + 100 + 50 = \boxed{182.31 \Omega}$$

- (iii) Using the previous question, we can solve for the current through the battery using

$$I_{\text{battery}} = \frac{V}{R_{123456}} = 0.0823 \text{ A}$$

Note that  $I_{\text{battery}}$  is also the current through  $R_1$  and  $R_3$  because of the junction rule. Let  $I_1$  be the current through  $R_2$ . We can now set up a KVL equation on the left loop:

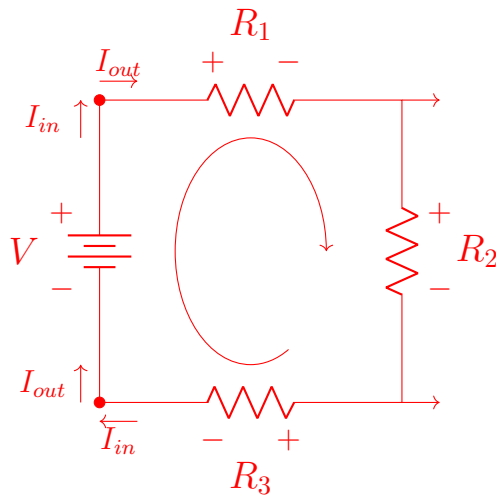

$$-15 + R_1 I_{battery} + R_2 I_1 + R_3 I_{battery} = 0$$

$$I_1 = 0.03793 \text{ A}$$

From Problem (ii) we know:

$$V_{2456} = I_{battery} R_{2456}$$

$$V_{2456} = 2.66 \text{ V}$$

We also know from Problem (ii):

$$V_2 = V_{456} = 2.66 \text{ V}$$

$$V_{R_2} = 2.66 \text{ Volts}$$

- (iv) Current would not flow through resistors  $R_4$ ,  $R_5$  and  $R_6$  because all the current would move through the bare wire. Therefore the voltage of  $R_3$  can be described as:

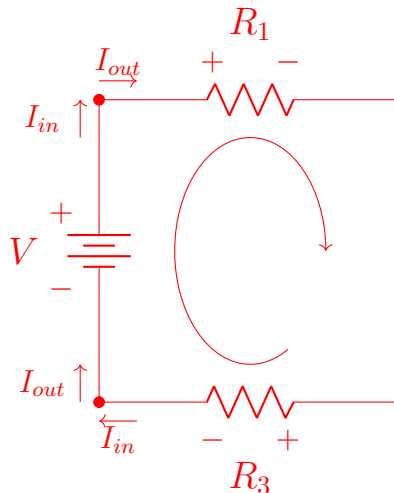

Using a KVL equation, we find that the new current through  $R_3$  is

$$-15 + R_1 I_{\text{battery}} + R_3 I_{\text{battery}} = 0$$

$$I_{\text{battery}} = 0.1 \text{ A}$$

Then using Ohm's Law

$$V_{R_3} = 5 \text{ Volts}$$

3. Two resistors of equal resistance ( $R = 20 \Omega$ ) are connected to a capacitor ( $C = 40 \mu F$ ) and a battery ( $V = 5 \text{ V}$ ) as in the figure. In the beginning the switch is open from both positions, a and b, and the capacitor is uncharged.

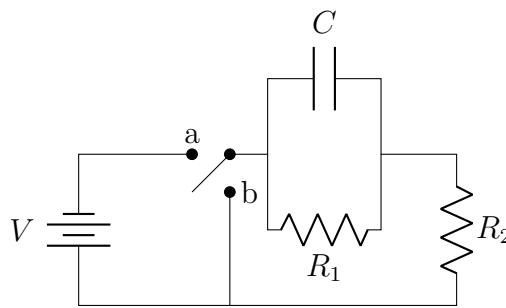

- What is the current through the capacitor immediately after the switch is moved to position a?
- Calculate the charge on the capacitor after the switch has been in position a for a long time.
- After the capacitor was fully charged, the switch is moved to position b, discharging the capacitor. What is the time constant of discharging the capacitor?

- Create a KVL loop that includes the battery, capacitor, and resistor  $R_2$ .

$$-V + V_c + I_c R = 0$$

Immediately after the switch is closed the capacitor acts as a bare wire, therefore:

$$V_c \text{ (immediately after)} = V_c \text{ (before)} = 0 \text{ Volts}$$

Only one of the resistors experiences a current ( $R_2$ ) since the capacitor is a "bare wire" at first.

$$V = I_c R$$

$$I_c = 0.25 \text{ A}$$

- After a long time, the capacitor is fully charged and has a voltage equal to  $R_1$  (KVL). The current through  $R_1$  after a long time is found by

$$V = I_\infty (R_1 + R_2)$$

$$I_\infty = 0.125 \text{ A}$$

Therefore, the voltage across  $R_1$  is  $V_R = 0.125 * 20 = 2.5$  V

This voltage is equal to the voltage across the capacitor because they are in parallel, so we can use  $Q = VC$  to find

$$Q = CV_R = \boxed{100 \mu\text{C}}$$

- (iii) The time constant is found by  $\tau = R_{12}C$ . Since the two resistors are in parallel, we can calculate  $R_{12}$  using

$$R_{12} = \left( \frac{1}{R_1} + \frac{1}{R_2} \right)^{-1} = 10$$

$$\tau = R_{12}C = \boxed{400 \mu\text{s}}$$

4. Three squares of current-carrying wire are centered at the origin with each side of length  $2a$ , as shown, with  $a = 0.17$  m. There is a current  $I$  going through each in the counter-clockwise direction as seen looking down the  $z$ -axis. A uniform magnetic field with  $B = 0.12$  T points along the  $y$ -axis. The magnitude of the total magnetic moment (for the three loops together) is  $\mu = 4.5$  Tm<sup>2</sup>.

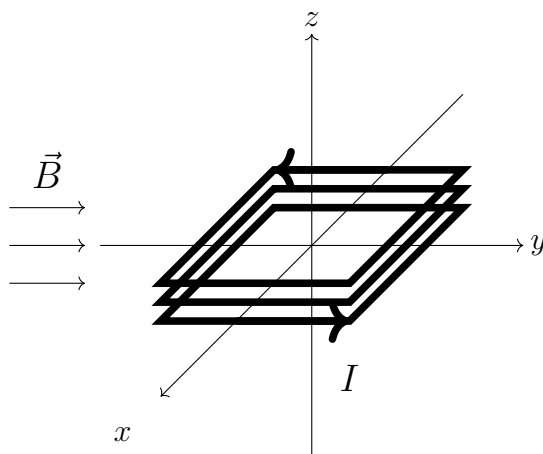

- (i) What is the magnitude of the current  $I$ ?  
 (ii) What is the direction of the torque on the loop?

- (i) Since this is a square, the area vector has magnitude  $|A| = 4a^2$ .

$$\mu = NIA$$

$$4.5 = 3I(4a^2)$$

$$\boxed{I = 12.976 \text{ A}}$$

- (ii)

$$\vec{\tau} = \vec{\mu} \times \vec{B}$$

Using right hand rule, curl your hand in the direction of current to find that  $\vec{\mu}$  points along  $+\hat{z}$ . Now do  $\vec{\mu} \times \vec{B}$  by first pointing your hand in the direction of  $\vec{\mu}$  and curling towards the direction of  $\vec{B}$ . This gives your thumb in the direction of  $-\hat{x}$

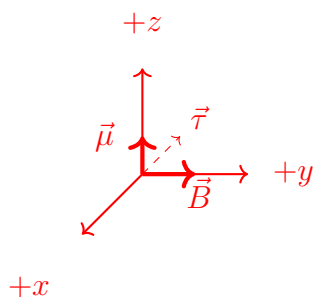

The direction of  $\vec{\tau}$  is  $-\hat{x}$

5. A wire loop with mass  $m = 0.4$  kg, width  $w = 1.5$  m and height  $h = 0.8$  m is released from rest just above a region of uniform magnetic field  $B = 2.5$  T directed into the page. There is no magnetic field outside this region. The gravitational force causes the loop to fall and its motion is constrained to the  $xy$ -plane (e.g. it falls straight down without rotating). At the moment shown it is observed to be moving downward with speed  $|v| = 1.2$  m/s, and the magnitude of the current induced in the loop is measured to be  $I = 0.74$  Amps.

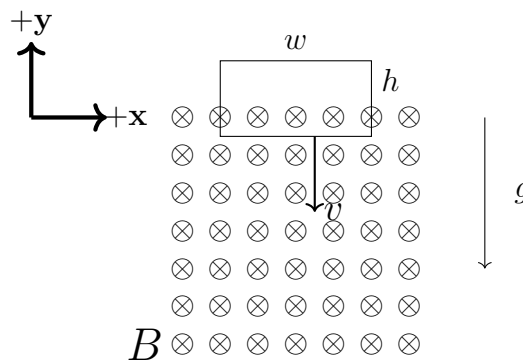

- (i) What is the resistance of the loop?
- (ii) At the position shown in the figure the induced current in the loop is flowing clockwise or counterclockwise?

(i) From prelectures:

$$\mathcal{E} = vBL = vB(w) = 4.5 \text{ V}$$

Using Ohm's Law we can solve for the resistance:

$$R = \frac{V}{I} = \boxed{6.08 \text{ } \Omega}$$

**If this makes perfect sense to you great! However, if you're not satisfied with just plugging and chugging equations here is the actual derivation:**

In this question we only consider the fraction of the area that is in the magnetic field  
 We know that induced voltage can be describe by

$$\text{EMF} = -\frac{d\Phi_B}{dt}$$

Where  $\Phi$  is the measured flux,  $\Phi = BA(t) = Bwy(t)$  where  $y(t)$  is the height of the loop in the magnetic field and is described by  $y(t) = vt$

Therefore:

$$\text{EMF} = \left| \frac{d\Phi}{dt} \right| = Bw \left( \frac{dy}{dt} \right) = Bwv = 4.5 \text{ V}$$

Using Ohm's Law to find the resistance:

$$R = \frac{\text{EMF}}{I} = \boxed{6.08 \ \Omega}$$

- (ii) Using Lenz' Law, we know that the induced current will be such that the induced field opposes the changing flux. The flux is increasing into the page, therefore, we want an induced field out of the page. Using the right hand rule ( $F = qv \times B$ ), this means current must be counterclockwise.

6. A generator consists of a square loop of wire with length  $L = 1.5 \text{ m}$  spinning with constant angular velocity  $\omega$ . A uniform magnetic field  $B = 0.8 \text{ T}$  is directed in the positive y-direction as shown in the figure.

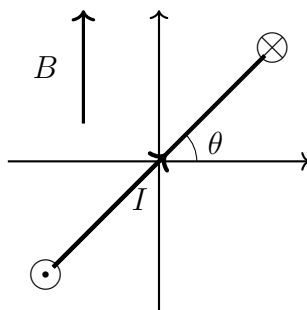

- (i) As the loop spins, at which orientation is the peak voltage generated?  
 (ii) If the peak voltage generated is 250 Volts, what is the angular velocity of the loop?

- (i) We know that peak voltage is achieved when

$$\text{EMF} = -\frac{d\Phi_B}{dt}$$

The flux as a function of time is

$$\Phi = A \cdot B = AB \cos(\omega t)$$

This is because of the fact that when  $\theta = 0$ , the flux is at its maximum, so we need a cosine function. Taking its derivative

$$\text{EMF} = -\frac{d\Phi}{dt} = AB\omega \sin(\omega t)$$

Sine reaches its maximum at  $90^\circ$ , therefore peak voltage is when the loop reaches  $90^\circ$



(ii) From the previous question, we know that:

$$EMF = -AB\omega \sin(\omega t)$$

$$EMF_{max} = 250 = AB\omega$$

$$\omega = 139 \text{ rad/sec}$$

7. A current  $I = 5 \text{ mA}$  is uniformly distributed over the above wire and pointing out of the page. The outer radius is  $b = 4 \text{ cm}$  and the inner radius is  $a = 2 \text{ cm}$ .

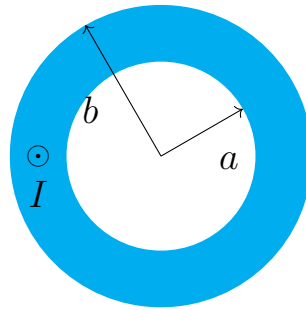

- (i) What is the current density at a point inside the wire (where positive  $z$  points out of the page)?  
 (ii) What is the magnitude of the magnetic field at radius  $r = 3 \text{ cm}$  from the central axis?

(i) The current density is given by

$$J = \frac{I}{A}$$

Where  $A$  is the cross sectional area. Therefore  $I = 5 \text{ mAmps}$  and  $A = \pi(b^2 - a^2)$

$$J = 1.33 \text{ A/m}^2$$

(ii) Ampere's Law is given by

$$\oint \vec{B} \cdot d\vec{l} = \mu_0 I_{enc}$$

Our enclosed loop would be a circle with radius  $r$ .

Using the current density found in the previous question, we can say that  $I_{enc} = J\pi(r^2 - a^2)$ .

For  $dl$ , we are using the circumference of the circle:  $2\pi r$

After solving for  $B$ :

$$B = \frac{\mu_0 J \pi (r^2 - a^2)}{2\pi r}$$

$$B = 1.38 \times 10^{-8} \text{ T}$$

8. The following questions refer to the diagram below.

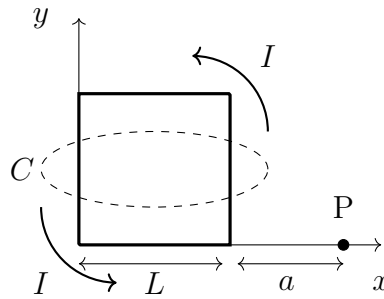

(i) Which of the following expressions computes the magnetic field at point P due only to the right vertical segment of the wire?

a)  $-\hat{z} \frac{\mu_0 I}{4\pi} \int_0^L dy \frac{a}{(a^2+y^2)^{3/2}}$

b)  $\hat{x} \frac{\mu_0 I}{4\pi} \int_0^L dy \frac{a}{(a^2+y^2)^{3/2}}$

c)  $-\hat{z} \frac{\mu_0 I}{4\pi} \int_0^L dy \frac{a}{(a^2+y^2)}$

d)  $\hat{x} \frac{\mu_0 I}{4\pi} \int_0^L dy \frac{a}{(a^2+y^2)}$

e)  $\hat{z} \frac{\mu_0 I}{4\pi} \int_0^L dy \frac{a}{(a^2+y^2)}$

(ii) What is the line integral of the B field around the loop C that goes around the square shown in the above figure?  $\oint B \cdot dl =$

a) 0

b)  $2\mu_0 I$

c)  $-2\mu_0 I$

(i) Use the Biot-Savart Law

$$d\vec{B} = \frac{\mu_0}{4\pi} \frac{I d\vec{l} \times \hat{r}}{r^2}$$

To find  $r$  you have to find the distance from point P to the infinitesimal length of wire ( $dl$ ).

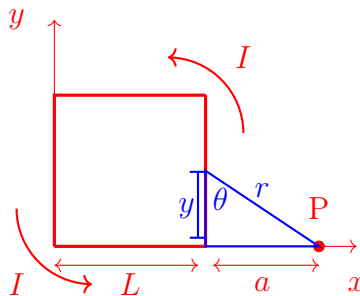

We have to define an angle  $\theta$  to relate  $dl$  and  $r$  in the cross product.

From the diagram above,  $r = \sqrt{a^2 + y^2}$  and  $d\vec{l} \times \hat{r} = dy \sin(\theta)(-\hat{z})$

Where  $\sin(\theta) = \frac{a}{\sqrt{a^2 + y^2}}$

$$\text{Thus, } \vec{B} = -\hat{z} \frac{\mu_0 I}{4\pi} \int_0^L dy \frac{a}{(a^2 + y^2)^{3/2}}$$

- (ii) The answer is A because the total current enclosed is zero, since the current going in from one side is cancelled by the current going out on the other side. The answer is **(a)**.