



Center for Academic Resources in Engineering (CARE) Peer Exam Review Session

Phys 212 – University Physics: Electricity and Magnetism

Midterm 1 Worksheet Solutions

The problems in this review are designed to help prepare you for your upcoming exam. Questions pertain to material covered in the course and are intended to reflect the topics likely to appear in the exam. Keep in mind that this worksheet was created by CARE tutors, and while it is thorough, it is not comprehensive. In addition to exam review sessions, CARE also hosts regularly scheduled tutoring hours.

Tutors are available to answer questions, review problems, and help you feel prepared for your exam during these times:

Session 1: Sept. 25, 5:30-7:30pm Arnav, Jacob, Krish

Session 2: Sept. 26, 5:30-6:30pm Johan, Aaron, Ray

Can't make it to a session? Here's our schedule by course:

<https://care.grainger.illinois.edu/tutoring/schedule-by-subject>

Solutions will be available on our website after the last review session that we host.

Step-by-step login for exam review session:

1. Log into Queue @ Illinois: <https://queue.illinois.edu/q/queue/848>
2. Click "New Question"
3. Add your NetID and Name
4. Press "Add to Queue"

Please be sure to follow the above steps to add yourself to the Queue.

Good luck with your exam!

1. A solid spherical conductor centered at the origin has radius $r = 90$ cm and carries a total positive charge $Q = 9 \mu\text{C}$

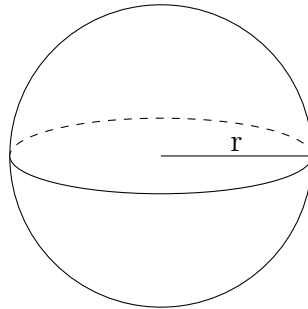

- (i) What is the magnitude of the electric field, $|E|$, at a radius of 1.7 m from the origin
- $|E| = 28000$ N/C
 - $|E| = 1.75 \times 10^5$ N/C
 - $|E| = 1 \times 10^5$ N/C
- (ii) If we define the electric potential to be zero at infinity, what is the potential V at a radius of 1.7 m from the origin? (Note: this is outside of the conducting sphere)
- $V = -47650$ Volts
 - $V = 90000$ Volts
 - $V = 47650$ Volts
 - $V = -90000$ Volts
 - $V = 0$ Volts
- (iii) If we define the electric potential V to be zero at infinity, what is the potential at a radius of 0.15 m from the origin? (Note: this is inside the conducting sphere)
- 540000 Volts
 - 540000 Volts
 - 90000 Volts
 - 90000 Volts
 - 0 Volts
- (iv) What would the answer to problem (iii) be if the sphere were an insulator instead of a conductor
- 90000 Volts
 - 90000 Volts
 - 164000 Volts
 - 164000 Volts
 - 134000 Volts
 - 134000 Volts

(i) Using Gauss' Law

$$\oint E \cdot dl = \frac{Q_{enc}}{\epsilon_0}$$

$$E(4\pi r^2) = \frac{Q}{\epsilon_0}$$

$$E = \frac{Q}{4\pi\epsilon_0 r^2}$$

Plugging in all the values we get that $|E|$ is around $\boxed{28000 \text{ N/C}}$. Note: don't forget to convert from centimeters to meters.

(ii)

$$\Delta V = - \int E \cdot dl$$

$$V(1.7) - V(\infty) = - \int_{\infty}^{1.7} \frac{Q}{4\pi\epsilon_0 r^2} dr$$

$$= - \frac{Q}{4\pi\epsilon_0} \left(- \frac{1}{r} \right)_{\infty}^{1.7}$$

$$= + \frac{Q}{4\pi\epsilon_0 r} \Big|_{\infty}^{1.7}$$

$$= \frac{Q}{4\pi\epsilon_0 * 1.7}$$

Plugging in the values we get that V is around $\boxed{47650 \text{ Volts}}$.

(iii) Since this is a conducting sphere, the electric field inside of it is zero. This means that the potential inside of it is *constant* ($\Delta V = 0$ inside the sphere). Therefore, the potential at any point in the sphere is equal to the potential at the surface of the sphere.

$$\Delta V = - \int E \cdot dl$$

$$V(0.9) - v(\infty) = - \int_{\infty}^{0.9} E_{outside} \cdot dl$$

$$= - \frac{Q}{4\pi\epsilon_0} \left(- \frac{1}{r} \right)_{\infty}^{0.9}$$

$$= + \frac{Q}{4\pi\epsilon_0 0.9}$$

Plugging in the values we get that V is around $\boxed{90000 \text{ Volts}}$.

(iv) First we have to find the expression for the E-field inside the sphere:

$$\rho = \frac{Q}{\frac{4}{3}\pi(0.9^3)} = 2.94 \times 10^{-6} \frac{\text{C}}{\text{m}^3}$$

$$\oint E \cdot dA = \frac{Q_{enc}}{\epsilon_0}$$

$$E(4\pi r^2) = \frac{\rho(\frac{4}{3}\pi r^3)}{\epsilon_0}$$

$$E_{inside} = \frac{\rho r}{3\epsilon_0} = \frac{Qr}{4\epsilon_0 R^3 \pi}$$

Where R is the radius of the sphere.

Now we can find the potential difference

$$\Delta V = - \int E \cdot dl$$

$$V(0.15) - v(\infty) = - \int_{\infty}^{0.9} E_{outside} \cdot dl - \int_{0.9}^{0.15} E_{inside} \cdot dl$$

$$= - \frac{Q}{4\pi\epsilon_0} \left(-\frac{1}{r} \right)_{\infty}^{0.9} - \frac{\rho}{6\epsilon_0} (r^2)_{0.9}^{0.15}$$

$$= + \frac{Q}{4\pi\epsilon_0(0.9)} - \frac{\rho}{6\epsilon_0} (0.15^2 - 0.9^2)$$

Plugging in the values the expression yields 134000 Volts.

2. The figure shows three infinite planes. The right two planes are insulating with uniform charge and density $\sigma = 7 \text{ C/m}^2$. The left plane is uncharged ($\sigma_L + \sigma_R = 0$) and conducting. Also shown in the figure are three Gaussian surfaces labeled S_1 , S_2 and S_3 . All three Gaussian surfaces have identical dimensions in the yz plane, but surface S_3 is 4 times as wide in the x -direction.

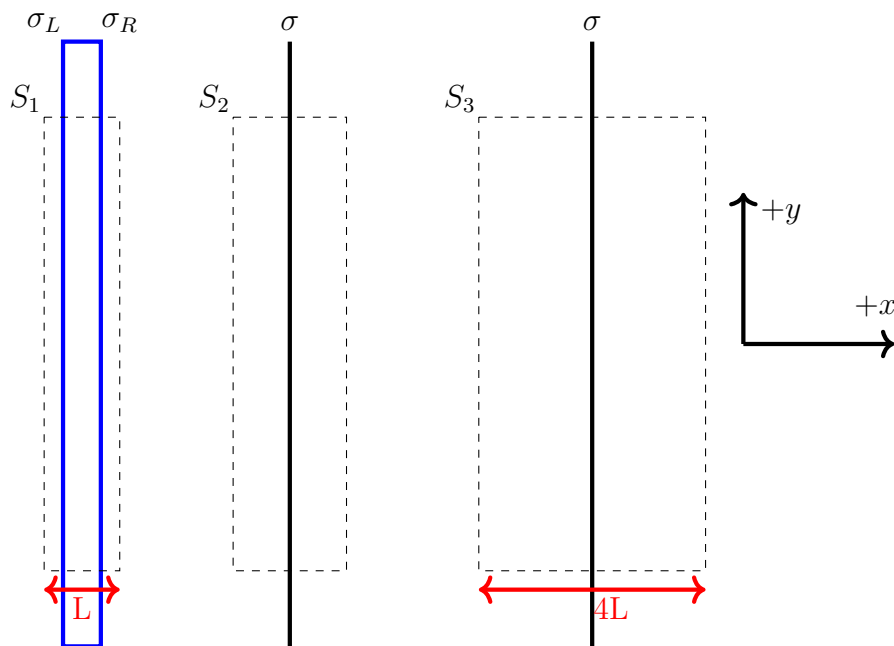

- (i) What is the induced charge on the right side of the conducting slab?
 a) $\sigma_R = -7 \text{ C/m}^2$

- b) $\sigma_R = -14 \text{ C/m}^2$
 c) $\sigma_R = -3.5 \text{ C/m}^2$

(ii) Compare the total flux through Gaussian surface S_1 with the total flux through surface S_3

- a) $\Phi_1 < \Phi_3$
 b) $\Phi_1 = \Phi_3$
 c) $\Phi_1 > \Phi_3$

(iii) Compare the total flux through Gaussian surface S_2 with the total flux through the surface S_3

- a) $\Phi_2 = \Phi_3$
 b) $\Phi_2 < \Phi_3$
 c) $\Phi_2 > \Phi_3$

(i) Treat σ_L and σ_R to be their own infinite planes

$$E = \frac{\sigma}{2\epsilon_0}$$

Inside conductor $E = 0$

$$E = 0 = \frac{1}{2\epsilon_0}(-\sigma_L + \sigma_R + \sigma + \sigma)$$

Using $\sigma_L = -\sigma_R$

$$2\sigma_R = -2\sigma$$

$$\sigma_R = -\sigma = \boxed{-7 \text{ C/m}^2}$$

(ii) The flux through S_1 is zero. This is because every field line that enters it, also exits it (and there is no net charge within S_1 for electric field lines to leave it). This is because $|\sigma_L| = |\sigma_R|$. Also all the field lines from the other planes enter and exit the surface, netting zero flux.

S_3 on the other hand has many field lines leave its right side, but zero flux out of its left side, there the flux through S_3 is greater than that of S_1 . The answer is therefore **(a)**.

(iii) The flux through S_2 and S_3 is zero at the inner edges (right edge of S_2 and left edge of S_3 respectively). Therefore, it's only the outer edges of those two surfaces that contribute to the total flux, and those two contributions are equal since they have the same magnitude of electric fields passing through them. The answer is **(a)**.

3. A solid, infinite metal cylinder of radius $a = 2 \text{ cm}$ is centered on the origin, and has charge density $\lambda_{inner} = -10 \text{ nC/cm}$. Surrounding this cylinder is a cylindrical metal shell of inner radius $b = 5 \text{ cm}$ and outer radius $c = 7.5 \text{ cm}$. This shell is also centered on the origin, and has total charge density $\lambda_{shell} = +5 \text{ nC/cm}$.

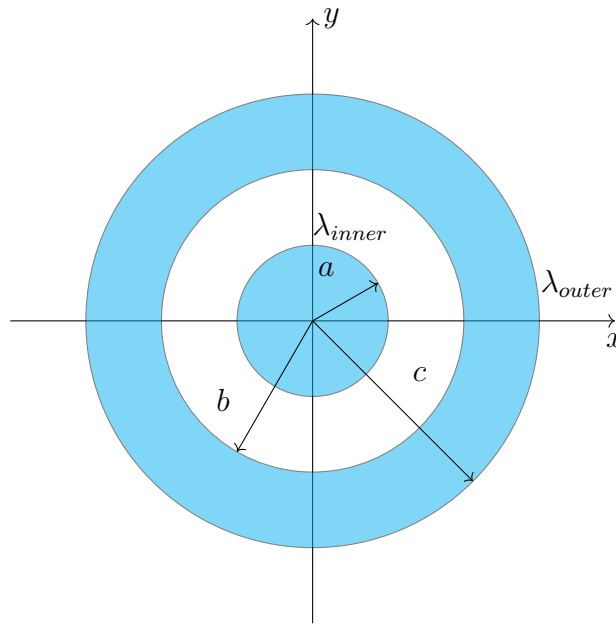

- (i) Find the potential difference $V_a - V_c$ between the surface of metal cylinder ($r = a$) and the outer surface of the metal shell ($r = c$).
 - a) -16.5 kV
 - b) -8.7 kV
 - c) 0 kV
 - d) 8.7 kV
 - e) 16.5 kV

- (ii) What is the linear charge density, $\lambda_{shell-outer}$, on the outer surface of the cylinder shell?
 - a) 5 nC/cm
 - b) 3 nC/cm
 - c) -3 nC/cm
 - d) 0 nC/cm
 - e) -5 nC/cm

- (iii) If the inner cylinder is connected to ground, the charge density on the inner surface of the outer shell will
 - a) Remain unchanged
 - b) Decrease in magnitude
 - c) Increase in magnitude
 - d) Be zero

- (iv) Assume that the metal cylinder in the center is now switched to an insulating cylinder with the same charge density λ and radius a . What is its volume charge density, ρ ?
 - a) 0
 - b) -0.80 nC/cm^3

- c) -4.44 nC/cm^3
- d) $.80 \text{ nC/cm}^3$
- e) 4.44 nC/cm^3

- (i) The potential difference between a and c is the same as the potential difference between a and b because the electric field inside the conductor is zero. Therefore, to solve the problem all we need is

$$\Delta V = - \int_a^b E \cdot dl$$

We know that

$$\begin{aligned} \oint E \cdot dA &= \frac{q_{enc}}{\epsilon_0} \\ q_{enc} &= \lambda_{inner} * L \\ E(2\pi r L) &= \frac{\lambda_{inner} L}{\epsilon_0} \\ E &= \frac{\lambda_{inner}}{2\pi\epsilon_0 r} \end{aligned}$$

from the electric field equation outside of a cylinder. Putting all of the values into the integral gives an answer of $\boxed{-16.5 \text{ kV}}$ (be careful with units, nC and cm).

- (ii) Using Gauss' Law we draw a Gaussian surface through the conductor. Since the E-field has to be 0 along the surface

$$0 = \lambda_{inner} + \lambda_{shell-inner}$$

This means that the inner shell has a charge density of 10 nC/cm . Now to get the outer charge density we know that

$$5 \text{ nC/cm} = \lambda_{inner} + \lambda_{shell-inner}$$

which gives us an answer of $\boxed{-5 \text{ nC/cm}}$.

- (iii) When the inner cylinder is connected to ground, it has a net charge of zero, so drawing a Gaussian surface through the outer cylinder has to be 0 as well to get an E-field of 0 along the Gaussian surface. Therefore, the charge density of the inner surface of the outer shell becomes 0. The answer is **(d)**.
- (iv) Let's focus on one section of the charged insulating cylinder with a length L .

$$\begin{aligned} Q &= \lambda_{inner} * L \\ \rho &= \frac{Q}{V} = \frac{\lambda_{inner} * L}{(\pi a^2 L)} = \frac{\lambda_{inner}}{(\pi a^2)} \end{aligned}$$

This gives an answer of $\boxed{-0.8 \text{ nC/cm}^3}$

4. The circuit below contains 3 capacitors, all of initial value $C = 4 \mu\text{F}$. The voltage source is 10 V .

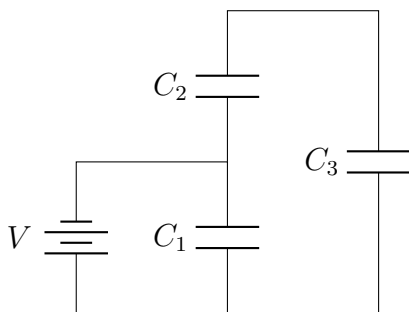

- (i) What is the charge on the capacitor C_1 ?
- $18.3 \mu\text{C}$
 - $21.4 \mu\text{C}$
 - $40.0 \mu\text{C}$
 - $0 \mu\text{C}$
 - $12.0 \mu\text{C}$
- (ii) What is the charge on the capacitor C_2 ?
- $20.0 \mu\text{C}$
 - $19.3 \mu\text{C}$
 - $7.9 \mu\text{C}$
 - $25.6 \mu\text{C}$
 - $25.0 \mu\text{C}$
- (iii) Now suppose C_3 is removed and C_2 is modified by filling it with a dielectric material with constant $\kappa = 5$. How does the charge Q_2 change?
- Q_2 decreases
 - Q_2 stays the same
 - Q_2 increases
- (iv) Now add C_3 back while the dielectric with constant $\kappa = 5$ is kept in C_2 . How does the charge Q_3 change from when there was no dielectric?
- Q_3 decreases because the capacitance of C_3 decreases relative to that of C_2
 - Q_3 stays the same because the charge of capacitors in series is the same
 - Q_3 increases because the capacitance of C_2 increases
- (v) How does the charge on C_1 change when C_2 is modified by filling it with a dielectric with constant $\kappa = 5$?
- Q_1 decreases because the capacitance of C_1 decreases relative to that of C_2
 - Q_1 stays the same because the voltage across C_1 is the same as it was originally
 - Q_1 increases because the effective capacitance of C_2 and C_3 part of the circuit increases

- (i) Based on the circuit schematic, we can see that the battery and C_1 are in parallel (since a loop can be drawn only including those two elements). This means that the voltage across C_1 must be V using KVL (loop drawn below). We then use the capacitor equation, $Q = CV$.

$$V = 10 \text{ Volts}$$

$$Q = CV = 4 * 10 = \boxed{40 \mu\text{C}}$$

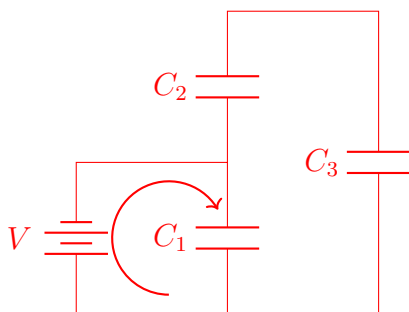

- (ii) Capacitor 2 and 3 are in series, so combine capacitors 2 and 3 in series using the equation

$$\frac{1}{C_{2,3}} = \frac{1}{C_2} + \frac{1}{C_3}$$

This gives that $C_{2,3} = 2 \mu\text{F}$

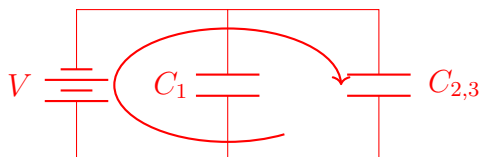

$C_{2,3}$ is in parallel with the voltage source, thus the voltage across $C_{2,3}$ is V using KVL (shown above).

$$Q_{2,3} = C_{2,3}V = 2 * 10 = 20 \mu\text{C}$$

$$Q_2 = Q_3 = Q_{2,3}$$

Therefore $Q_2 = \boxed{20 \mu\text{C}}$

- (iii)

$$C = \frac{\kappa\epsilon_0 A}{d} = \frac{Q}{V}$$

From the equations above, we can see that adding a dielectric into the capacitor we increase the capacitance. This means that either the charge on it must increase or the voltage must decrease and since we have a constant voltage source in parallel with C_2 , we know that the charge must increase. The answer is (c).

- (iv) Recall that capacitors in series can be combined using either of the following equations:

$$\frac{1}{C_{2,3}} = \frac{1}{C_2} + \frac{1}{C_3}$$

$$C_{2,3} = \left(\frac{1}{C_2} + \frac{1}{C_3}\right)^{-1} = \frac{C_2 \times C_3}{C_2 + C_3}$$

Therefore, the new capacitance with the dielectric in capacitor 2 will be

$$C'_{2,3} = \frac{20 \times 4}{20 + 4} = \frac{80}{24} = \frac{10}{3}$$

Since the voltage across the two capacitors is the same (the battery voltage), an increase in capacitance must increase the charge on both the capacitors as they have the same charge.

The answer is **(c)**.

- (v) The charge C_1 does not depend on any other capacitors **not** in series with it. The fact that it's connected to the battery forces its voltage (and therefore charge) to stay constant in this case. The answer is **(b)**.