

Civil Engineering Undergraduate Handbook 2024-2025

THE GRAINGER COLLEGE OF ENGINEERING



EDUCATION RESEARCH ENGAGEMENT IMPACT EDUCATION RESEARCH ENGAGEMENT IMPACT EDUCATION RESEARCH ENGAGEMENT IMPACT



UNIVERSITY OF
ILLINOIS
URBANA-CHAMPAIGN

Table of Contents

Table of Contents	i
1 Introduction	1
1.1 CEE Undergraduate Program Mission and Program Educational Objectives.....	1
1.2 Department of Civil and Environmental Engineering – An Overview.....	2
1.3 The Department of Civil and Environmental Engineering.....	3
1.4 Department of Civil and Environmental Undergraduate Program.....	3
1.5 Grainger College of Engineering.....	5
1.6 James Scholar Honors Program.....	5
1.7 Center for Academic Resources (CARE).....	6
1.8 Engineering Career Services.....	6
1.9 International Programs in Engineering (IPENG).....	6
1.10 Academics.....	6
1.11 Student Organizations and Activities.....	8
1.12 Job Fairs, Internships, & Study Abroad.....	9
1.13 Graduation Honors.....	9
1.14 Financial Aid and Scholarships.....	9
1.15 Undergraduate Research.....	10
1.16 FE Exam.....	10
1.17 Graduate Study.....	10
2 The Curriculum	13
2.1 Overview of the Curriculum.....	13
2.1.1 Required Courses.....	13
2.1.2 Science Elective.....	14
2.1.3 Civil Engineering Technical Program.....	14
2.1.4 General Education Electives.....	17
2.1.5 Free Electives.....	18
2.2 Prerequisites.....	18
2.3 Independent Study and Special Topics Courses.....	18
2.4 Data Science Certificate.....	19
APPENDIX A. Civil Engineering Integrated Design Courses.....	20
APPENDIX B. Civil Engineering Courses with Lab Component.....	20
APPENDIX C. Design Content of Civil and Environmental Engineering Courses.....	20
3 The Academic Program Plan	24
3.1 What is the Academic Program Plan?.....	24
3.2 Development and Review of the Academic Program Plan.....	24
3.3 Submission of the Academic Program Plan.....	25
3.4 Monitoring and Assessment of Student Progress.....	25
3.5 Degree Audit.....	25
3.6 Going Above and Beyond the Program Requirements.....	25

3.7 Independent Study and Special Topics Courses	25
4 Typical Eight Semester Schedule	27
5 Advanced Technical Programs.....	31
General Advice on Selecting a Primary and Secondary Field	31
5.1 Organization of the Material in this Chapter.....	31
5.2 Construction Engineering and Management.....	32
5.3 Construction Materials Engineering	33
5.4 Environmental Engineering	34
5.5 Geotechnical Engineering.....	35
5.6 Structural Engineering.....	36
5.7 Transportation Engineering	37
5.8 Water Resources Engineering and Science.....	38
5.9 Energy-Water-Environment Sustainability.....	39
5.10 Societal Risk and Hazard Mitigation	40
5.11 Sustainable and Resilient Infrastructure Systems	41
5.12 Additional Civil Engineering Secondaries.....	42
5.13 Other Non-CEE Secondary Areas	44
5.14 The General Civil Engineering Option	45
6 Civil Engineering Courses.....	47
6.1 Semester Course Offerings	55
Academic Program Plan	60

1

Introduction

1.1 CEE Undergraduate Program Mission Statement and Program Educational Objectives

Civil and environmental engineers apply basic principles of science, supported by mathematical and computational tools, to address the biggest challenges facing society: ensuring clean air, safe drinking water and sanitation; addressing our changing environment; protecting the population from natural and man-made hazards; designing a sustainable infrastructure that serves everyone; reimagining human and commodity traffic for an automated future; and of course designing and constructing the world's tallest buildings and most iconic bridges. The *mission* of the Department of Civil and Environmental Engineering is to produce engineers, leaders, and scholars of the highest caliber who possess rigorous core knowledge and problem-solving skills; understand complex engineering and societal systems, and their interactions; and create innovative solutions that advance quality of life. We achieve this through our teaching, research, and service activities by educating, inspiring, and cultivating future leaders and thinkers who are prepared to meet 21st-century challenges.

The *program educational objectives* for the CEE program reflect the mission of the Department of Civil and Environmental Engineering. The University of Illinois Civil and Environmental Engineering program will produce graduates having the option, talents, and knowledge to:

1. pursue a diverse range of careers as engineers, consultants, and entrepreneurs in both traditional and emerging fields of civil and environmental engineering, science and, technology;
2. continue their formal education in leading graduate programs in engineering and interdisciplinary areas to emerge as researchers, experts, educators, and leaders;
3. pursue professional licensure and engage in professional skills development;
4. learn and create new knowledge in ever-changing environments of the 21st century, and communicate their work and ideas to colleagues, professional societies, and the public at large; and
5. practice and inspire high ethical and technical standards, and lead their professional disciplines, organizations, and communities globally.

The civil engineering program comprises seven traditional areas (construction engineering and management, construction materials engineering, environmental engineering, geotechnical engineering, structural engineering, transportation engineering, and water resources engineering and science) and three interdisciplinary programs (sustainable and resilient infrastructure systems; energy-water-environment sustainability; and societal risk and hazard mitigation). Although each area has its own special body of

knowledge and engineering tools, they all rely on the same fundamental core principles. Civil engineering projects often draw expertise from many of these areas and programs.

The civil engineering curriculum is designed to develop engineers who have a strong background in mathematics and science, engineers who are articulate, and engineers who understand the nature of their special role in society and the impact of their work on the progress of civilization. The curriculum is designed to guarantee a certain breadth of knowledge in the civil engineering disciplines through a set of core courses, as well as to ensure depth and focus in certain disciplines through a primary and secondary area of specialization. The curriculum develops the basic engineering tools necessary to solve problems in the field of civil engineering, as well as opportunities to explore where the state-of-practice is headed in civil engineering.

1.2 Department of Civil and Environmental Engineering – An Overview

The Department of Civil Engineering was founded in 1871, having been one of the four branches of the Polytechnic Department since 1867—the year the University of Illinois was founded. In 1998 the name of the department was changed to Civil and Environmental Engineering (CEE). Today the department has an outstanding reputation for undergraduate and graduate education and for civil engineering research and public service. *U.S. News and World Report* in its annual survey consistently ranks the department in general and the CEE undergraduate program in particular as one of the very top civil engineering programs in the country.

The department consists of about 60 faculty, 700 undergraduate students, and 500 graduate students. The department is in Newmark Civil Engineering Laboratory / Yeh Student Center Building and the CEE Building on the UIUC campus. The department has several research laboratories Illinois Center for Transportation (ICT), Research and Innovation Laboratory (RAIL), the Newmark Structural Engineering Laboratory, the Ven Te Chow Hydrosystems Laboratory, the Environmental Engineering Labs, the Rock Mechanics Laboratory, John T. Pfeffer Sanitation and Resource Recovery Laboratory, Wind Engineering Research Laboratory, and Advanced Transportation Research and Engineering Lab (ATREL). Department faculty are engaged in numerous research endeavors, and many of them hold positions of influence and responsibility in national and international engineering organizations and serve on advisory councils and governmental commissions. Through their research and teaching, the faculty members of the department are educating the next generation of civil engineers to be leaders of an evolving profession that will assure a high quality of life for our civilized world.

Faculty and alumni of our program have contributed to some of the greatest civil engineering achievements in the world. Examples include the Golden Gate Bridge, the Hoover Dam, the Trans-Alaska Pipeline, the Willis (Sears) Tower, the Petronas Twin Towers in Kuala Lumpur, and Burj Khalifa in Dubai. The Department of Civil and Environmental Engineering boasts one of the largest alumni associations in the world, with over 15,000 graduates. Illinois civil engineering graduates are sought after because they are well prepared to make a positive impact. When you graduate from the University of Illinois with a degree in civil engineering, you go out with not only an excellent education, but also the reputation, stature, and recognition that your forebearers have worked hard to develop and maintain.

1.3 The Department of Civil and Environmental Engineering

The Department of Civil and Environmental Engineering Department Head is Professor Anna Barros, Professor John Popovics and Professor Scott Olson are Associate Heads of the department in charge of undergraduate and graduate affairs.

Department of Civil and Environmental Engineering
Newmark Civil Engineering Laboratory (NCEL)
205 North Mathews Avenue
Urbana, Illinois 61801
<http://cee.illinois.edu/>

Department Head

Anna Barros	1114 NCEL	265-6955	barros@illinois.edu
Vicki Dixon	1114 NCEL	244-0857	vdixon@illinois.edu
Mike Uhall	1111B NCEL	300-4431	uhall2@illinois.edu

Associate Head & Director of Undergraduate Studies

John Popovics	1116 NCEL	244-0843	jonpop@illinois.edu
Becky Stillwell	1102 NCEL	333-3812	rborden@illinois.edu
Pascal Youakim	1117 NCEL	300-2424	youakim2@illinois.edu
Greg Coughlin	1105 NCEL	265-5539	gcoughli@illinois.edu

Associate Head & Director of Graduate Programs

Scott Olson	1110 NCEL	265-7584	olson@illinois.edu
Brittany Meeker	1108 NCEL	265-0395	bmeeker@illinois.edu
Katya Trubitsyna	1104 NCEL	300-0194	katia@illinois.edu

1.4 Department of Civil and Environmental Engineering Undergraduate Program

This section gives a summary of the responsibilities and expectations of each participant who advises or supports the undergraduate program in Civil and Environmental Engineering.

The Associate Head: The Associate Head & Director of Undergraduate Studies oversees the undergraduate program and is responsible for administering undergraduate advising policies. The Associate Head is responsible for supervising all personnel involved in the undergraduate program. The Associate Head is also the point of contact for grievances related to the classroom (course conduct and grading).

Professor John Popovics
1116 Newmark Civil Engineering Laboratory
(217) 244-0843
johnpop@illinois.edu

The Assistant Director of Undergraduate Programs: This position works directly with the CEE Associate Head & Director of Undergraduate Studies. The Assistant Director of Undergraduate Programs advises students on navigation of the CEE undergraduate curriculum, campus, college, and department requirements for graduation. This position also monitors the academic progress of all students, works closely with students in establishing study abroad credit and transfer credit. The Assistant Director of Undergraduate Programs is responsible for supervising both the Academic Advisor and Undergraduate Program Coordinator positions.

Becky Stillwell
1102 Newmark Civil Engineering Laboratory
(217) 333-3812
rborden@illinois.edu

The Academic Advisor: This position works directly with the CEE Associate Head & Director of Undergraduate Studies, and The Assistant Director of Undergraduate Programs. Advises students on navigation of the CEE undergraduate curriculum, campus, college, and department requirements for graduation. The Academic Advisor monitors the academic progress of all students. This position works closely with students in establishing study abroad and/or transfer credit and manages Academic Program Plans. The Academic Advisor oversees the department scholarships and is the department's main contact.

Pascal Youakim
1117 Newmark Civil Engineering Laboratory
(217) 300-2424
youakim2@illinois.edu

The Undergraduate Program Coordinator: is responsible for undergraduate student records, class scheduling, classroom reservations, textbook orders, final exams, ICES forms, and supporting the Assistant Director of Undergraduate Programs.

Gregory Coughlin
1105 Newmark Civil Engineering Laboratory,
(217) 265-5539,
gcoughli@illinois.edu

The Assistant Director of Alumni and Corporate Relations: is responsible for Fall and spring job fairs, backpack-to-briefcase, professional development, alumni, and student events. This position works closely with the CEEAA alumni board in making connections with students and the department.

Keely Ashman
2112 Newmark Civil Engineering Laboratory,
(217) 333-6454
kashman@illinois.edu

The Faculty Advisor: Each member of the CEE faculty has been assigned undergraduate advisees. Your faculty advisor can serve as a resource for learning how to improve your study habits and other life skills that are needed to excel in our program. The faculty advisor is also a good resource for discussing curricular and career decisions.

You should get to know your faculty advisor better and visit him/her two or three times a year. A good working relationship with your faculty advisor can help you succeed in our program. If you feel there is an advisor within your discipline who could be more beneficial to you, please reach out to the Academic Advisor about requesting a change.

1.5 Grainger College of Engineering

The Grainger College of Engineering offers advice for all engineering students, particularly for questions that are outside the domain of specific departments. Website: <https://grainger.illinois.edu/>

Undergraduate Programs Office

4 th Floor of Grainger Library	333-2280	
http://engineering.illinois.edu/academics/undergraduate/		
Jonathan Makela, Assoc. Dean		jmakela@illinois.edu
Ivan Favila, Asst. Dean		ifavila@illinois.edu
Kerri Green, Asst. Dean		kgreen0@illinois.edu
Emad Jassim, Asst. Dean		jassim@illinois.edu
Brian Woodard, Asst. Dean		bswoodrd@illinois.edu
Corey Flack, Assistant Director		flack3@illinois.edu
Stacey Albers, Academic Advisor		stalbers@illinois.edu
Rachel Brown, Academic Advisor		rachel35@illinois.edu
Sean McKee Academic Advisor		stmckee@illinois.edu
Chris Migotsky, Academic Advisor		migotsky@illinois.edu

Center for Academic Resources in Engineering (CARE)

Ivan Favila - Director		
4 th Floor Grainger Engineering Library	244-2678	enrg-care@illinois.edu
https://care.grainger.illinois.edu/		

Engineering Career Services (ECS)

Leigh Deusinger - Director		
3270 Digital Computer Lab	333-1960	ecs@enrg.illinois.edu
https://ecs.engineering.illinois.edu/		

International Programs in Engineering (IPENG)

Kate Abney - Director		
3300 Digital Computer Lab	244-0054	ipeng@illinois.edu
https://students.grainger.illinois.edu/ipeng/home/		

Grainger College of Engineering Undergraduate Program Office (UPO): The Office of Undergraduate Programs is located on the 4th Floor of Grainger Library. The Assistant Deans and advising staff are available for advising and academic matters. They maintain undergraduate student records in the Grainger College of Engineering and monitor student progress. They administer all academic issues that involve more than one department (e.g., interdepartmental transfers).

1.6 James Scholar Honors Program

James Scholar Honors is a college-level honors program that allows you extra academic experiences. James Scholars have priority registration for classes and have the opportunity to take honors-only courses and receive a special distinction when they graduate.

First Year Students are invited to participate during their first semester. Students may self-nominate through the James Scholar portal in the first 10 days of class each semester, after they have been on campus one semester and if they meet the 3.50 GPA requirement; they are required to take one honors course per year. Class sections are designated with an "H" at the end of their section designation.

Honors Credit Learning Agreement (HCLA): This represents an agreement between you and the instructor regarding the additional work to be completed in a course to receive honors credit. This can be

done for any course with instructor approval. You will receive honors credit for the course.

The upper-class James Scholar Program involves sophomores, juniors, and senior students who have achieved a minimum cumulative University of Illinois GPA of 3.50 and who are therefore eligible to apply to be an Engineering James Scholar. Applications are accepted during the first ten days of class in the fall and spring semesters. <https://students.grainger.illinois.edu/jscholar/about/>

1.7 Center for Academic Resources in Engineering (CARE)

The Center for Academic Resources in Engineering (CARE) creates a dynamic learning community where services, resources, and expertise converge to support engineering students as they work to realize their academic, professional, and personal aspirations.

At CARE, students find an engaging commons area designed to encourage interaction and collaboration. Scheduled and on-demand tutoring, study groups, teaching assistants, and a variety of resources are available to help students excel.

With 20,000 sq. ft of space spanning the entire fourth floor of the Grainger Engineering Library, CARE offers a variety of designated areas for group study, individual study, tutoring, computer workstations, course study halls, and workshops. Rooms can be reserved for study groups, tutoring, practicing presentations, workshops, videoconferencing, and other activities. <https://care.grainger.illinois.edu/>

1.8 Engineering Career Services

Engineering Career Services (ECS) assists students in developing the skills to transform their unique talents and interests into meaningful careers and professional pathways. ECS hosts career fairs, provides seminars, and arranges on-campus interviews to provide employment opportunities for students. For more information about ECS, please visit their website: <http://ecs.engineering.illinois.edu/>

1.9 International Programs in Engineering (IPENG)

The Grainger College of Engineering study abroad office. Our portfolio includes exchange programs, direct enroll programs, providers programs, customized short-term programs, and signature programs. Our staff is a group of dedicated and knowledgeable educational professionals whose own international experience has impacted our careers.

You can fit an international experience into your Engineering schedule. There is a wide array of opportunities from studying, interning, researching, or volunteering abroad to on-campus activities such pursuing an International Minor or participating in Global Engineering Ambassadors.

Being a global engineer is invaluable! Employers seek job applicants with international experience and intercultural skills. These experiences can be a deciding factor in selecting new employees.

1.10 Academics

There are certain rules and regulations that may be especially important to your life at the University of Illinois. The Student Code documents these issues in detail.

Course Grade: Grades at the University of Illinois are based on the traditional four-point scale (i.e., A=4, B=3, C=2, D=1, F=0). An instructor may elect to distinguish a grade with a plus or a minus. A

plus adds 0.333 to the basic grade value and a minus subtracts 0.333 from the basic grade value (e.g., a B+ is worth 3.333 points and a C- is worth 1.667 points). The only exception is the A+, which is simply worth 4 points. The rules associated with the grading system at the University of Illinois are described in the Student Code in Sections 3-101 through 3-104.

If you retake a course – a very good idea for any technical course for which you earn a grade lower than C- (see Section 2.3 for advice on this matter) – the original grade also remains on your transcript, as if it were a different course, and both grades are included in calculating your GPA.

Credit/No Credit Option: The credit/no credit option is designed to encourage students to explore subjects that they might otherwise avoid. The rules concerning the credit/no credit option are described in the Student Code in Section 3-105. To briefly summarize those rules, note that (1) all required courses are taken for a grade, (2) all core and technical courses are taken for a grade, and (3) humanities and social science are taken for a grade. Free electives can be used for credit/no credit option.
<https://advising.grainger.illinois.edu/course-registration/credit-no-credit>

Grade Replacement: All undergraduate students can earn a new grade and replace it with the grade received in the first attempt. The policy places some limits on courses and hours that can be replaced. Undergraduates in the Grainger College of Engineering can use an online portal to request a current course be used for grade replacement. For more information about this policy please see the website below.
<https://advising.grainger.illinois.edu/course-registration/grade-replacement>

Residency Requirements for a Degree: In addition to specific course and scholastic average requirements, each candidate for a bachelor's degree from the University of Illinois at Urbana-Champaign (UIUC) must earn at least 60 semester hours of UIUC credit, of which at least 21 hours must be 300 or 400 level courses at UIUC.

Restrictions on Dropping Courses: Students may freely drop any “unrestricted” course up to mid-term as long as they remain full time with 12 or more credit hours.

Students who wish to drop a class after the campus deadline MUST have extenuating circumstances beyond their control that directly affected their academic performance – e.g., documented illness, personal emergency, or crisis, etc. Requests of this nature must be well supported through documentation.

College Restricted Courses: CHEM 102/103 & 104/105, CS 101 & 124, MATH 220/221, 231, 241 & 285, PHYS 211, 212 & 213, and RHET 105. A drop requires approval from a Dean in the Undergraduate Programs Office, 4th Floor of Grainger Library.

Civil Engineering Restricted Courses: CEE 190, 201, 202, 331 and TAM 211, 212, 251 & 335. A drop requires approval from the Chief Advisor of the student's home department and a Dean in the Undergraduate Programs Office, 4th Floor Grainger Library.

Academic Probation and Rules: The general idea of probation and drop at UIUC is very simple. To earn a degree from UIUC you must have a cumulative GPA of 2.0 or better. If your semester GPA is below 2.0 in any one semester, then you are placed on academic probation. If you fail to meet your probation requirements, then you are dismissed from the university. If your semester GPA is below 1.0, you are immediately dismissed, without probation. <https://advising.grainger.illinois.edu/academic-standing/academic-probation>

Academic Integrity: Infractions of academic integrity, such as cheating and plagiarism, are not tolerated at the University of Illinois. The rules that govern the academic integrity of all students are covered in Section 1-402 of the Student Code: <https://studentcode.illinois.edu/article1/part4/1-402/>.

1.11 Registered Student Organizations (RSO's)

The Department of Civil and Environmental Engineering provides an excellent opportunity to supplement classroom education through contact with other students, faculty, and practicing engineers. Student organizations bring in speakers from various engineering fields, sponsor field trips to construction and manufacturing sites, and coordinate Engineering Open House. All student groups hold regular meetings, most of which are open to non-members. The student groups have websites that give information about the officers, requirements for joining, lists of activities, and other information. To contact these organizations, please visit their website: <https://cee.illinois.edu/student-life/student-organizations>

Student Organizations in CEE

ACI	American Concrete Institute
AREMA	American Railway Engineering and Maintenance-of-Way Assoc.
ASCE	American Society of Civil Engineers
CCT	Concrete Canoe Team
EERI	Earthquake Engineering Research Institute
EIA	Engineers in Action Bridge Program
EMBRACE	Empowering Minorities and Building Representation Across Civil and Environmental Engineering
GESO	Geotechnical Engineering Student Organization
IAHR	International Association for Hydraulic Research
ISD	Illinois Solar Decathlon
ITE	Institute of Transportation Engineers
IWRA	International Water Resources Association
SBT	Steel Bridge Team
XE	Chi Epsilon - Civil Engineering Honor Society
WCEE	Women in CEE

Student Organizations in Grainger

EC	Engineering Council
EWB	Engineers Without Borders
NSBE	National Society of Black Engineers
SHPE	Society of Hispanic Professional Engineers
SWE	Society of Women Engineers
TBP	Tau Beta Pi - Engineering Honor Society

1.10 Job Fairs, Internships and Study Abroad

There are excellent opportunities available to students for providing practical experience away from campus. Among these are the cooperative education program, internships, and the study abroad program.

Job Fairs: The Department of Civil and Environmental Engineering offers a Job Fair in September and February. The September event is a two-day fair with over 100 Civil and Environmental Engineering companies and recruiters available to speak to students about internships and full-time positions. This event is unique to our department and is different from others job fairs in the fact that it caters to our students in CEE, and not all engineering students, like the Engineering Career Services (ECS) fair does. They too offer fairs in September and February. For more information about the CEE event please see this website: <https://cee.illinois.edu/student-life/career-prep/job-fair-cee-students>

Internships: Summer internships are highly recommended. Most civil engineering students will have more than one internship experience before graduation. The summers are excellent opportunities to gain two or three months of hands-on experience. The practical experience and opportunity to get to know professional engineers can be key factors in your search for a permanent position after graduation. Academic credit is not given for work experience. Summer internships are often obtained through the CEE job fairs and/or other networking activities.

Study Abroad: Study abroad is the pursuit of educational opportunities and activities in an international setting. These come in many different shapes and sizes, as they vary in academic objectives, length, location, and price. Studying abroad can truly be a life-changing experience. Studying abroad prepares students in many ways for today's global world by adding value to their education, allowing them to earn academic credit abroad, enhancing employability, improving intercultural competence, heightening intercultural communication skills, and giving students access to new information, technologies and skills. Most students find it best to schedule study abroad during their sophomore or junior year.

The Assistant Director of Undergraduate Programs can work with you to establish a program of study. You must gather all the relevant information from the institution you will be attending abroad and then meet with the Assistant Director of Undergraduate Programs or the Academic Advisor before you leave. It is very important to have all your courses well documented (i.e., with a course syllabus and other information).

1.11 Graduation Honors

Honors awarded at graduation are designated as Honors, High Honors, and Highest Honors. The designation of Honors is awarded automatically to a student who has a cumulative UIUC grade-point-average (GPA) of at least 3.5 at graduation. The designation of High Honors is automatically awarded to a student with at least a 3.8 GPA. To qualify for Highest Honors, a student must not only meet the GPA requirement for High Honors, but also must have demonstrated outstanding performance in supplementary activities of an academic, professional and/or extracurricular nature.

1.12 Financial Aid and Scholarships

Financial aid for undergraduate students is available from many sources. Coordination of the allocation of these funds is, in general, the responsibility of the Office of Student Financial Aid (in the Student Services Arcade Building, 620 E. John, 333-0100).

Civil and Environmental Engineering Scholarships and Awards: The Department of Civil and Environmental Engineering has many awards and scholarships given each year. These scholarships are established through the generous donations of alumni, private individuals, and industry sources. One

application is used for all CEE awards and scholarships. The online application is available on the undergraduate newsletter. The deadline for submission of applications is in late January, after winter break.

Grainger Engineering Scholarships and Awards: In addition to the sources of financial aid that are available to all university students, undergraduate students in civil and environmental engineering may be eligible for scholarships that are administered by the Grainger College of Engineering.

1.13 Undergraduate Research

Undergraduate research is an excellent way to accomplish several goals. First, it exposes you to the notion of research as one of the many opportunities the university provides and that engineers do as a career outcome. Second, it can provide you with an experience that will distinguish you from your peers. Third, the experience brings a close working relationship with a member of the faculty and with graduate students.

CEE REU (Research Experience for Undergraduates): The CEE REU Program is designed to expose undergraduate students to research and encourage CEE faculty to engage undergraduate students in research early in their academic career. Undergraduate students are encouraged to develop a brief research proposal with a CEE faculty member, in an area of their mutual interest. If selected for funding, the student will be paid \$1,680 per semester. The program will be announced within two weeks of the start of each semester (Fall, Spring, and Summer II). Requests for proposals will be sent by email from the Academic Advisor to provide interested faculty and UG students with the exact deadlines and other program requirements.

Proposals can only be submitted by CEE faculty members on behalf of their students – each faculty member is limited to 2 students per calendar year, and students are eligible for two REUs during their undergraduate studies. The length of employment will be 12 weeks (10 hrs per week) in the Fall and Spring semesters, and 6 weeks (20 hrs per week) in the Summer, at a rate of \$1400 per hour.

It is the hope of the program to promote interactions between faculty and undergraduate students. In many cases, if an undergraduate can prove his/her value and contribution to their faculty advisor's research program, they may subsequently be directly funded by one of the faculty member's research projects. The REU experience, and in some cases research publications, may be very helpful in your job search and/or graduate school application process. The CEE REU program is mainly intended for new UG research opportunities; therefore, it is not necessarily applicable to undergraduate students who are already working for a faculty member.

1.14 FE Exam

Fundamentals of Engineering (FE) and Fundamentals of Surveying (FS) exams have transitioned to computer-based testing and are now administered exclusively at approved Pearson VUE test centers. Computer-based testing provides many advantages. Examinees are now able to schedule their exam at a time and location that works best for them and then receive their results within 7 to 10 days. Please visit <http://ncees.org/exams/> to register for the exam. Students in CEE should register for the FE Civil exam or FE Environmental exam.

1.15 Graduate Study

Nearly half of the students who graduate from the civil engineering program here at UIUC go on to pursue graduate study. While a B.S. degree in civil engineering provides a solid educational foundation for many career options, employers' place high value on the M.S. degree. In certain disciplines, an M.S.

degree is required for some entry-level positions. Graduate programs, admission requirements, and financial aid programs for graduate students vary significantly among universities. Detailed information about the graduate programs for the department is available here:

<https://cee.illinois.edu/admissions/graduate>

Graduate Study at UIUC: One of the most direct routes to a graduate program is simply to continue your studies at UIUC. Students who are within 5 semester hours of completing the B.S. degree requirements may apply for early admission to the Graduate College and, if admitted, can complete their B.S. degree while enrolled as a graduate student.

CEE undergraduates in their final year of study at UIUC may use the Simple Entry Program to apply to a CEE master's degree (non-Thesis) program. These students are not required to take the GRE or submit references to apply.

Students choosing to apply by "Simple Entry" should be interested in the non-thesis track for their M.S. program. The non-thesis track may facilitate completion of the M.S. degree within as little as a 12-month period. It is important to realize that most graduate scholarship/fellowship programs and research opportunities at Illinois require GRE scores and letters of recommendation. For many students not interested in research and able to fund their own M.S. program, the simple entry is an attractive option.

<https://cee.illinois.edu/admissions/graduate/simple-entry-program-cee-undergraduates>

If you do not choose the simple entry option, you will be required to take the GRE and submit your scores as part of your application to graduate school. GRE test scores are currently optional for all CEE graduate school applicants. However, it is strongly recommended that the GRE test be submitted to help faculty with admission and funding decisions for all PhD applicants. CEE also recommends the GRE test for MS applications, particularly for students applying from international universities, MS applicants looking for potential funding support, or MS applicants whose GPA falls below the average GPA of admitted students.

GRE test scores are currently *optional* for all CEE graduate school applicants. However, it is strongly recommended that the GRE test be submitted to help faculty with admission and funding decisions for all PhD applicants. CEE also recommends the GRE test for MS applications, particularly for students applying from international universities, MS applicants looking for potential funding support, or MS applicants whose GPA falls below the average GPA of admitted students.

GRE General Test - averages for CEE applicants approved for admission:

- Verbal: 155
- Quantitative: 165
- Analytical Writing: 4.0

Information about test dates and locations can be found on the [GRE website](#).

The GRE is administered by the [Educational Testing Service](#).

Please plan ahead so that your official GRE scores will arrive to UIUC by your [application deadline](#). Applicants should request that the Educational Testing Service send GRE scores to the University of Illinois at Urbana-Champaign using our **institution code number 1836**.

2

The Curriculum

2.1 Overview of the Curriculum

The curriculum leading to the degree of Bachelor of Science in Civil Engineering requires 128 hours and is organized into required courses; a science elective; civil engineering technical courses; and other electives. A summary of the program follows.

2.1.1 Required Courses (67 hours)

The following courses, associated with 67 semester hours of academic credit, are required as part of the undergraduate curriculum in civil engineering. These courses provide the foundation for the study of civil engineering.

Orientation and professional development (1 credit hour)

ENG 100	Engineering Lecture (freshmen only)	1 hrs
ENG 300	Engineering Transfer Lecture (transfer students only)	1 hrs
CEE 190	Project-Based Introduction to CEE	4 hrs
CEE 495	Professional Practice	0 hrs

Mathematics (16 hours)

MATH 221	Calculus I	4 hrs
MATH 257	Linear Algebra with Computational Applications ❖	3 hrs
MATH 231	Calculus II	3 hrs
MATH 241	Calculus III	4 hrs
MATH 285	Intro Differential Equations †	3 hrs

❖ MATH 415 Linear Algebra (3 hrs) can be substituted.

† MATH 284 Intro Differential Systems (4 hrs) can be substituted.

† MATH 286 Intro to Differential Equation Plus (4 hrs) can be substituted.

Basic Sciences (18 hours)

CHEM 102	General Chemistry I	3 hrs
CHEM 103	General Chemistry Lab I (to be taken with CHEM 102)	1 hrs
CHEM 104	General Chemistry II	3 hrs
CHEM 105	General Chemistry Lab II (to be taken with CHEM 104)	1 hrs
PHYS 211	Univ Physics, Mechanics	4 hrs
PHYS 212	Univ Physics, Elec & Mag	4 hrs

PHYS 213	Univ Physics, Thermal Physics	2 hrs
----------	-------------------------------	-------

Applied Mechanics (13 hours)

TAM 211	Statics	3 hrs
TAM 212	Introductory Dynamics	3 hrs
TAM 251	Introductory Solid Mechanics	3 hrs
TAM 335	Introductory Fluid Mechanics	4 hrs

Written Communication (8 hours)

RHET 105	Principles of Composition	4 hrs
CEE 300	Behaviors of Materials (Adv Comp.) OR	4 hrs
CEE 340	Energy and the Global Environment	3 hrs

Fundamental Engineering Principles and Tools (12 hours)

CS 101	Intro Computing: Engrg & Sci	3 hrs
SE 101	Engineering Graphics & Design	3 hrs
CEE 201	Systems Engrg & Economics	3 hrs
CEE 202	Engineering Risk & Uncertainty	3 hrs

⚡ CEE 331 Fluid Mechanics in the Natural and Built Environment (4 hrs) can be substituted.

⚡ CS 124 Introduction to Computer Science I (3 hrs) can be substituted.

2.1.2 Science Elective (3 hours)

Each student must select at least three (3) credit hours for an elective course in science. The elective allows the student to gain additional depth in science. The course should be selected according to the requirements and recommendations for the chosen primary field, as specified in Chapter 5, Advanced Technical Programs. It may be possible to gain approval for a course that is not included on the recommended list for a primary; however, the merit of including the course in your program must be justified on the Academic Program Plan and the course is subject to approval through the program review process. You should obtain approval for such a course from the Associate Head & Director of Undergraduate Studies before you can take the course and put it on your Academic Program Plan.

2.1.3 Civil Engineering Technical Program (34 hours)

The civil engineering technical program is designed to give each student a broad background in the disciplines of civil engineering through the core courses and to allow each student to develop a focused program through advanced technical courses in chosen primary and secondary areas of emphasis. The fundamental principles of civil engineering design and the behavior of civil engineering systems are emphasized throughout the program.

This section describes the civil engineering technical program. Briefly, there are two types of civil engineering courses: (1) core courses and (2) advanced technical elective courses. The core courses provide the prerequisites to all of the advanced technical courses. The advanced technical courses are subdivided into a primary area of emphasis and a secondary area of emphasis. The core and secondary area courses assure adequate breadth in civil engineering subjects, while the primary area courses allow the student to study a certain subject in great depth. For the student who wishes to gain a broader education in civil engineering, we provide the General Option, which is described in Section 5.11.

You cannot use an advanced technical course to meet both your primary and secondary requirements. You must have 12 hours from your primary and 6 hours from your secondary. The sum of the semester hours of core courses and technical electives must be at least 34.

2.1.3.1 Civil Engineering Core Courses

At least 15 hours of credit (five courses) must be core civil engineering courses. The courses are selected from the following list:

CEE 300	Behavior of Materials	4 hrs
CEE 310	Transportation Engineering	3 hrs
CEE 320	Construction Engineering	3 hrs
CEE 330	Environmental Engineering	3 hrs
CEE 340	Energy and Global Environment	3 hrs
CEE 350	Water Resources Engineering	3 hrs
CEE 360	Structural Engineering	3 hrs
CEE 380	Geotechnical Engineering	3 hrs

- **Core courses cannot be used as advanced technical courses.**

2.1.3.2 Advanced Technical Electives

The advanced technical electives are selected to satisfy the requirements of a primary area of emphasis (i.e., a major field within civil engineering) and a secondary area of emphasis (i.e., a minor field within civil engineering). The program must have at least 12 hours in the primary field and 6 hours in the secondary field.

Primary Area: (12 hours minimum). The courses in the primary area are chosen to be an appropriate program of study within one of the ten disciplines of civil engineering: (1) construction engineering and management, (2) construction materials engineering, (3) environmental engineering, (4) geotechnical engineering, (5) structural engineering, (6) transportation engineering, (7) water resources engineering and science, (8) energy-water-environment sustainability (EWES), (9) societal risk and hazard mitigation (SRHM), and (10) sustainable and resilient infrastructure systems (SRIS). Pre-approved programs in each of the areas are listed in Chapter 5, Advanced Technical Programs. Deviations from the pre-approved programs are possible, but subject to the program review process. You must contact the Associate Head & Director of Undergraduate Studies or the Academic Advisor in advance of any deviations from the pre-approved programs.

The value of focusing on one area of study through the primary area courses is twofold. First, it provides a basic education that allows a B.S. graduate to work productively in that field. Second, it provides an education that prepares the student for graduate work in that field.

Guidelines for putting together a primary program in each of the ten disciplines of civil and environmental engineering are described in Chapter 5. Note that each program of study has requirements and recommendations on science electives and civil engineering core courses. Programs in the ten disciplines can be petitioned through the Academic Program Plan, which is described in Chapter 3.

Secondary Area: (6 hours minimum). The courses in the secondary area of emphasis are chosen to complement the primary area and add breadth to the program of study. Pre-approved secondary programs are listed in Chapter 5, Advanced Technical Programs.

Courses that make up a secondary area can be taken in one of the ten disciplines of civil and environmental engineering, but there are also some additional options that give flexibility to the program. A secondary program cannot be taken in the same area as the primary, nor is it advisable to have primary and secondary areas only in the CEE interdisciplinary programs of EWES, SRHM, and SRIS. The secondary area requirement is meant to provide the student with additional breadth as well as an additional area of special focus. Guidelines for putting together a secondary program in each of the ten disciplines of civil and environmental engineering are described in Chapter 5.

A secondary program outside of the ten civil engineering disciplines is possible but is subject to the program review process. Some secondary programs that have already been approved are described in Section 5.10. Some ideas on how the secondary area courses can be used include the following (the specific courses for which are still subject to approval):

- (1) The student may wish to pursue study of an engineering field outside of but related to civil and environmental engineering. The secondary area electives could be selected to achieve this goal.
- (2) The student may want to pursue a minor (e.g., there are official minors currently available in both Mathematics and Computer Science). Judiciously selected courses, carefully justified, may allow progress toward the minor while, at the same time, satisfying the secondary area requirement. The science electives might also be useful for this purpose. (Of course, free electives can also help defray the time it takes to earn a minor).
- (3) The student may have plans to pursue a professional degree in law, business administration, or medicine after completion of a B.S. in civil engineering. Judiciously selected courses, carefully justified, may allow completion of some of the pre-professional courses required for entrance to certain professional programs. (Of course, free electives can again also be used for these purposes).

The Program Review Committee will look for solid evidence that any proposed program satisfies three basic criteria: (1) the proposed program is not at odds with nor does it dilute the established educational objectives associated with a B.S. degree in civil engineering, (2) the program must be coherent and have clear educational objectives, and (3) the proposed program must be clearly beneficial to the career objectives of the student. The case for a novel program must be made under the *Explanatory Notes and Comments* section of the Academic Program Plan described in Chapter 3. You should obtain preliminary approval for a novel program from the Associate Head & Director of Undergraduate Studies before submitting your Academic Program Plan and before taking any classes in the program.

The General Option: A student who wants a broad civil engineering education can elect the General Civil Engineering option (the General Option, for short). The specific course requirements of the General Option are described in Chapter 5. Students who are interested in the General Option are encouraged to discuss it with the Assistant Director of Undergraduate Programs.

Curricular Requirements Associated with Engineering Design: The concept of "engineering design" is central to the study of civil engineering. The term "design" means different things to different people, but in the context of civil engineering, we mean the process of using fundamental engineering principles in the creation of some facility or process to solve engineering problems or to meet societal demand, such as building a bridge or designing a water treatment plant. The key ideas are creation and synthesis. Almost every class in the civil engineering course catalog (see Chapter 6) is a combination of

fundamental ideas and their implementation through engineering design. Therefore, each course has some design content associated with it (there are a few exceptions).

Some civil engineering courses have an integrated design project required as part of the course work. The integrated design project provides engineering design experience based upon knowledge and skills acquired earlier. The design experience incorporates engineering standards and realistic engineering constraints, and it can generally include economic, social, and/or political concerns as well.

The technical program selected by a student must meet the following two criteria for engineering design:

- (1) Each student must take at least one course having an integrated design project with multidisciplinary teams. The currently approved courses from which students may select are listed at the end of this chapter in Appendix A, Integrated Design Courses.
- (2) The cumulative engineering design content in the program must be at least 16 hours, where the hours of design content for each course are specified in Appendix B, Design Content of Civil and Environmental Engineering Courses, given at the end of this chapter. Note that only 13 hours of design are required on the Academic Program Plan because the required courses CEE 201 and CEE 202 (which do not appear on the Academic Program Plan) account for 3 hours of design content.

Curricular Requirements Associated with Physical Laboratories: Physical laboratory experiences are an essential part of an engineering education. For certain concepts there is no substitute for putting hands on and making observations. There are physical laboratory components to some of the required courses (e.g., the chemistry and physics classes, and even TAM 335—Introductory Fluid Mechanics for CEE). In addition to the laboratories in required courses, each student must complete one additional core or advanced technical CEE course that has a physical laboratory. This course must be indicated on the Academic Program Plan. Acceptable laboratory courses are listed at the end of this chapter in Appendix C, Civil Engineering Courses with a Laboratory Component.

2.1.4 General Education Electives (12 hours)

The campus General Education requirements in social and behavioral sciences and in humanities and the arts can be met while satisfying the College of Engineering's liberal education course work requirements (see below). Proper choices will ensure that these courses also satisfy the campus requirements in the areas of Western and non-Western cultures. Beginning with the class that entered in Fall 2018, students must also assure that they take a course that satisfies the campus requirement in the area of U.S. Minority Culture. Many of these courses satisfy the campus Advanced Composition requirement, which assures that students have the advanced writing skills expected of all college graduates.

Students may obtain credit from different academic sources, i.e., residential instruction, advanced placement (AP or IB) tests, and transfer credits. *All course work taken to satisfy campus general education requirements must be taken for grade.*

- For students enrolled in [Academic Catalog years 2022-2023 and beyond](#): The Grainger College of Engineering requirements for the General Education requirements are **12 hours** consisting of the following:
 - ❖ 6 hours of campus GenEd courses in Humanities & the Arts. *
 - ❖ 6 hours of campus GenEd courses in Social & Behavioral Sciences. *

- For students enrolled in [Academic Catalog years](#) prior to 2022-2023: The Grainger College of Engineering requirements for the General Education requirements are **18 hours** consisting of the following:
 - ❖ 6 hours of campus GenEd courses in Humanities & the Arts. *
 - ❖ 6 hours of campus GenEd courses in Social & Behavioral Sciences. *
 - ❖ 6 hours from any of the following:
 1. Courses from The Grainger College of Engineering [Liberal Education course list](#). **
 2. Courses from the Humanities & the Arts campus GenEd list
 3. Courses from the Social & Behavioral Sciences campus GenEd list
 4. Courses that have a Cultural Studies designation

The Economics Requirement: For civil engineering, either ECON 102 (Microeconomic Principles) or ECON 103 (Macroeconomic Principles) must be included in the 18 hours of humanities and social sciences. The curriculum committee recommends ECON 102 over ECON 103 because the principles of microeconomics are particularly relevant to many of the possible career paths in civil engineering.

The Advanced Composition Requirement: The Advanced Composition requirement provides an intensive writing course whose goals are to improve understanding of critical issues within a substantive discipline and improve mastery of technical aspects of writing. CEE 300 – Behavior of Materials or CEE 340 – Energy and the Global Environment satisfy this requirement.

2.1.5 Free Electives (10 hours)

Undergraduate students in the Grainger College of Engineering have 10 (ten) or more semester hours of free electives; the exact number required depends on the major. * Almost all courses offered by the University, and most transfer courses, can be used for free electives for restrictions on these courses please see the website: <https://advising.grainger.illinois.edu/degree-requirements/free-electives>

*Undergraduate students in the Grainger College of Engineering enrolled in [Academic Catalog years](#) prior to 2022-2023 have 6 (six) or more semester hours of free electives; the exact number depends on the major.

2.2 Prerequisites

The study of engineering is a process of building on fundamental knowledge. Hence, the prerequisite structure of the courses is extremely important. Prerequisites, as listed in the course catalog, are meant to be a guide to what you are expected to know when you start a certain course. Your success in any course depends strongly upon your mastery of the prerequisite material. For quick reference to the courses in the CEE curriculum and the needed prerequisites please see this website: [Civil Engineering Course Map](#)

2.3 Independent Study and Special Topics Courses

A student may take an independent study (i.e., CEE 497) or a special topics course (i.e., CEE 398 or 498) in partial fulfillment for the degree requirements. Such a course can count as a technical elective in the primary or secondary field and is subject to the program review process. There are many good reasons to include such courses in your curriculum. Some advice on these courses is given below.

Independent Study (CEE 497): An independent study is a self-paced study of a particular topic, carried out under the guidance of a faculty member. Each faculty member has his or her own section

number. An independent study must be taken for a grade if it is to be used toward graduation requirements as a technical elective. Independent study provides an opportunity to include research in your undergraduate program.

Each faculty member has a different style in directing independent studies. It is essential to establish, in advance and in writing, a clear scope of the work to be done and expected products (e.g., a written report). Careful planning up front can help you avoid many problems associated with delivering satisfactory results. To help minimize problems associated with execution of an independent study, each student must submit an Independent Study Application/Approval Form. This form includes a description of the independent study and requires the signature of the instructor, the student's advisor, and a department officer (generally the associate head of the department). The form can be obtained from Becky Stillwell.

Special Topics Course (CEE 398 and 498): Special topic courses provide a mechanism to easily introduce new classes into the curriculum. These courses are designated as "experimental courses" because they have not been through the required review process of permanent courses.

Some civil engineering disciplines rely on special topics courses to complete the course offerings in the category of advanced technical courses. These courses (see Appendix D of this chapter) will generally be approved by the Program Review Committee for the primary or secondary field in the area which offers the course, even though they do not appear on the list of recommended courses.

2.4 Data Science Certificate

CEE undergraduates can earn a CEE-focused [Certificate in Data Science and Computing](#) by taking a series of four courses that focus on data handling and processing; data analysis, including machine learning; computing; and data presentation. All are presented within the context of the CEE sub-disciplines.

Appendix A. Integrated Design Courses

An integrated design course is a course that has a design project as part of the course requirements. The following courses meet the conditions of an integrated design course.

CEE 401	Concrete Materials
CEE 415	Geometric Design of Roads
CEE 421	Construction Planning
CEE 449	Environmental Engineering Lab
CEE 453	Urban Hydrology and Hydraulics
CEE 465	Design of Structural Systems
CEE 484	Applied Soil Mechanics
CEE 493	Sustainable Design Eng Tech

Appendix B. Civil Engineering Courses with a Laboratory Component

CEE 300	Behavior of Materials
CEE 331	Fluid Dynamics in the Natural Built Environment
CEE 401	Concrete Materials
CEE 405	Asphalt Materials, I
CEE 449	Environmental Engineering Lab
CEE 458	Water Resources Field Methods
CEE 483	Soil Mechanics and Behaviors

Appendix C. Design Content of Civil and Environmental Engineering Courses

The design content of a course is a number representing the number of credit hours of the course that are directly associated with engineering design. The design content of each CEE course in the catalog are listed below.

The design content of a course is a number representing the number of credit hours of the course that are directly associated with engineering design. The design content of each CEE course in the catalog are listed below.

CEE 190	Project Based Introduction to CEE	0.50
CEE 201	Systems Engineering & Economics	1.50
CEE 202	Engineering Risk & Uncertainty	1.50
CEE 300	Behavior of Materials	1.00
CEE 310	Transportation Engineering	1.00
CEE 311	Engineering Surveying	1.20
CEE 320	Construction Engineering	1.50
CEE 330	Environmental Engineering	0.50
CEE 331	Fluid Dynamics in the Natural and Built Environment	0.00
CEE 340	Energy and Global Environment	1.00
CEE 350	Water Resources Engineering	1.30
CEE 360	Structural Engineering	0.50
CEE 380	Geotechnical Engineering	1.00
CEE 401	Concrete Materials	1.00
CEE 405	Asphalt Materials, I	2.00
CEE 406	Pavement Design, I	2.50
CEE 407	Airport Design	2.00
CEE 408	Railroad Transportation Engineering	1.00

CEE 409	Railroad Track Engineering	2.00
CEE 410	Railway Signaling and Control	1.00
CEE 411	Railroad Project Design & Constr	2.00
CEE 412	High-Speed Rail Engineering	1.00
CEE 415	Geometric Design of Roads	3.00
CEE 416	Traffic Capacity Analysis	1.50
CEE 417	Urban Transportation Planning	0.00
CEE 418	Public Transportation Systems	1.00
CEE 419	Transportation Economics	0.00
CEE 420	Construction Productivity	2.10
CEE 421	Construction Planning	2.50
CEE 422	Construction Cost Analysis	1.80
CEE 424	Sustainable Const Methods	1.00
CEE 430	Ecological Quality Engineering	1.00
CEE 432	Stream Ecology	1.00
CEE 433	Water Technology and Policy	0.50
CEE 434	Environmental Systems, I	2.00
CEE 435	Public Health Engineering	0.00
CEE 437	Water Quality Engineering	1.50
CEE 438	Science and Environmental Policy	0.25
CEE 440	Fate Cleanup Environ Pollutant	1.00
CEE 441	Air Pollution Sources, Transport, and Control	2.00
CEE 442	Env Eng Principles, Physical	0.50
CEE 443	Env Eng Principles, Chemical	0.00
CEE 444	Env Eng Principles, Biological	0.00
CEE 447	Atmospheric Chemistry	0.00
CEE 449	Environmental Engineering Lab	2.00
CEE 450	Surface Hydrology	0.75
CEE 451	Environmental Fluid Mechanics	0.60
CEE 452	Hydraulic Analysis and Design	2.50
CEE 453	Urban Hydrology and Hydraulics	3.00
CEE 457	Groundwater	0.25
CEE 458	Water Resources Field Methods	1.00
CEE 459	Ecohydraulics	0.80
CEE 460	Steel Structures, I	2.40
CEE 461	Reinforced Concrete, I	2.40
CEE 462	Steel Structures, II	2.40
CEE 463	Reinforced Concrete, II	2.25
CEE 465	Design of Structural Systems	3.00
CEE 467	Masonry Structures	2.40
CEE 468	Prestressed Concrete	2.40
CEE 469	Wood Structures	2.40
CEE 470	Structural Analysis	1.00
CEE 471	Structural Mechanics	0.30
CEE 472	Structural Dynamics	1.00
CEE 473	Wind Effects on Structures	0.00
CEE 474	Mechanics of Additive Manufacturing	0.75
CEE 483	Soil Mechanics and Behavior	1.50

CEE 484	Applied Soil Mechanics	2.50
CEE 490	Computer Methods	0.00
CEE 491	Decision and Risk Analysis	1.50
CEE 492	Data Science for Civil and Environmental Engineering	0.00
CEE 493	Sustainable Design Eng Tech	2.00
CEE 495	Professional Practice	0.00
CEE 497	Independent Study*	0.00
CEE 498	Special Topics*	0.00

3

Academic Program Plan

3.1 What is the Academic Program Plan?

The Academic Program Plan is a contract for the degree of Bachelor of Science in Civil Engineering. The Academic Program Plan can be found here: <https://cee.illinois.edu/academics/undergraduate-programs/undergrad-resources> An approved program plan is a necessary part of specifying a student's degree requirements specific to Civil Engineering. The Degree Audit, described in Section 3.5 below, is helpful in monitoring your progress toward meeting the other degree requirements.

3.2 Development and Review of the Academic Program Plan

The Academic Program Plan should be reviewed by your faculty advisor. It is not a valid document without the signature of your faculty advisor. Your plan will be reviewed by CEE advising staff and the Program Review Committee. All Academic Program Plans are subject to final approval by the Associate Head and Director of Undergraduate Studies of Civil and Environmental Engineering. The review process is generally completed in four weeks.

If you include a transfer course on your Academic Program Plan, use the rubric and course number of the course at the institution where you took the course (if the course transfers as an equivalent course at UIUC, then please use the UIUC course number on the program plan). On the reverse side of the Plan, give the title of the course, the name of the institution where the course was taken, and the semester in which it was taken. If you include a CEE 497 or CEE 498 course on your Academic Program Plan, include a brief description of the independent study or special topic along with the name of the faculty member who supervised the work or offered the course. To expedite approval of your Academic Program Plan, it is advisable to obtain approval of any transfer, CEE 497, or CEE 498 courses before you submit your plan (see Section 3.7).

A new program plan can be submitted at any time, including during the semester in which all degree requirements are completed. Late submissions could delay graduation. A new plan will be reviewed on its own merits independent of previous actions. For example, elements of the previously accepted plan (e.g., a certain science elective) will be accepted in the new plan only if they continue to have merit.

3.3 Submission of the Academic Program Plan

The Academic Program Plan must be submitted by your junior year in the first two weeks of the spring semester. For normal progress, this time corresponds with the second semester of the 3rd year of study. If the Academic Program Plan has not been received by the time indicated above, an advising hold may be placed, preventing registration for future semesters. The advising hold will be lifted upon receipt of the Academic Program Plan.

The Academic Program plan requires students to take a laboratory course and an integrated design course. The integrated design course must be selected from the primary area. Students must also meet a minimum

of 13 design hours between their core and advanced technical courses. These requirements must be met to graduate.

You should submit your Academic Program Plan (and any revisions of it), with your signature and the signature of your faculty advisor, to the Academic Advisor, in 1102 Newmark.

3.4 Monitoring and Assessment of Student Progress

The faculty advisor plays an important role in the development of a student's program of study, in monitoring the progress of the student, and in giving general advice on the role of the program in career development. The advising system in the Department of Civil and Environmental Engineering helps to assure that the educational objectives of the program are met to the best of the ability of each student.

3.5 Degree Audit

A degree audit is an unofficial audit of progress toward the degree that reflects courses completed and currently in progress.

University of Illinois students can view their degree audit through the [Degree Audit System](#). This report is an unofficial audit of your degree progress which includes in progress coursework. Watch for additional information and advisories specific to your college at the top of your degree audit: <http://registrar.illinois.edu/dars-audit>

3.6 Going Above and Beyond the Program Requirements

The graduation requirements outlined in Chapter 2 are the minimum requirements. The most common reason for going above and beyond course requirements is changing majors – certain courses you have completed may not count towards your new degree. The second most common reason is the desire to take more than the minimum number of technical courses.

If you plan to take an extra technical elective at the 400 level, do not list the extra course on your Academic Program Plan as a technical elective. If you list it, then it is part of your B.S. degree; that is the nature of the contract. If you decide to go to graduate school later, you will not be able to petition to have the course credit count towards your M.S. degree, because you already agreed that it would count toward your B.S. degree (and your degree was awarded based on that agreement). If you take an extra course **DO NOT** list it on your Academic Program Plan. Many 400-level CEE courses have two sections, 3hrs for undergraduates and 4hrs for graduate students. If you intend to use a 400-level CEE course towards your graduate degree in the future, please speak to the Academic Advisor or Assistant Director of Undergraduate Programs.

3.7 Independent Study and Special Topics Courses

A student may take an independent study (i.e., CEE 497) or a special topics course (i.e., CEE 498) in partial fulfillment of the degree requirements. Such a course can count as a technical elective in the primary or secondary field and is subject to the program review process. The section of the program plan called *Explanatory Notes and Comments* should give the title of the course, the instructor's name, and a brief description of the course. The syllabus for the course should be submitted as a supporting document.

The number design hours for CEE 497 and CEE 498 courses is zero unless the instructor specifically requests them on a case-by-case basis. The request must include the content of design due to a project or endeavors that demonstrate creativity and problem solving in the context of civil engineering. The Program Review Committee will review and approve the request and designated design hour.

4

Typical Eight Semester Schedule

There is some flexibility implicit in the sequencing of the courses you must take to complete the undergraduate curriculum in Civil Engineering. The order of your courses will be affected by remedial courses, advanced placement, transfer courses, prerequisite courses, and course availability. That said, it is very helpful to see the layout of a typical eight-semester program.

First Year	Hour	First Semester (17 hours)
	4	CEE 190—Project-Based Introduction to CEE ¹
	1	ENG 100—Engineering Lecture
	4	MATH 221—Calculus I ³
	3	CHEM 102—General Chemistry I
	1	CHEM 103—General Chemistry Lab I
	4	RHET 105—Principles of Composition ² (OR SE 101 – Engineering Graphics and Design)
	Hours	Second Semester (17 hours)
	3	CS 101—Intro Computing: Engrg & Science
	4	PHYS 211—Univ Physics, Mechanics
	3	MATH 231—Calculus II
	3	CHEM 104—General Chemistry II
	1	CHEM 105—General Chemistry Lab II
	3	SE 101—Engineering Graphics & Design ² (OR RHET 105 – Principles of Composition.)
Second Year	Hours	First Semester (17 hours)
	3	CEE 201—Systems Engrg & Economics
	4	PHYS 212—Univ Physics, Elec & Mag
	4	MATH 241—Calculus III
	3	TAM 211—Statics
	3	MATH 257—Linear Algebra w/Comp Appls
	Hours	Second Semester (17 hours)
	3	CEE 202—Engineering Risk & Uncertainty
	2	PHYS 213—Univ Physics, Thermal Physics
	3	TAM 212— Introductory Dynamics
	3	TAM 251— Introductory Solid Mechanics
	3	General Education Elective (Econ 102/103)
	3	Free Elective

	Hours	First Semester (16 hours)
	4	TAM 335—Introductory Fluid Mechanics ¹⁰
	3	Civil engineering core course
	3	Civil engineering core course
	3	Science elective ⁶
Third Year	3	General Education Elective

	Hours	Second Semester (15 or 16 hours)
	3 or 4	Civil engineering core courses ⁷ (Adv Comp)
	3	MATH 285—Intro Differential Equations ⁵
	3	Civil engineering core course
	3	Civil engineering core course
	3	General Education Elective

Fourth Year	Hours	First Semester (15 hours)
	0	CEE 495—Professional Practice ⁹
	3	Advanced technical electives ⁸
	3	Advanced technical electives ⁸
	3	Advanced technical electives ⁸
	3	General Education Elective
	3	Free Elective

	Hours	Second Semester (13 hours)
	3	Advanced technical electives ⁸
	3	Advanced technical electives ⁸
	3	Advanced technical electives ⁸
	4	Free Elective ¹¹

Footnotes

1. CEE 190 is offered in the fall semester.
2. First Year Students are half enrolled in RHET 105 in the fall and half in the spring of a given year. Students who are not enrolled for RHET 105 in the fall should take SE 101 during that term and vice versa in the spring.
3. MATH 220—Calculus may be substituted for MATH 221, with just four of the five credit hours applying toward the degree. MATH 220 is appropriate for students with no background at all in calculus.
4. MATH 415 (3 hours) can be substituted for MATH 257 (3 hours). MATH 415 provides a stronger background in linear algebra and can be used for the mathematics minor.
5. MATH 284 or MATH 286 (4 hours) are acceptable substitutes for Math 285 (3 hours).
6. The Science elective is selected in accord with recommendations for the chosen primary fields of study in civil engineering, as outlined in Chapter 5.
7. CEE 300 **OR** CEE 340 are the Advanced Composition courses for students in Civil Engineering.
8. Advanced technical electives are selected to correspond with chosen primary and secondary fields of study in civil engineering, as outlined in Chapter 5.
9. CEE 495 is available in the fall semester.
10. CEE 331 Fluid Dynamics in the Natural Built Environmental (4hrs) can be substituted for TAM 335.
11. Free Electives: Additional course work, subject to the [Grainger College of Engineering restrictions to Free Electives](#).

5

Advanced Technical Programs

As part of the requirements for the degree of B.S. in Civil Engineering, each student must complete courses in both a primary and secondary specialization. At least 12 hours must be taken in the primary field, and at least 6 hours must be taken in the secondary field.

The primary field must be one of the following disciplines of civil engineering: Construction Engineering and Management, Construction Materials Engineering, Environmental Engineering, Geotechnical Engineering, Structural Engineering, Transportation Engineering, Water Resources Engineering and Science, Energy-Water-Environment Sustainability, Societal Risk Management, and Sustainable and Resilient Infrastructure Systems. The secondary fields can be selected from one of these ten disciplines (different from the primary), or a student can select from another group of secondaries listed in this chapter. It is not advisable to have primary and secondary areas only in the CEE interdisciplinary programs of EWES, SRM, and SRIS. A student can also elect the General Option in lieu of primary and secondary fields. This section of the handbook gives, for each discipline, a general description of the area and the curricular requirements for a primary or a secondary in that field.

5.1 General Advice on Selecting a Primary and Secondary Field

After the basic decision to major in civil engineering, the next crucial decision is the program requirement of selecting a primary and secondary field of specialization. This decision affects the choice of core courses, the science elective, and the advanced technical courses. This choice affects over 30 hours of elective credit and involves up to 3 semesters of prerequisite dependencies. Hence, this decision should be made early in the third year of study. The Academic Program Plan must be submitted by your junior year in the first two weeks of the spring semester. For normal progress, this time corresponds with the second semester of the 3rd year of study (see Section 3.3).

There are many things that can be useful in deciding on your specialties—from childhood dreams to recent work experiences. While your experience in the core courses in the various areas may be helpful in making this decision, remember that those courses give only introductory knowledge to fields that harbor lifetimes of interesting experiences requiring knowledge far beyond what you can learn in the first course. Your faculty advisor or the Academic Advisor is probably your best resource for sorting out this important career decision.

5.2 Organization of the Material in this Chapter

Each page that follows contains a brief description of the field of study and the course requirements and recommendations for primary and secondary specializations in that field. There is also a flow chart giving the prerequisite structure of all the courses in that discipline emanating from the required and civil engineering core courses.

5.3 Construction Engineering and Management

Construction and Engineering and Management prepares students to manage design, construction and operation of sustainable buildings and infrastructure systems in the increasingly global construction industry. They analyze the labor, materials, and equipment for each job to determine the proper quantity of each and ensure availability at the appropriate time and place. Construction engineers use computers in planning, scheduling, estimating, production forecasting, fiscal control, and inventory tracking.

Primary in Construction Engineering and Management

Science Electives

Required: (Select one course from recommended list.)
 Recommended: ATMS 120, ATMS 303, ECE 205, FIN 221, GEOL 107, GEOL 118, GEOL 333, GEOL 380, ME 200, NPRE 201, SE 400, STAT 420, UP 205

Civil Engineering Core Courses

Required: CEE 300, CEE 320, CEE 360, CEE 380
 Recommended: None

Advanced Technical Courses

Required: CEE 420, *CEE 421, CEE 422 one of CEE 401, CEE 461, CEE 498 CEM, CEE 498 CS
 Recommended: CEE 460, CEE 469

***CEE 421 – Construction Planning is the required Integrated Design course**

Secondary in Construction Engineering and Management

Civil Engineering Core Courses

Required: CEE 320

Advanced Technical Courses

Required: CEE 421, one of (CEE 420, CEE 422)
 Recommended: None

Prerequisite structure for advanced courses in this field

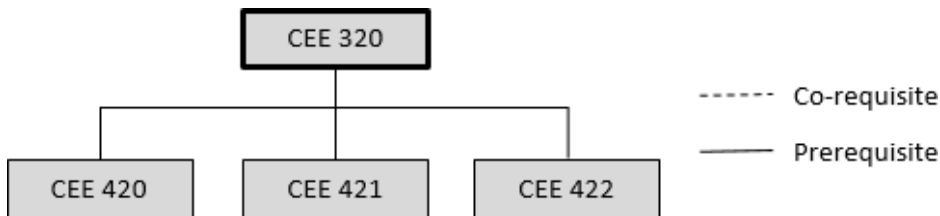

5.4 Construction Materials Engineering

Civil engineers are often responsible for specifying, designing, and manufacturing the materials with which they build their structures. Concrete, field welds, and asphalt pavement are examples of materials that are produced or processes that are carried out by the civil engineer in the field. Studies in materials engineering are intended to help civil engineers use materials more intelligently in their design of buildings and other constructed facilities. Topics such as the physics and chemistry of metals, ceramics, and polymers are the bases of this area and lead to the consideration of the response of structural steel, asphalt, and concrete to loads and hostile environments. Engineers with a background in materials engineering often work with consulting companies that specialize in forensic work on failed structures and companies concerned with repair and rehabilitation of the infrastructure.

Primary in Construction Materials Engineering

Science Electives

Required: (Select one course from recommended list.)
Recommended: ESE 140 or GEOL 107

Civil Engineering Core Courses

Required: CEE 300, CEE 310, CEE 360
Recommended: CEE 320, CEE 340, CEE 380

Advanced Technical Courses

Required: *CEE 401 and CEE 405
Recommended: CEE 406, CEE 460, CEE 461, CEE 469, CEE 483, MSE 401, MSE 402, MSE 450, MSE 489, ME 430, TAM 428

*CEE 401 – Concrete Materials is the required Integrated Design course

Secondary in Construction Materials Engineering

Civil Engineering Core Courses

Required: CEE 300

Advanced Technical Courses

Required: Two from the recommended list
Recommended: CEE 401, CEE 405, CEE 406

Prerequisite structure for advanced courses in this field

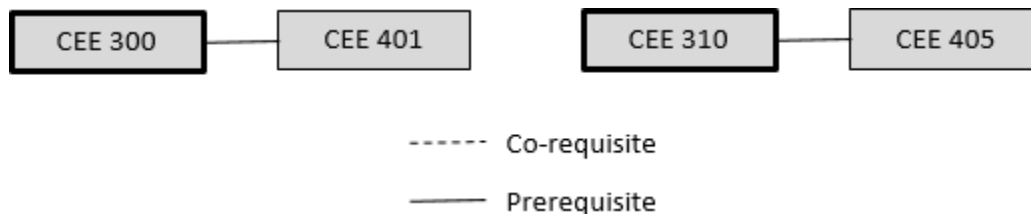

5.5 Environmental Engineering

Environmental engineers have taken an increasingly important role in activities of the world in recent years, because of the problems related to air, land, and water contamination. Environmental engineers provide treatment facilities that render industrial and human wastes free from contaminants. They design, construct, and operate systems that purify water for drinking, industrial, and recreational uses. They also develop and implement air purification devices and models that describe the transport, and removal of contaminants in the atmosphere. Solid and hazardous waste management protocols are also developed and implemented by environmental engineers. Many environmental engineers develop plans and conduct research to solve problems related to our rapidly changing technological society and expanding human population.

Primary in Environmental Engineering

Science Electives

Required: (Select one course from recommended list.)
 Recommended: ATMS 120, CHEM 222, CHEM 232, CS 357, GEOL 107, GEOL 118, MCB 300, ME 200, MSE 401, STAT 420,

Civil Engineering Core Courses

Required: CEE 330
 Recommended: CEE 340, CEE 350, CEE 380

Advanced Technical Course

Required: At least one of (CEE 437, CEE 440, CEE 441)
 Recommended: CEE 430, CEE 434, CEE 435, CEE 438, CEE 442, CEE 443, CEE 444, CEE 447, *CEE 449, CEE 452, CEE 453, CEE 457, CEE 493

***CEE 449 – Environmental Engineering Lab is the required Integrated Design course**

Secondary in Environmental Engineering

Civil Engineering Core Courses

Required: CEE 330

Advanced Technical Courses

Required: Two from the recommended list
 Recommended: CEE 430, CEE 434, CEE 435, CEE 437, CEE 438, CEE 440, CEE 441, CEE 442, CEE 443, CEE 444, CEE 447, CEE 449

Prerequisite structure for advanced courses in this field

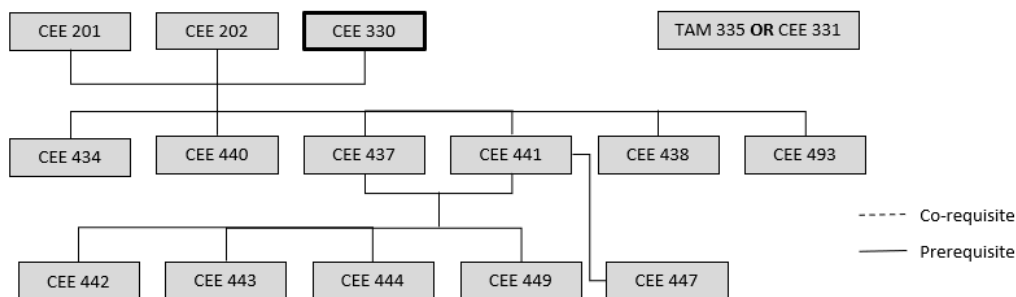

5.6 Geotechnical Engineering

Geotechnical engineers deal with soil and rock as engineering materials. These engineers design foundations for all types of structures, earth and rock-filled dams, tunnels, braced excavations, and earth-retaining structures. They also investigate and design stabilization measures for landslides and other ground failures, such as those that occur in earthquakes. Many geotechnical engineers are involved in geo-environmental issues such as solid waste disposal, contaminant transport through soil, and site remediation. A geotechnical engineer should have knowledge of geology and structural engineering.

Primary in Geotechnical Engineering

Science Electives

Required: GEOL 107
Recommended: None

Civil Engineering Core Courses

Required: CEE 360, CEE 380
Recommended: CEE 300, CEE 310, CEE 320, CEE 330, CEE 350

Advanced Technical Courses

Required: CEE 483 and ***CEE 484 (4hr)**
Recommended: CEE 457, CEE 460, CEE 461, CEE 463, CEE 498 GES, CEE 498 EG, CEE 498 OSF

***CEE 484 – Applied Soil Mechanics is the required Integrated Design course**

Secondary in Geotechnical Engineering

Civil Engineering Core Courses

Required: CEE 380

Advanced Technical Courses

Required: CEE 483
Recommended: CEE 484, CEE 498 GES, CEE 498 EG, CEE 498 OSF

Prerequisite structure for advanced courses in this field

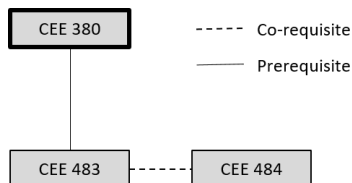

5.7 Structural Engineering

Structural engineering involves the analysis, design, and construction of buildings, dams, bridges, and other types of facilities. A structural engineer designs economical structures that satisfy requirements of safety, utility, and durability; oversees the building of constructed facilities; and investigates the performance of structures that fail to perform as expected. The tools of the structural engineer include physical testing, mathematical modeling, and computer simulation. The structural engineer uses these tools to make decisions that aid in the creation, maintenance, or demolition of constructed facilities. The largest of structures, such as the Golden Gate Bridge, Hoover Dam, and Eiffel Tower, stand as monuments to the engineering achievements of humankind. The smallest of structures, such as thin films that contain computer circuitry, make possible many devices in our technologically sophisticated society.

Primary in Structural Engineering

Science Electives

Required: (Select one course from recommended list.)
 Recommended: CS 357, ECE 205, GEOL 107, GEOL 118, ME 200

Civil Engineering Core Courses

Required: CEE 300, CEE 360, CEE 380
 Recommended: CEE 320

Advanced Technical Courses

Required: CEE 460, CEE 461, *CEE 465, CEE 470
 Recommended: None

***CEE 465 – Design of Structural Systems is the required Integrated Design course**

Secondary in Structural Engineering

Civil Engineering Core Courses

Required: CEE 360

Advanced Technical Courses

Required: CEE 460, CEE 461
 Recommended: None

Prerequisite structure for advanced courses in this

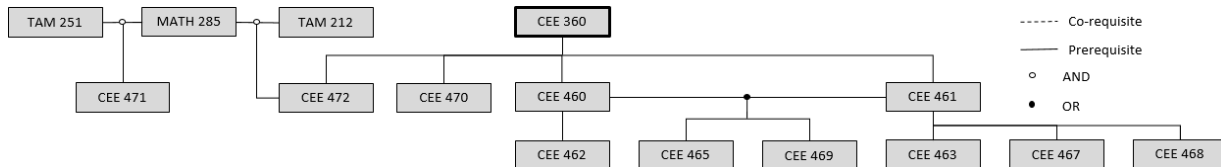

5.8 Transportation Engineering

Transportation engineers design, build, operate and maintain all types of facilities for railroads, automobiles, airplanes, and ships. They deal with the physical infrastructure of our transportation system—highways, ports, airports, and other facilities. They are involved in controlling traffic and in developing better transportation systems. Transportation engineers must understand the many factors that affect the long-term performance of the infrastructure from climatic factors imposed on it to the dynamics of the vehicles that use it. Transportation engineers are concerned with the development and operation of our multi-modal transportation system to meet the constantly changing social, economic, geographical, and political needs of society.

Primary in Transportation Engineering

Science Electives

Required: (Select one course from recommended list.)
 Recommended: ATMS 120, CS 357, ECE 205, GEOL 107, GEOL 118, ME 200, ME 340, MSE 401, SE 320, STAT 420

Civil Engineering Core Courses

Required: CEE 300, CEE 310
 Recommended: CEE 320, CEE 330, CEE 350, CEE 360, CEE 380

Advanced Technical Courses

Required: You must select one course from each of the three Areas and one from the recommended list. The Transportation Program Leader or Associate Head should approve a deviation from this plan.

*Area 1 — Facilities: CEE 405, CEE 406
 *Area 2 — Systems: CEE 407, *CEE 415, CEE 416, CEE 418
 *Area 3 — Railroad: CEE 408, CEE 409, CEE 410, CEE 411, CEE 412
 Recommended: CEE 401, CEE 405, CEE 406, CEE 408, CEE 409, CEE 410, CEE 411, CEE 412, CEE 415, CEE 416, CEE 417, CEE 418, CEE 419

***CEE 415 Geometric Design of Roads is the required Integrated Design course**

Secondary in Transportation Engineering

Civil Engineering Core Courses

Required: CEE 310

Advanced Technical Courses

Required: You must select two courses, each from a different Area*
 *Area 1 — Facilities: CEE 405, CEE 406
 *Area 2 — Systems: CEE 407, CEE 415, CEE 416, CEE 418
 *Area 3 — Railroad: CEE 408, CEE 409, CEE 410, CEE 411, CEE 412
 Recommended: None

Prerequisite structure for advanced courses in this field

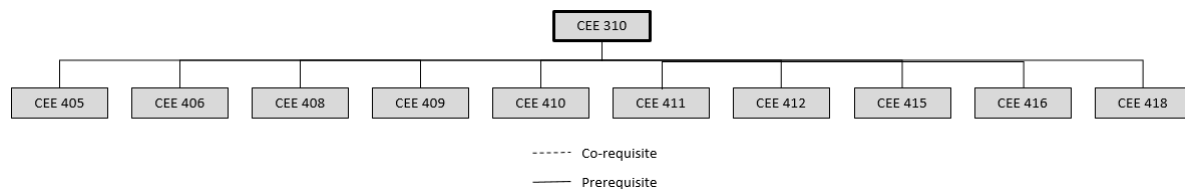

5.8 Water Resources Engineering and Science

Water Resources Engineering and Science deals with surface and ground water used for human consumption, energy, food, transportation, and recreation, as well as mitigation of floods and other water-related hazards. This area comprises the fields of hydrology, hydraulics, and water resources planning. Hydrology is the study of water in the natural environment. Hydraulics studies how to design infrastructure to manage water flow and storage. Water resources planning concerns how to manage water efficiently and economically under hydrologic, hydraulic, economic, and societal constraints. Engineers in this discipline are responsible for the planning, design, operation, and management of facilities for domestic, municipal, industrial and agricultural water supply, drainage, control, and utilization. Such facilities include river channel-dam-reservoir systems for flood control, hydropower, navigation, water supply, and recreation; water distribution networks, sewer systems and culverts for urban water supply and drainage; injection/extraction well systems for remediation of contaminated ground water; and erosion and sediment control structures. Water Resources Engineers are also involved in the planning, operation, and management of ground water, watersheds, and wetlands, as well as the hydrologic environment's response to human impacts and climatic changes.

Primary in Water Resources Engineering and Science

Science Electives

Required: (Select one course from recommended list.)
 Recommended: ATMS 120, CS 357, GEOL 107, GEOL 118, ME 200

Civil Engineering Core Courses

Required: CEE 350
 Recommended: CEE 300, CEE 310, CEE 320, CEE 330, CEE 340, CEE 360, CEE 380

Advanced Technical Courses

Required: CEE 452 or *CEE 453
 Recommended: CEE 432, CEE 433, CEE 434, CEE 437, CEE 450, CEE 451, CEE 452, CEE 453, CEE 457, CEE 458, CEE 459

***CEE 453 Urban Hydrology and Hydraulics is the required Integrated Design course**

Secondary in Water Resources Engineering and Science

Civil Engineering Core Courses

Required: CEE 350

Advanced Technical Courses

Required: Two from the recommended list
 Recommended: CEE 432, CEE 433, CEE 434, CEE 450, CEE 451, CEE 452, CEE 453, CEE 457, CEE 458, CEE 459

Prerequisite structure for advanced courses in this field

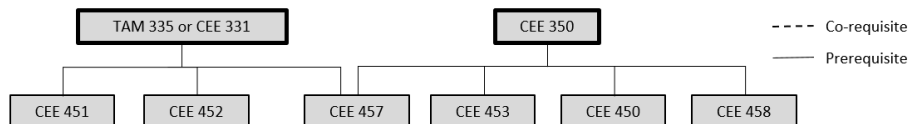

5.9 Energy-Water-Environment Sustainability

Civil and environmental engineers are increasingly being called upon to develop solutions to society’s growing energy needs and its intersection with water and the environment. Developing sustainable engineered processes and systems for the exploration, production, delivery, and use of energy requires knowledge and skills that cut across traditional areas of civil engineering as well as related areas of engineering and science. This specialization is intended for students interested in a cross-disciplinary civil and environmental engineering education emphasizing scientific principles, engineered processes, and systems analyses necessary to address challenges at the nexus between energy production and use, water and air quality, and environmental sustainability. Engineers with this specialization will be ready to work in a variety of capacities, including performing energy/water footprint analyses of engineered processes and infrastructure, designing more energy- and water-efficient green building systems, developing more sustainable processes and systems for fossil fuel and renewable energy exploration, production and delivery, and incorporating sustainability principles and life cycle analyses within the civil engineering design process.

Primary in Energy-Water-Environment Sustainability

Science Electives

Required: CHBE 321 or ME 200

Civil Engineering Core Courses

Required: CEE 340
 Recommended: CEE 330, CEE 350

Advanced Technical Courses

Required: CEE 493 (and select three courses from the recommended list)
 Recommended: ABE 436, CEE 433, CEE 435, CEE 434, CEE 437, CEE 441, CEE 449, CEE 450, CEE 452, CEE 453, CEE 457, CEE 459, CEE 473, CEE 492, CEE 498 GES, ME 400, NPRE 402, NPRE 475

Secondary in Energy-Water-Environment Sustainability

Civil Engineering Core Courses

Required: CEE 340

Advanced Technical Courses

Required: CEE 493 (and select one course from the recommended list)
 Recommended: ABE 436, CEE 433, CEE 434, CEE 435, CEE 437, CEE 441, CEE 449, CEE 450, CEE 452, CEE 453, CEE 457, CEE 459, CEE 473, CEE 492, CEE 498 GES, ME 400, NPRE 402, NPRE 475

Prerequisite structure for advanced courses in this field

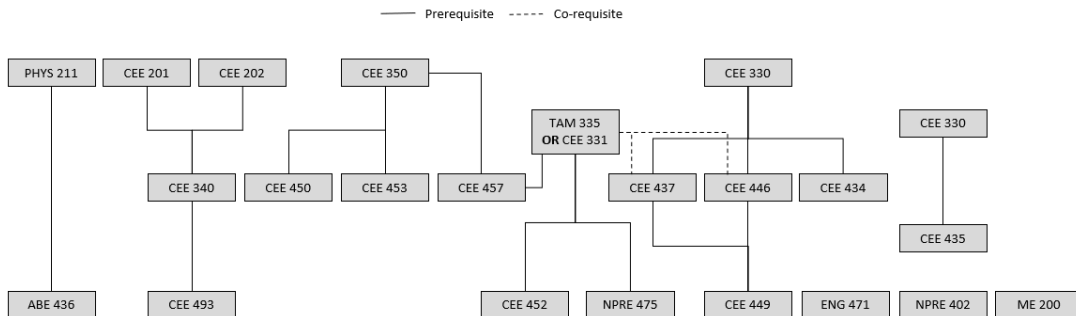

5.10 Societal Risk and Hazard Mitigation

The overarching goal of the SRHM program is to promote a secure and safe society. To achieve this aim, the program concentrates on risk determination, risk evaluation and risk management for natural and man-made hazards, and disaster response and recovery. The program is cross-disciplinary in nature; students are exposed to content in reliability, risk and life cycle analysis; decision making under uncertainty; performance assessment of deteriorating systems; the ethical, economic and political dimensions of risk management; the legal elements of regulatory mechanisms; risk perception and cognitive biases; risk communication; and post-disaster response and recovery.

This primary prepares students to work in a variety of positions from traditional CEE design firms to insurance companies, management consulting firms, and government agencies. For those students interested in graduate education, this primary prepares them to pursue a higher education in a variety of fields within, and outside of, CEE.

Primary in Societal Risk Management and Hazard Mitigation

Science Electives

Recommended: FIN 230, GEOL 118, LAW 301, NRES 287, STAT 420

Civil Engineering Core Courses

Required: CEE 340

Recommended: CEE 300, CEE 310, CEE 320, CEE 330, CEE 350, CEE 360, CEE 380

Advanced Technical Courses

Required: CEE 491 (and select three courses from the recommended list)

Recommended: CEE 406, CEE 416, CEE 417, CEE 437, CEE 440, CEE 449, CEE 460, CEE 461, CEE 465, CEE 472, CEE 473, IE 410, NPRE 442, SE 450, STAT 425, STAT 429, STAT 430

Secondary in Societal Risk Management and Hazard Mitigation

Civil Engineering Core Courses

Required: None

Advanced Technical Courses

Required: CEE 491 (and select one course from the recommended list above)

Prerequisite structure for advanced courses in this

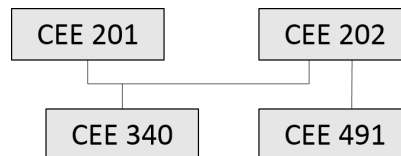

5.12 Sustainable and Resilient Infrastructure Systems

These primary addresses emerging approaches to infrastructure systems focusing on resiliency and sustainability of interconnected infrastructure – for example, structural, geotechnical and water interactions in urban environments. This discipline provides integrated multidisciplinary and systems-based education within civil and environmental engineering. The capability for synthesis across areas of CEE is particularly suited for careers in general CEE design firms, government agencies and higher education.

Primary in Sustainable and Resilient Infrastructure Systems

Science Electives

Recommended: ATMS 120, CS 357, ENSU 300, ESE 140, ESE 320, ESE 482, FIN 221, GGIS 103, NPRE 201, NRES 439, SE 320, STAT 420, UP 406

Civil Engineering Core Courses

Required: CEE 340

Recommended: CEE 300, CEE 310, CEE 320, CEE 330, CEE 350, CEE 380

Advanced Technical Courses

Required: CEE 491 (and select three courses from the recommended list)

Recommended: ABE 436, CEE 401, CEE 406, CEE 408, CEE 409, CEE 416, CEE 417, CEE 418, CEE 421, CEE 434, CEE 453, CEE 458, CEE 465, CEE 493, MSE 489, UP 466, UP 480

Secondary in Sustainable and Resilient Infrastructure Systems

The CEE Secondary in Sustainability is designed for students who want to integrate sustainability into one of the existing primaries, providing technical depth in a core CEE area with an understanding of how sustainability issues affect CEE practice and research. Some examples (not all-inclusive) of CEE-related sustainability topics are given below, along with corresponding primaries that students may want to select with the sustainability secondary:

- Construction material recycling and reuse – Construction Management
- Green construction materials – Construction Materials Engineering
- Water reuse and energy reclamation from waste – Environmental Engineering
- Waste power generation in landfills – Geotechnical Engineering
- Storm water capture and best management practices – Water Resources Engineering
- Green building design – Structural Engineering
- Permeable pavements and green transportation system design – Transportation

Civil Engineering Core Courses

Required: CEE 340

Recommended: CEE 300, CEE 310, CEE 320, CEE 330, CEE 350, CEE 380

Advanced Technical Courses

Required: CEE 491 (and select one course from the recommended list above)

5.11 Additional Civil Engineering Secondaries

Secondary Area in Global Context

Students interested in the global context are encouraged to pursue the International Minor in Engineering (<http://www.engr.illinois.edu/international>) and to select Liberal Education requirements, humanities and social science electives, and free electives that address global culture, international regulations, history, geography, economics, politics, sociology, language, or literature. The courses that are particularly recommended to provide context on global issues relevant to CEE include GGIS 384, GLBL 480, UP 185, and UP 423.

Science Electives

Recommended: CPSC 116, ESE 140, ESE 320

Civil Engineering Core Courses

Recommended: CEE 330, CEE 340, or CEE 350

Advanced Technical Courses

Required: Students must take at least: (1) 3 credit hours that provide knowledge and skills needed to effectively address global issues and (2) 3 credit hours that enable them to design holistically by coupling expertise in their specialty with an understanding of system-level interactions and sustainability issues that affect their designs.

Knowledge and Skills Needed to Effectively Address Global Issues (3 hrs)

Recommended: ACE 451, ATMS 421, CEE 438, CEE 441, CEE 447, CEE 450, ECON 420, ESE 482

Global CEE Design (3 hrs)

Recommended: CEE 408, CEE 417, CEE 437, CEE 449, CEE 465

Secondary Area in CEE Multidisciplinary

The frontiers of CEE are becoming increasingly multidisciplinary, spanning sub-fields of CEE as well as other engineering and non-engineering fields. The purpose of this secondary is to provide guidelines for students with interests that do not align with an existing secondary option to develop custom multidisciplinary programs. All custom programs must be approved by Assistant Director of Undergraduate Programs and the Associate Head for Undergraduate Programs.

Science Electives

Recommended: Any recommended Science elective from the existing CEE primaries and secondaries

Civil Engineering Core Courses

Recommended: Core courses relevant to the student's interests

Advanced Technical Courses

These courses represent the technical heart of the CEE undergraduate program and provide many required design hours. Students should consider the following guidelines in selecting advanced technical courses for a custom secondary:

- Courses selected should provide background technical knowledge and skills needed to address CEE-related problems and processes. Students may propose any engineering and non-engineering courses (minimum of 6 hours) at the 300- or 400-levels if the total design hours of a student's program plan meet the ABET requirement of 16 hours. Students should provide a brief justification for the selection of their courses in the "Explanatory Notes and Comments" section of the academic program plan.
- Students may fulfill a portion of this requirement through an independent design project (CEE 497) supervised by a CEE faculty member.
- Design hours can be assigned for CEE 497 projects or engineering courses outside of CEE but cannot be assigned for non-engineering courses. The Associate Head for Undergraduate Program will determine assignment of design hours in consultation with the course instructor.

5.12 Other Non-CEE Secondary Areas

It's possible to select a secondary field of study that does not align directly with one of the main disciplines of civil engineering. In general, these secondary fields should have a connection to at least one of the civil engineering disciplines or to a career outcome that would benefit from an education in civil engineering. Novel programs are subject to review by the Program Review Committee and must be approved by the Associate Head of Civil and Environmental Engineering in charge of undergraduate studies. For secondary fields outside CEE one must carefully examine the prerequisites for the courses listed.

Atmospheric Science

Primary field: Environmental Engineering

Civil Engineering Core Courses

Required: CEE 330

Advanced Technical Courses

Recommended: ATMS 302, ATMS 410, ATMS 411, ATMS 421, CEE 441, CEE 447

Chemistry

Primary field: Environmental Engineering

Civil Engineering Core Courses

Required: CEE 330

Advanced Technical Courses

Recommended: CHEM 232, CHEM 315, CHEM 332, CHEM 420, CHEM 440

Chemical Engineering

Primary field: Environmental Engineering

Civil Engineering Core Courses

Required: CEE 330, CEE 350

Advanced Technical Courses

Recommended: CHBE 321, CHBE 421, CHBE 422, CHBE 424

Microbiology

Primary field: Environmental Engineering

Civil Engineering Core Courses

Required: CEE 330

Advanced Technical Courses

Recommended: CEE 444, MCB 301, MCB 431, MCB 450

Toxicology

Primary field: Environmental Engineering

Civil Engineering Core Courses

Required: CEE 330

Advanced Technical Courses

Recommended: CHEM 332, ENVS 431, ENVS 480, MCB 450

5.13 The General Civil Engineering Option

The General Option was created to recognize that there are career opportunities in Civil and Environmental Engineering for which an extensive understanding of all aspects of Civil Engineering has merit over specialization. Some civil and environmental engineers solve problems, which require interaction with other engineering and non-engineering disciplines. These problems can, and often do, involve multiple teams with diverse expertise and background. Students choosing the General Civil Engineering option are encouraged to discuss with their faculty advisor and/or CEE advising staff.

Requirements of the General Option

Science Electives

Required: One from recommended list
Recommended: GEOL 107, CHEM 222, CHEM 232, ME 200, STAT 400

Civil Engineering Core Courses

Required: CEE 300, CEE 310, CEE 320, CEE 330, CEE 340, CEE 350, CEE 360, CEE 380 (7 of 8 required)

Advanced Technical Courses

Required: Option I: Pick no more than one course from each area to satisfy the requirement that the sum of the core and advanced courses be at least 34 hours.
Option II: Pick two courses from one area and no more than one course from each of the remaining areas until you reach 34 hours.

Acceptable advanced technical courses:

Construction	CEE 420, CEE 421, CEE 422
Environmental	CEE 437, CEE 440, CEE 446
Geotechnical	CEE 483, CEE 484
Materials	CEE 401
Structures	CEE 460, CEE 461
Transportation	CEE 405, CEE 406, CEE, 408, CEE 409, CEE 410, CEE 411, CEE 412, CEE 415, CEE 416, CEE 417, CEE 418
Water Resources	CEE 452, CEE 453

Notes:

- (1) The General Option requires seven of the eight civil engineering core courses, as opposed to just five in the ordinary program. Hence, nearly all the basic civil engineering disciplines are covered at the core level.
- (2) All the acceptable advanced technical courses are 3-hour courses, except for CEE 401, CEE 415, CEE 453, and CEE 483, which are 4-hour courses. Hence, in most cases this option requires 4 or 5 advanced technical courses.
- (3) The acceptable advanced technical courses are listed in numerical order within each area. There is no implication that the first course listed is more appropriate than the second, third, etc.

6

Civil Engineering Courses

Catalog Descriptions

This section of the handbook contains the course descriptions for 100, 200, 300, and 400 level courses taught through the Civil and Environmental Engineering department. The courses are listed in numerical order. The rubric CEE is implied. Each entry has a brief description, the prerequisites, and the number of hours of credit for the course. These entries should correspond exactly to the UIUC Course Catalog.

- 190. Project-Based Introduction to CEE.** Allows freshmen to explore topics in Civil and Environmental Engineering through a project-based learning format. The course also develops competencies in critical skills such as technical writing in CEE, data management and computation, and design thinking in a collaborative team environment. 4 hours.
- 198. Special Topics.** Structured presentations of new and developing areas of knowledge in civil engineering offered by the faculty to augment the formal courses available. Prerequisite: Individually identified for each offering under this course number. 1 to 4 hours.
- 201. Systems Engrg & Economics.** Introduction to the formulation and solution of civil engineering problems. Major topics are engineering economy, mathematical modeling, and optimization. Techniques, including classical optimization, linear and nonlinear programming, network theory, critical path methods, simulation, decision theory, and dynamic programming are applied to a variety of civil engineering problems Prerequisite: MATH 231; CS 101; credit or concurrent registration in MATH 257 or MATH 415. 3 hours.
- 202. Engineering Risk & Uncertainty.** Identification and modeling of non-deterministic problems in civil engineering design and decision making. Development of stochastic concepts and simulation models and their relevance to real design and decision problems in various areas of civil engineering. Prerequisite's CS 101, Credit or concurrent registration in MATH 241.
- 300. Behavior of Materials.** Same as TAM 324. Mechanical behavior of engineering materials, including metals, ceramics polymers, concrete, wood, bitumen, and asphaltic concretes; explanations of macroscopic behavior in terms of phenomena at the microscopic level. Lecture/lab format. Prerequisite: Completion of Composition I; CHEM 104; TAM 251. 4 hours.
- 310. Transportation Engineering.** An introduction to the design, planning, operation, management, and maintenance of transportation systems; integrated multi-modal transportation systems (highways, air, rail, etc.); layout of highways, airports, and railroads with traffic flow models, capacity analysis, and safety.

- Design of facilities and systems with life cycle costing procedures and criteria for optimization. Prerequisite: TAM 251; credit or concurrent registration in CEE 202. 3 hours.
- 320. Construction Engineering.** Introduction to the construction processes: contracting and bonding, planning and scheduling, estimating and project control, productivity models, and construction econometrics. Prerequisite: CEE 201; credit or concurrent registration in CS 101 and CEE 202. 3 hours.
- 330. Environmental Engineering.** Considers the sources, characteristics, transport, and effects of air and water contaminants; biological, chemical, and physical processes in water; atmospheric structure and composition; unit operations for air and water quality control; solid waste management; and environmental quality standards. Prerequisite: CHEM 104 or CHEM 204. 3 hours.
- 331. Fluid Dynamics in the Natural and Built Environment** Fundamentals of fluid motion and transport processes in the natural, managed, and built environment. Focus on physical understanding of the behavior of fluids for applications in natural and engineering challenges. Hydrostatics, dimensional analysis, equations of incompressible fluid motion, open channel flow, flow in porous media, groundwater, pipe flow, boundary layers, drag and lift, turbulence, fluids and energy, are covered within a global context to emphasize the role of fluid dynamics on the environment within the framework of the hydrologic cycle in nature and in the built environment. Credit is not given for CEE 331 and either TAM 335 or ME 310. Prerequisite: TAM 211. Credit or concurrent registration in TAM 212.
- 340. Energy and Global Environment.** Introduction to evaluating multiple impacts of engineering decisions. Topics include mass and chemical balances; effects of engineered systems on local and global environment, health, and risk; economic, consumer, and social considerations; provision of conventional and renewable energy; and future projections. Design projects emphasize making appropriate decisions by quantifying total impact and evaluating social environment. Prerequisite: Completion of Composition I; PHYS 211; PHYS 213; CEE 201 or IE 310; CEE 202, IE 300, or STAT 200; or permission of instructor. 3 hours.
- 350. Water Resources Engineering.** Quantitative aspects of water in the earth's environment and its engineering implications, including design and analysis of systems directly concerned with use and control of water; quantitative introduction to hydrology, hydraulic engineering, and water resources planning. Prerequisite: CEE 202; credit or concurrent registration in CEE 201. 3 hours.
- 360. Structural Engineering.** Basic topics in the analysis, behavior and design of trusses and framed structures under static loads; topics include member forces in trusses, shear and moment diagrams, deflections, simple applications of the force method and slope-deflection; introduction to computer applications. Prerequisite: TAM 251. 3 hours.
- 380. Geotechnical Engineering.** Introduction to geotechnical engineering. Classification of soils, compaction in the laboratory and in the field, soil exploration, boring and sampling, permeability of soils, one-dimensional settlement analyses, strength of soil, introduction to foundations. Prerequisite: TAM 251. 3 hours.
- 398. Special Topics.** Structured presentations of new and developing areas of knowledge in civil engineering offered by the faculty to augment the formal courses available. Prerequisite: Individually identified for each offering under this course number. 1 to 4 hours.
- 401. Concrete Materials.** Examines the influence of constituent materials (cements, aggregates and admixtures) on the properties of fresh and hardened concrete; mix design handling and placement of concrete; and behavior of concrete under various types of loading and environment; test methods. Laboratory practice is an integral part of the course. Prerequisite: CEE 300. 4 hours.
- 405. Asphalt Materials, I.** Properties and control testing of bituminous materials, aggregates for bituminous mixtures, and analysis and design of asphalt concrete and liquid asphalt cold mixtures; structural properties of bituminous mixes; surface treatment design; and recycling of mixtures. Prerequisite: CEE 310. 3 hours.
- 406. Pavement Design, I.** Analysis, behavior, performance, and structural design of pavements for highways

and airfields; topics include climate factors, rehabilitation, life cycle design economics, and traffic loadings. Prerequisite: CEE 310. 3 hours.

407. **Airport Design.** Basic principles of airport facilities design to include aircraft operational characteristics, noise, site selection, land use compatibility, operational area, ground access and egress, terminals, ground service areas, airport capacity, and special types of airports. 3 hours.
408. **Railroad Transportation Engineering.** Principles and analysis of railroad transportation efficiency, economics, energy, and engineering; effect on production and markets. Introduction to railroad infrastructure; locomotive and rolling stock design, function, and operation. Calculation of train speed, power, and acceleration requirements; introduction to railway traffic control and signaling. Quantitative analytical tools for railroad transportation decision-making and optimization. Field trip to observe railroad infrastructure, equipment and operations. Prerequisite: CEE 310. 3 hours
409. **Railroad Track Engineering.** In depth examination of railroad track engineering concepts including track component and system design, constructions, evaluation, maintenance, load distribution, and wheel/rail interaction. Design and analysis tools for railroad track engineering and maintenance. Field trip to observe railroad track system and components. Prerequisite: CEE 310. 3 hours.
410. **Railway Signaling and Control.** Railway traffic and control and signaling systems; train performance and scheduling tools; analysis of temporal and spatial separation of trains for safety and efficiency; train movement authority and operating rules; track circuit and wireless train position monitoring technology; interlocking design; railroad capacity modeling tools and economic analysis of traffic control system design, optimization and selection. Field trip to observe signal system infrastructure and railway traffic operations control center. Prerequisite: CEE 310. 3 hours.
411. **Railroad Project Design & Constr.** Critical elements in the development and planning of railroad construction projects; project economic justification; route alternative analysis procedures; cost estimation; site civil design; computer-aided track design; surveying; construction management; construction procedures for typical railroad projects. Design project covering typical railroad capital construction projects. Field trip to observe the construction of a railroad capital project. Prerequisite: CEE 310. 3 hours.
412. **High Speed Rail Engineering.** Development, engineering, design, and construction of high-speed rail (HSR) passenger transport systems with particular emphasis on the unique engineering elements of HSR technology. Key elements of HSR systems and subsystems include core systems (trains, power, signal, communication, and control), track system and civil infrastructure (earthwork, bridges, viaducts and tunnels). Also covered are basic design and construction of HSR stations and rolling stock maintenance facilities. 3 hours
415. **Geometric Design of Roads.** Analysis of factors in developing a highway transportation facility; traffic estimates and assignment; problems of highway geometrics and design standards; planning and location principles; intersection design factors; street systems and terminal facilities; programming improvements; drainage design; structural design of surface; concepts of highway management and finance; and highway maintenance planning. Prerequisite: CEE 310. 4 hours.
416. **Traffic Capacity Analysis.** Study of fundamentals of traffic engineering; analysis of traffic stream characteristics; capacity of urban and rural highways; design and analysis of traffic signals and intersections; traffic control; traffic impact studies; and traffic accidents. Prerequisite: CEE 310. 3 hours
417. **Urban Transportation Planning.** Same as UP 430. Role of transportation in urban development and planning; characteristics of urban-person transportation systems and methods of analysis and forecasting of urban-person transportation demand; transportation systems management and capital improvement programming; and emphasis on the needs and activities of metropolitan planning organizations. 4 hours
418. **Public Transportation Systems.** Transit systems basics, demand issues, design standards, economic and sustainability implications. Transit service planning for shuttle, corridor, and network systems, hybrid

- hierarchical systems, paratransit, and demand-responsive services. Management of transit systems, fleet operations, and crew scheduling. Operational issues, vehicle movement, headway and schedule control. Prerequisite: CEE 310 or equivalent. 3 hours
- 419. Transportation Economics** Uses analytical and numerical models of decision-making to analyze phenomena such as traffic congestion, apply vocabulary and techniques from economics, and to explore ways to provide and regulate transportation. Students will write Python code for optimization, simulation, visualization, and choice modelling. Engineers will gain from learning to think rigorously about the fact that the humans in the systems they design make their own choices. 4 undergraduate hours. 4 graduate hours. Prerequisite: CEE 310.
- 420. Construction Productivity.** Introduction of the application of scientific principles to the measurement and forecasting of productivity in construction engineering. Conceptual and mathematical formulation of labor, equipment, and material factors affecting productivity. Prerequisite: CEE 320. 3 hours.
- 421. Construction Planning.** Project definition; scheduling and control models; material, labor and equipment allocation; optimal schedules; project organization; documentation and reporting systems; and management and control. Prerequisite: CEE 320. 3 hours.
- 422. Construction Cost Analysis.** Introduction to the application of scientific principles to costs and estimates of costs in construction engineering; concepts and statistical measurements of the factors involved in direct costs, general overhead costs, cost markups and profits; and the fundamentals of cost recording for construction cost accounts and cost controls. Prerequisite: CEE 320. 3 hours.
- 430. Ecological Quality Engineering.** Characteristics of rivers and lakes which affect the management of domestic and industrial wastewaters; chemical hazards assessment, surveillance and biomonitoring, and review of regulations governing effluents. Prerequisite: CEE 330. 2 hours.
- 432. Stream Ecology.** Description of physical, chemical, and biological characteristics in streams and rivers including an integrated treatment of the environmental factors affecting the composition and distribution of biota; emphasizes the application of ecological engineering principles in aquatic ecosystem protection and management. Same as IB 450. 3 hours.
- 433. Water Technology and Policy.** This course will cover technical and social concepts of water and wastewater treatment; water resources; water law, policy, and economics; and water in integrated systems. Emphasis will be on the intersection between engineering and policy. Communication is an important element of this course: engineers will learn to "speak" policy via writing assignments, multimedia presentation, and briefings. Course activities include lecture, discussion, presentations, and field trips Prerequisite: CEE 340 or CEE 350. 3 hours
- 434. Environmental Systems, I.** Introduction to the concepts and applications of environmental systems analysis. Application of mathematical programming and modeling to the design, planning and management of engineered environmental systems, regional environmental systems, and environmental policy. Economic analysis, including benefit-cost analysis and management strategies. Concepts of tradeoff, non-inferior sets, single and multi-objective optimization. Practical application to case studies to convey an understanding of the complexity and data collection challenges of actual design practice. Prerequisite: CEE 201 and CEE 330. 3 hours
- 435. Public Health Engineering** Aimed at building a next generation of engineers who are able to incorporate the principles of public health in all engineering designs. The course starts with the basic principles of epidemiology (types, methods, models and limitations). Next, the course covers various modes of environmental toxicity and the models to represent these modes. The course then covers infectious diseases, various models to represent their spread, the effect of environmental factors and the role of public health in breaking the chain of infection. The course also discusses environmental, social and behavioral factors in public health (e.g. environmental tobacco smoke including E-vaping) in the prevalence of chronic diseases. Finally, we cover the topics on public health risk assessment and management. In every aspect of the topic, the role of engineering in solving the problems of public health

- is explored and emphasized. 3 undergraduate hours. 4 graduate hours. Prerequisite: CEE 330.
437. **Water Quality Engineering.** Fundamental theory underlying the unit processes utilized in the treatment of water for domestic and industrial usage, and in the treatment of domestic and industrial wastewaters. Prerequisite: CEE 330; credit or concurrent registration in CEE 331 or TAM 335. 3 hours.
438. **Science and Environmental Policy.** Environmental treaties, the role of science and scientists in managing the national and global environment, effective science communication, scientific assessments, and the use of quantitative tools to inform policy decisions. Prerequisite: CEE 202 or IE 300 or STAT 400, or equivalent introductory probability and statistics course. Senior and Graduate students. 3 hours.
440. **Fate Cleanup Environ Pollutant.** Investigation of the regulatory and technical issues affecting solid and hazardous waste management, with an emphasis on the principles governing the transport, fate, and remediation of solid and hazardous waste in the subsurface, including advection, dispersion, sorption, interphase mass transfer, and transformation reactions. Prerequisite: CEE 330. 4 hours.
441. **Air Pollution Sources, Transport and Control** A design approach to air pollution fate and control for the protection of human health and welfare. Air pollution transport and deposition. Gaussian plume, chemical mass balance models. Gaseous and particulate air pollutant physical and chemical properties and control. Evaluation of air pollutant emission control strategies based on cost and regulatory requirements for compliance with regulatory ambient air quality standards. 4 undergraduate hours. 4 graduate hours. Prerequisite: CEE 331 or equivalent; CEE 202 or equivalent. Credit or concurrent enrollment in ATMS 302 or equivalent.
442. **Env Eng Principles, Physical.** Analysis of the physical principles which form the basis of many water and air quality-control operations; sedimentation, filtration, inertial separations, flocculation, mixing and principles of reactor design. Prerequisite: CEE 437. 4 hours.
443. **Env Eng Principles, Chemical.** Application of principles of chemical equilibrium and chemical kinetics to air and water quality. Chemistry topics are thermodynamics, kinetics, acid/base chemistry, complexation, precipitation, dissolution, and oxidation/reduction. Many applications are also presented. Prerequisite: CEE 330. 4 hours.
444. **Env Eng Principles, Biological.** Application of principles of biochemistry and microbiology to air and water quality, wastes, and their engineering management; biological mediated changes in water and in domestic and industrial wastewater. Prerequisite: CEE 443. 3 hours.
447. **Atmospheric Chemistry.** The course will present current knowledge of the biochemical cycles of atmospheric trace gases, their interactions on global and regional scales, and their significance for chemistry in the atmosphere. The important fundamental concepts that are central to understanding air pollutants, e.g., the formation of aerosols and the transformation and removal of species in the atmosphere, will be introduced. Same as ATMS 420. Prerequisite: CHEM 104; either CEE 330 or ATMS 401. 3 hours.
449. **Environmental Engineering Lab.** Combination of lecture and laboratory designed to provide exposure to the use of traditional analysis tools and techniques in analysis, control, and design of natural and engineered environmental systems including air, water, wastewater, solid and hazardous waste, and ecological systems. Prerequisite: CEE 330. 3 hours.
450. **Surface Hydrology.** Study of descriptive and quantitative hydrology dealing with the distribution, circulation, and storage of water on the earth's surface; discusses principles of hydrologic processes and presents methods of analysis and their applications to engineering and environmental problems. Prerequisite: CEE 350. 3 hours.
451. **Environmental Fluid Mechanics.** Incompressible fluid mechanics with particular emphasis on topics in analysis and applications in civil engineering areas; primary topics include principles of continuity, momentum and energy, kinematics of flow and stream functions, potential flow, laminar motion, turbulence, and boundary-layer theory. Prerequisite: CEE 331 or TAM 335. 3 hours.

452. **Hydraulic Analysis and Design.** Hydraulic analysis and design of engineering systems: closed conduits and pipe networks; hydraulic structures, including spillways, stilling basins, and embankment seepage; selection and installation of hydraulic machinery. Prerequisite: CEE 331 or TAM 335. 3 hours.
453. **Urban Hydrology and Hydraulics.** Hydraulic analysis and design of urban, highway, airport, and small rural watershed drainage problems; discussion of overland and drainage channel flows; hydraulics of storm-drain systems and culverts; determination of design flow; runoff for highways, airports, and urban areas; design of drainage gutters, channels, sewer networks, and culverts. Prerequisite: CEE 350. 4 hours.
457. **Groundwater.** Physical properties of groundwater and aquifers, principles and fundamental equations of porous media flow and mass transport, well hydraulics and pumping test analysis, role of groundwater in the hydrologic cycle, groundwater quality and contamination. Prerequisite: CEE 350 and CEE 331 or TAM 335, or consent of instructor. 3 hours.
458. **Water Resources Field Methods.** Scientific principles of measurement technologies and protocols used for water-resources measurements and experimental design of field-scale water-resources and environmental studies. Planning field studies; instruments and protocols for surface-water, groundwater, and water-quality sampling; description of data quality. One-half-day laboratory field trips to streamflow monitoring stations and groundwater monitoring wells nearby. Prerequisite: CEE 350. 4 hours
459. **Ecohydraulics** Interactions between hydraulic, ecological, and geomorphic processes in river environments at a wide range of both spatial and temporal scales. Draws upon and synthesize fundamental concepts from biology, ecology, fluid mechanics and morphodynamics, to apply them to truly interdisciplinary problems. Such an approach, coupled with hands-on experience involving planning, conducting, and analyzing hands-on experiments at the Ven Te Chow Hydrosystems Laboratory and field surveys on local natural waters will provide the students with a broad perspective on the interconnections between physical and ecological systems. Students will apply their knowledge of fundamental processes to assess complex problems involving monitoring, management, conservation, and restoration of ecosystems. 4 undergraduate hours. 4 graduate hours.
460. **Steel Structures, I.** Introduction to the design of metal structures; behavior of members and their connections; and theoretical, experimental, and practical bases for proportioning members and their connections. Prerequisite: CEE 360. 3 hours.
461. **Reinforced Concrete, I.** Study of the strength, behavior, and design of reinforced concrete members subjected to moments, shear, and axial forces, extensive discussion of the influence of the material properties on behavior. Prerequisite: CEE 360. 3 hours.
462. **Steel Structures, II.** Metal members under combined loads; connections, welded and bolted; moment-resistant connections; plate girders, conventional behavior, and tension field action. Prerequisite: CEE 460. 3 hours.
463. **Reinforced Concrete, II.** Study of the strength, behavior, and design of indeterminate reinforced concrete structures, with primary emphasis on slab systems; emphasis on the strength of slabs and on the available methods of design of slabs spanning in two directions, with or without supporting beams. Prerequisite: CEE 461. 3 hours.
465. **Design of Structural Systems.** The whole structural design process includes definition of functional requirements, selection of structural scheme, formulation of design criteria, preliminary and computer-aided proportioning, and analysis of response, cost, and value. Prerequisite: Credit in either CEE 460 or CEE 461 and concurrent enrollment in the other. 3 hours.
467. **Masonry Structures.** Introduction to analysis, design and construction of masonry structures. Mechanical properties of clay and concrete masonry units, mortar, and grout. Compressive, tensile, flexural, and shear behavior of masonry structural components. Strength and behavior of unreinforced bearing walls. Detailed design of reinforced masonry beams, columns, structural walls with and without openings, and complete

- lateral-force resisting building systems. Prerequisite: CEE 461. 3 hours.
- 468. Prestressed Concrete.** Study of strength, behavior, and design of prestressed reinforced concrete members and structures, with primary emphasis on pretensioned, precast construction; emphasis on the necessary coordination between design and construction techniques in prestressing. Prerequisite: CEE 461. 3 hours.
- 469. Wood Structures.** Mechanical properties of wood, stress grades and working stresses; effects of strength-reducing characteristics, moisture content, and duration of loading and causes of wood deterioration; glued-laminated timber and plywood; behavior and design of connections, beams, and beam-columns; design of buildings and bridges; other structural applications: trusses, rigid frames, arches, and pole-type buildings; and prismatic plates and hyperbolic paraboloids. Prerequisite: CEE 460 or CEE 461. 3 hours.
- 470. Structural Analysis.** Direct stiffness method of structural analysis; fundamentals and algorithms; numerical analysis of plane trusses, grids and frames; virtual work and energy principles; introduction to the finite element method for plane stress and plane strain. Prerequisite: CEE 360. 4 hours.
- 471. Structural Mechanics.** Beams under lateral load and thrust; beams on elastic foundations; virtual work and energy principles; principles of solid mechanics, stress and strain in three dimensions; static stability theory; torsion; computational methods. Prerequisite: MATH 285 and TAM 251. 3 hours.
- 472. Structural Dynamics, I.** Analysis of the dynamic response of structures and structural components to transient loads and foundation excitation; single-degree-of-freedom and multi-degree-of-freedom systems; response spectrum concepts; simple inelastic structural systems; and introduction to systems with distributed mass and flexibility. Prerequisite: TAM 212, MATH 385, and CEE 360. 3 hours.
- 473. Wind Effect on Structures** This course treats fundamental aspects of wind engineering – defined here as the salient characteristics of the wind and its effects on the built and natural environment. Students are expected to understand the behavior of wind relevant to wind engineering, the mechanisms for induced loading from wind, and associated structural responses. Specific topics include prediction of wind speeds for structural design, the atmospheric boundary layer, bluff-body aerodynamics, dynamic analysis, use of wind tunnels, wind loading on low-rise and high-rise buildings, wind loading on bridges, windstorm damage and risk. As the wind is a stochastic process, simulation of large data sets of wind speed, wind-induced pressure, and structural responses are required. Treatment of wind engineering topics for structural design for wind in codes and standards such as those in ASCE 7 are discussed. Fieldwork is required as part of the course. 4 hours. Prerequisite: CEE 202 or STAT 400, CEE 331 or TAM 335, and CEE 360.
- 474. Mechanics of Additive Manufacturing** Introduction to process physics for additive manufacturing (AM); Basic materials science for AM, cement-based materials, polymer-based materials. Fundamental mechanics principles involved in layered additive manufacturing; Mathematical models for AM, transport phenomena and flow modeling, curing and property evolution, residual stresses and fatigue effects; Introduction to the Role of Robotics, Machine Learning and Data Science in modern AM. 3 undergraduate hours. 4 graduate hours. Prerequisite: MSE 280, or CEE 300, or ME 330, or CEE 471.
- 483. Soil Mechanics and Behavior.** Composition and structure of soil; water flow and hydraulic properties; stress in soil; compressibility behavior and properties of soils; consolidation and settlement analysis; shear strength of soils; compaction and unsaturated soils; experimental measurements. Prerequisite: CEE 380. 4 hours.
- 484. Applied Soil Mechanics.** Application of soil mechanics to earth pressures and retaining walls, stability of slopes, foundations for structures, excavations; construction considerations; instrumentation. Co-requisite: CEE 483. 3 or 4 hours.
- 490. Computer Methods** Computer methods and their programming for solving common types of differential equations arising in civil and environmental engineering (hyperbolic, parabolic, and elliptic equations, with emphasis on prototypical cases, such as the convection-diffusion equation, as well as Laplace's / Poisson's equation). Exposure to state-of-the-art open-source numerical methods libraries. The course enables students in civil and environmental engineering to develop high-performance and high-purpose codes in

these open-source frameworks for their research problems in an efficient way. 3 undergraduate hours. 4 graduate hours. Prerequisite: CEE 360 and CEE 331 or TAM 335.

- 491. Decision and Risk Analysis.** Development of modern statistical decision theory and risk analysis, and application of these concepts in civil engineering design and decision making; Bayesian statistical decision theory, decision tree, utility concepts, and multi-objective decision problems; modeling and analysis of uncertainties, practical risk evaluation, and formulation of risk-based design criteria, risk benefit trade-offs, and optimal decisions. Prerequisite: CEE 202. 3 hours.
- 492. Data Science for Civil and Environmental Engineering** Students will learn to leverage data to study civil and environmental engineering problems, identify patterns, and make actionable insights. This course includes training in computational thinking and exploratory data analysis; data processing techniques including singular value decomposition, principal component analysis, and Fourier and wavelet transforms; and machine learning techniques including k-means, classification trees, neural networks, and neural differential equations. Students are required to bring a laptop computer to class. 3 undergraduate hours. 4 graduate hours. Prerequisite: CS 101; CEE 202; and CEE 300, CEE 330, or CEE 360.
- 493. Sustainable Design Eng Tech.** Quantitative sustainable design (QSD) and how to navigate engineering decision-making. Economic (life cycle costing, techno-economic assessment) and environmental (life cycle assessment, LCA) sustainability assessments, and how to link these tools to design decisions under uncertainty. Design of engineered technologies individually and in teams, with special attention to water infrastructure and bioenergy production. Semester-long design project that includes components from two of the following three CEE sub-disciplines: environmental, hydraulic, geotechnical. Prerequisite: CEE 340. 4 hours.
- 495. Professional Practice.** Series of lectures by outstanding authorities on the practice of civil engineering and its relations to economics, sociology, and other fields of human endeavor. 0 undergraduate hours. Prerequisite: Junior standing. 0 hours.
- 497. Independent Study.** Individual investigations or studies of any phase of civil engineering selected by the student and approved by the department. Prerequisite: Senior or graduate standing; Consent of instructor. 1 to 16 hours.
- 498. Special Topics.** Structured presentations of new and developing areas of knowledge in civil engineering offered by the faculty to augment the formal courses available. 1 to 4 hours.

6.1 Semester Course Offerings

CEE courses are available in the semesters shown in the table below. This information is for planning purposes and is subject to change. Students should always depend on the university class schedule for reliable information when registering for upcoming semesters.

CEE Course	TITLE	FALL	SPRG	FA & SP	Varies
190	Project-Based Introduction to CEE	X			
198	Special Topics				X
201	Systems Engineering & Economics			X	
202	Engineering Risk & Uncertainty			X	
300	Behavior of Materials			X	
310	Transportation Engineering			X	
320	Construction Engineering			X	
330	Environmental Engineering			X	
331	Fluid Dynamics in the Natural Built Environment	X			
340	Energy and Global Environment	X			
350	Water Resources Engineering			X	
360	Structural Engineering			X	
380	Geotechnical Engineering			X	
398	Special Topics				X
401	Concrete Materials	X			
405	Asphalt Materials, I	X			
406	Pavement Design, I	X			
407	Airport Design		X		
408	Railroad Transportation Engineering	X			
409	Railroad Track Engineering	X			

CEE Course	TITLE	FALL	SPRG	FA & SP	Varies
410	Railroad Signaling and Control		X		
411	Railroad Project Design & Const		X		
412	High-Speed Rail Engineering	X			
415	Geometric Design of Roads		X		
416	Traffic Capacity Analysis	X			
417	Urban Transportation Planning				X
418	Public Transportation Systems		X		
419	Transportation Economics		X		
420	Construction Productivity		X		
421	Construction Planning			X	
422	Construction Cost Analysis	X			
430	Ecological Quality Engineering				X
432	Stream Ecology				X
433	Water Technology and Policy	X			
434	Environmental Systems I	X			
435	Public Health Engineering				X
437	Water Quality Engineering			X	
438	Science & Environmental Policy		X		
440	Fate Cleanup Environ Pollutant		X		
441	Air Pollution Sources, Transport & Control	X			
442	Env Eng Principles, Physical	X			
443	Env Eng Principles, Chemical	X			
444	Env Eng Principles, Biological		X		

CEE Course	TITLE	FALL	SPRG	FA & SP	Varies
447	Atmospheric Chemistry				X
449	Environmental Engineering Lab		X		
450	Surface Hydrology	X			
451	Environmental Fluid Mechanics	X			
452	Hydraulic Analysis and Design		X		
453	Urban Hydrology and Hydraulics		X		
457	Groundwater	X			
458	Water Resources Field Methods	X			
459	Ecohydraulics				X
460	Steel Structures, I			X	
461	Reinforced Concrete, I			X	
462	Steel Structures, II		X		
463	Reinforced Concrete, II	X			
465	Design of Structural Systems			X	
467	Masonry Structures				X
468	Prestressed Concrete		X		
469	Wood Structures				X
470	Structural Analysis			X	
471	Structural Mechanics	X			
472	Structural Dynamics, I	X			
473	Wind Effects on Structures	X			
474	Mechanics of Additive Manufacturing			X	
483	Soil Mechanics and Behavior			X	

CEE Course	TITLE	FALL	SPRG	FA & SP	Varies
484	Applied Soil Mechanics		X		
490	Computer Methods		X		
491	Decision and Risk Analysis				X
492	Data Science for CEE	X			
493	Sustainable Design Eng Tech	X			
495	Professional Practice	X			
497	Independent Study			X	
498	Special Topics			X	

Department of Civil and Environmental Engineering

Academic Program Plan

The **Academic Program Plan** is a contract for the degree of *Bachelor of Science in Civil Engineering* at the University of Illinois at Urbana-Champaign. This plan covers the technical elective portion of your degree requirements. You must also complete all required courses, general education requirements, humanities and social science electives, and free electives. Courses that appear on this plan must be selected according to the program requirements specified in the *Civil Engineering Undergraduate Handbook*. To elect the General Option, indicate General Option as the primary field and leave secondary field blank. A revised program can be proposed at any time by submitting a new Academic Program Plan for approval. **The Academic Program Plan must be completed in ink.**

Science Elective (3 hour Minimum)

Select according to requirements and recommendations of the chosen primary or secondary fields.

Civil Engineering Technical Courses (Core Courses + Advanced Courses = 34 hours minimum)

Core Courses

Select from CEE 300, CEE 310, CEE 320, CEE 330, CEE 340, CEE 350, CEE 360, and CEE 380.

Notes: Traditional program with primary and secondary fields requires five core courses (at least 15 hours). The General Option requires seven core courses. Primary and secondary fields and the General Option have specific course requirements and recommendations. See program Guidelines in the *Undergraduate Handbook*.

Advanced Courses

Program must include at least 12 hours from the primary field and 6 hours from the secondary field. For requirements of the General Option see *Undergraduate Handbook*. Design content of program must exceed 13 hours for all courses listed on this plan (note that 3 hours of design credit are associated with CEE 201 and CEE 202 to give a total of 16 hours). **At least one integrated design course from the primary area must be included on the program plan.**

Explanatory Notes and Comments

A section for explanatory notes and comments is provided on the reverse side. Note any transfer courses by course number, title, and institution.

Required Signatures

Student Date

Faculty Advisor Date

Program Review Committee Date

Associate Head of Civil and Environmental Engineering Date

Student's Name (Please type or print.) Net ID

Faculty Advisor's Name (Please type or print.)

UIN Degree Date

Primary Field

Secondary Field

Course	Credit Hrs	Design Hrs
Subtotals		

Subtotals		

Subtotals		

(Design hours can be found on pages 24 & 25 of the UG Handbook)

Summary Program Requirements

Please enter information in all boxes.

Total CEE technical credit
(Core + Advanced Courses)

Total Design credit
(Sum of all design hours above,
plus 3 hours from 201 & 202)

Integrated design course
(Give course number.)

Laboratory course
(Give course number.)

Explanatory Notes and Comments (to be filled out by student)

This section should be used to justify a program that is not pre-approved in the *Undergraduate Handbook*.

For a CEE 497 or CEE 498 course included in the program give instructor, title, date and a brief description of the topics covered.

Advisor Comments (to be filled out by the faculty advisor)

This section should provide supporting remarks either for a program that is not pre-approved in the *Undergraduate Handbook* or for a request to deviate from standard program requirements (e.g., design content requirements).

Advisor Comments (to be filled out by the faculty advisor)

This section should provide supporting remarks either for a program that is not pre-approved in the *Undergraduate Handbook* or for a request to deviate from standard program requirements (e.g., design content requirements).

Department of Civil and Environmental Engineering

University of Illinois Urbana-Champaign
1114 Newmark Civil Engineering Laboratory
205 N. Mathews Ave.
Urbana, IL 61801

cee.illinois.edu