



THE UNIVERSITY  
*of*  
**WISCONSIN**  
MADISON

# An Introduction to a Career in Medical Physics

Career Seminar

Department of Physics

University of Illinois at Urbana-Champaign

October 24, 2014

Dustin W. Wooten, PhD

[dwooten@pet.mgh.harvard.edu](mailto:dwooten@pet.mgh.harvard.edu)



MASSACHUSETTS  
GENERAL HOSPITAL



HARVARD  
MEDICAL SCHOOL

# I'll attempt to address

- What is medical physics?
- What does a medical physicist do?
- What are the clinical aspects of medical physics?
- What is the career path to becoming a medical physicist?
- What technologies does a medical physicist work with?
- What areas of research are medical physicists involved in?
- What research have I been involved in?

# What exactly is medical physics?

- Best described as the application of physics concepts, theories, and principles to medicine or healthcare
- Responsible for the technical foundations of radiology, radiation oncology, and nuclear medicine
- Built on foundation of physics, but with distinct body of knowledge and scholarship
- Distinct from biophysics
- Incorporates both theoretical and experimental methods, but inherently an applied discipline

# What does a medical physicist do?

- Medical physicists are in general concerned with:
  - clinical service and consultation
  - research and development
  - teaching
  - policy
- Generally focus on a combination
- Identify what areas of medical physics you would like to be involved in

# Career in medical physics

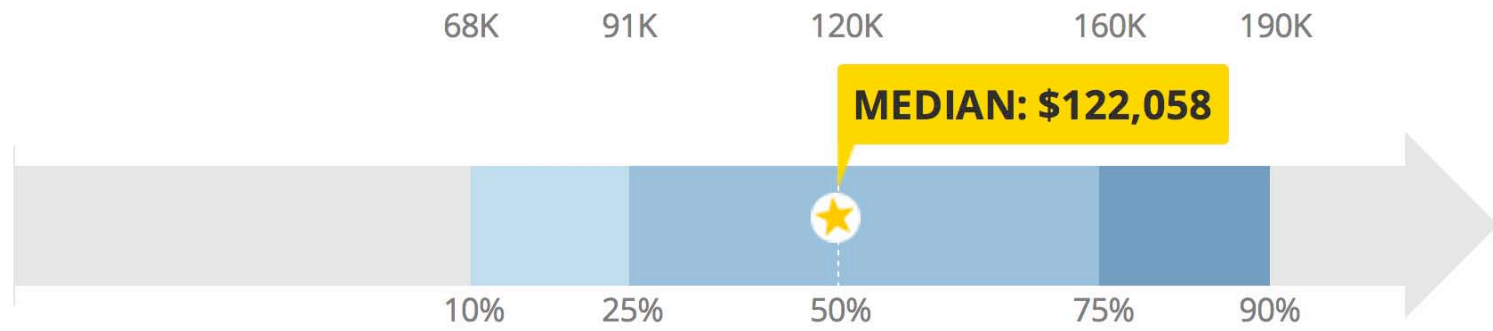

- The majority of Medical Physicists claim high levels of job satisfaction
- Average medical physicists salary above 6 figures (~\$122k)
- The range in pay spans from \$63,616 to \$188,107 per year
- Career duration is the biggest factor affecting pay for this group, followed by geography
- Medical benefits are awarded to the greater part, and most earn dental coverage

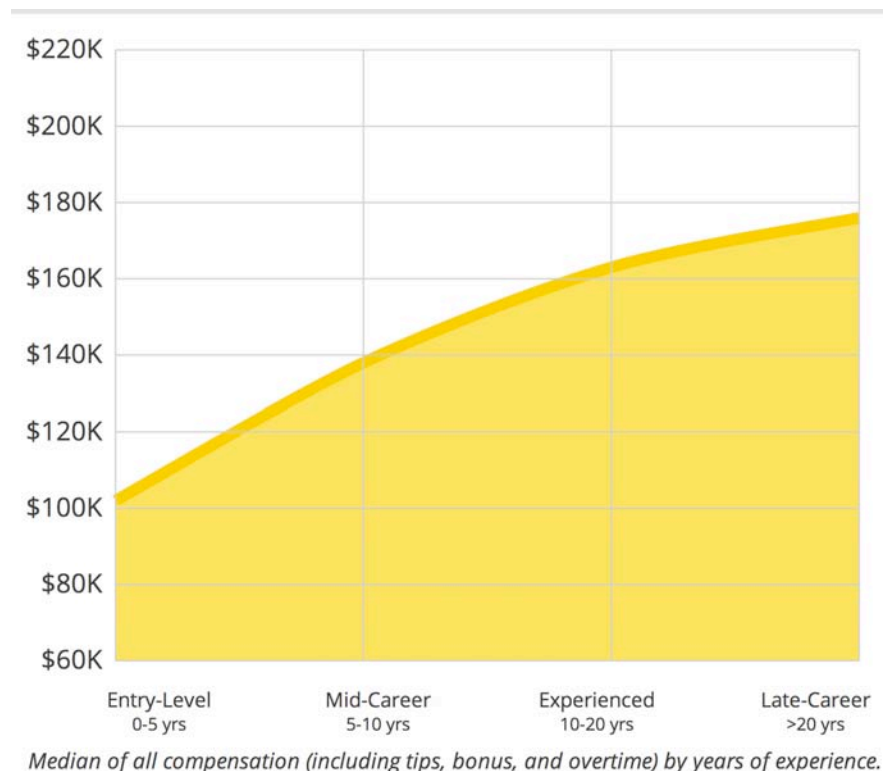

# Clinical Medical Physics

# What is required for a career in clinical medical physics?



- A bachelor's degree in physics is recommended
- Required completion (master's level or higher) at a Commission on Accreditation of Medical Physics Education Programs (aka CAMPEP) approved graduate program in medical physics
  - Covers mandatory classes in dosimetry, health physics, radiobiology, radiotherapy, medical imaging, etc.
  - Programs typically involve work in the clinic and lab

# Current CAMPEP approved medical physics programs

☐

Institution	Initial Accreditation	Institution	Initial Accreditation
University of Wisconsin †	1988	Carleton University†	2010
Wayne State University	1988	Georgia Institute of Technology	2010
University of Texas HSC - Houston	1989	San Diego State University	2010
McGill University	1993	SUNY Stony Brook University†	2010
University of California - Los Angeles †	1994	Vanderbilt University School of Medicine **	2010
University of Texas HSC - San Antonio†	1997	Virginia Commonwealth University	2010
University of Kentucky Medical Center	1998	Western University†	2010
University of Florida	2001	Cleveland State University - Cleveland Clinic	2011
University of Alberta - Cross Cancer Institute	2002	Oregon State University †	2011
University of British Columbia	2004	Universite Laval	2011
University of Calgary - Tom Baker Cancer Centre	2005	University of Missouri	2011
University of Oklahoma HSC	2005	University of Nevada Las Vegas†	2011
East Carolina University†	2006	University of Pennsylvania	2011
Louisiana State University	2006	Purdue University/Indiana University	2012
Duke University Medical Center †	2008	Seoul National University†	2012
University of Chicago	2008	University of Arizona	2012
University of Manitoba - CancerCare Manitoba†	2008	University of Massachusetts Lowell	2012
Columbia University	2009	Oklahoma State University†	2013
University at Buffalo (SUNY) School of Med	2009	Ryerson University†	2013
University of Cincinnati	2009	University of Miami	2013
University of New Mexico	2009	University of Minnesota	2013
University of Toledo Medical Center	2009	Florida Atlantic University	2014
University of Victoria - BC Cancer Agency	2009		



# Board certification is required for clinical medical physics practice

- Certification is through the American Board of Radiology
- Areas of board certification:
  - Therapeutic Medical Physics
  - Imaging Medical Physics
  - Nuclear Medical Physics
  - Medical Health Physics
- Criteria for board certification
  - Pass part 1: general and clinical examinations
  - Pass part 2: specific to individual field
  - Pass oral examination
- Part 1 is general and is specific to medical physics graduate coursework
- Part 2 and the oral exam are specific to knowledge and experience gained through clinical experience in postdoctoral fellowships or residency programs
- Oral examination given by a 5 member board who are experts in their respected fields of medical physics



# Medical physicist work in the clinic alongside medical doctors, nurses, and technicians.

- Heavily involved in working with specific patients in both diagnosis and treatment
- Medical physicist's often consult with physicians
- Work in the clinic is heavily oriented in uses of radiation for diagnostics and therapy:
  - Imaging
  - Radiation oncology and radiation therapy
- The medical physicist is called upon to contribute clinical and scientific advice and resources to solve the numerous and diverse physical problems that arise continually in many specialized medical areas
- A main role includes making sure diagnostic and therapy devices are operating correctly
- Services include assurance of equipment performance, quality control of imaging systems, design of radiation facilities, and control of radiation hazards (health physics and radiation safety).

# In medical imaging:

- Medical physicist perform quality assurance to verify scanners are operating correctly
  - X-ray, CT, MRI, SPECT, PET, etc.
  - Scanning phantoms for validation of image quality
  - Verify dosing (e.g., CT)
- Nuclear medicine
  - collaborating with physicians in the use of radiotracers which measure physiological processes such as measurement of metabolism, blood flow, and cellular proliferation.
  - check dose calibrators



MacFarlane, C. R. ACR Accreditation of Nuclear Medicine and PET Imaging Departments. *J. Nucl. Med. Technol.* **2006**, *34*, 18–24.



# X-ray imaging and computed tomography (CT)

- 1895 – Röntgen first announces his discovery of X-rays for imaging
- 1972 – Hounsfield announces his work on CT to generate attenuation maps
- Fluoroscopy

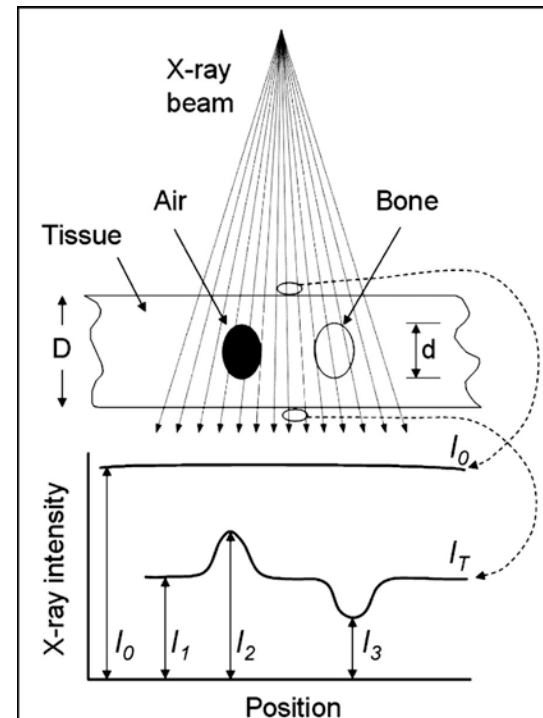

1. Seibert, J. A.; Boone, J. M.. Journal of nuclear medicine technology 2005, 33, 3–18.

The strength in CT lies in its ability to image density

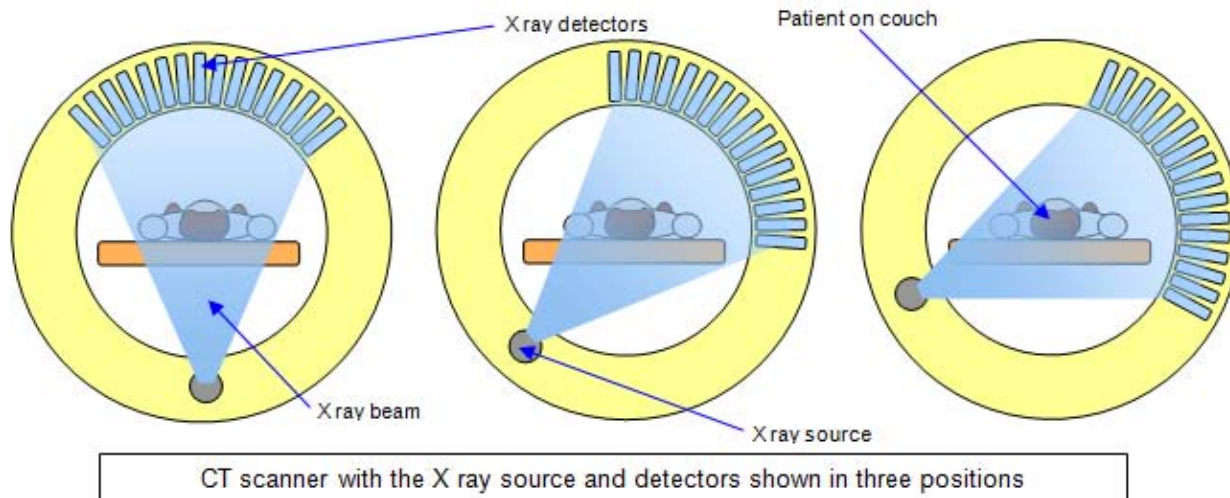

<http://www.schoolphysics.co.uk/>



<http://science.howstuffworks.com/cat-scan1.htm> © 2002 HowStuffWorks

# Magnetic Resonance Imaging

- Paul C. Lauterbur (University of Illinois) and Peter Mansfield won the 2003 Nobel Prize in Physiology or Medicine for their discoveries concerning MRI.
  - Showed that 2D images could be generated by implementing gradients the magnetic field.
- MR components
  - main magnet
  - Gradient coils
  - RF coil

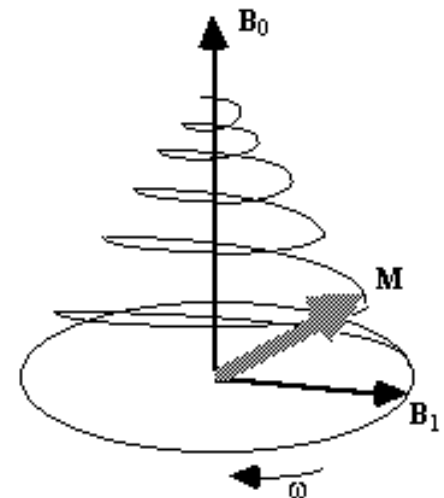
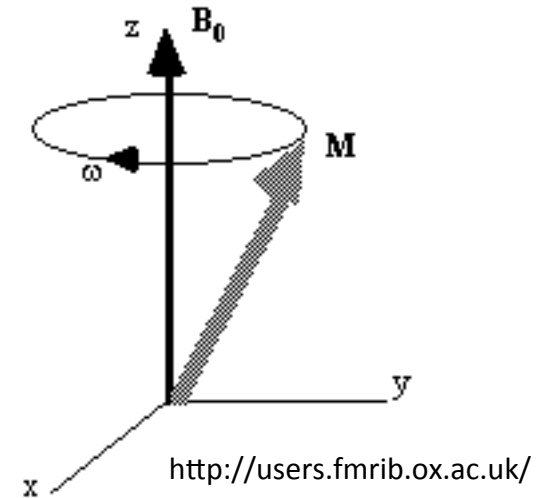
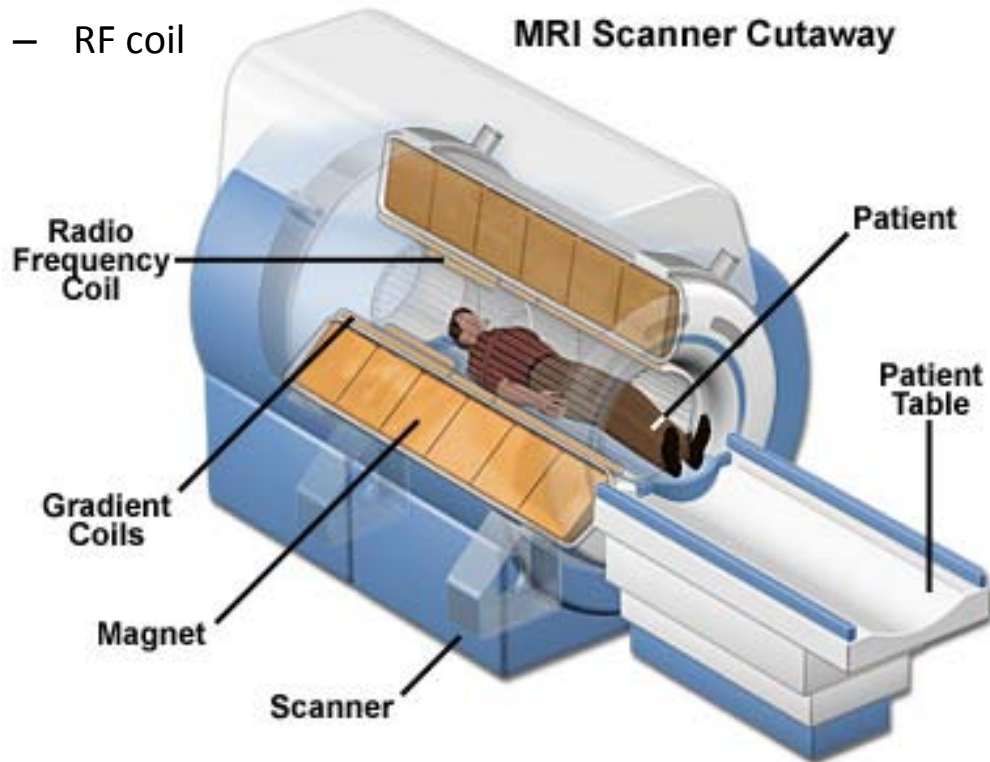

# Radioisotopes in medical imaging

- Utilize radiopharmaceuticals and the radiotracer principle to measure physiological processes
- Radioisotopes are produced via accelerator or reactor
- Radiochemistry is performed to attach the radioisotope to a molecule
- Radiopharmaceutical is injected into patient and imaged with a SPECT or PET scanner

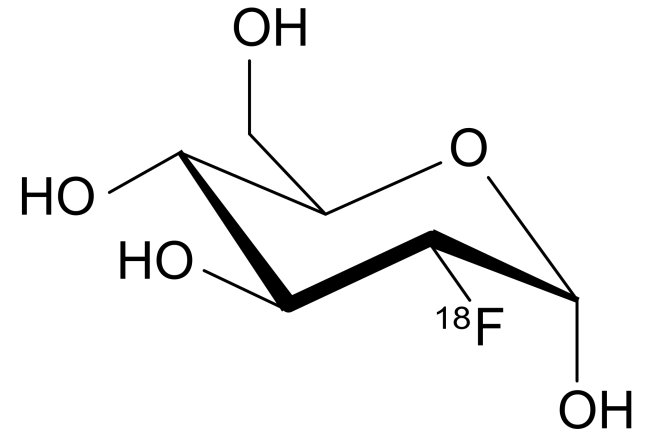

<http://www.sciradioactive.com/medicine/>

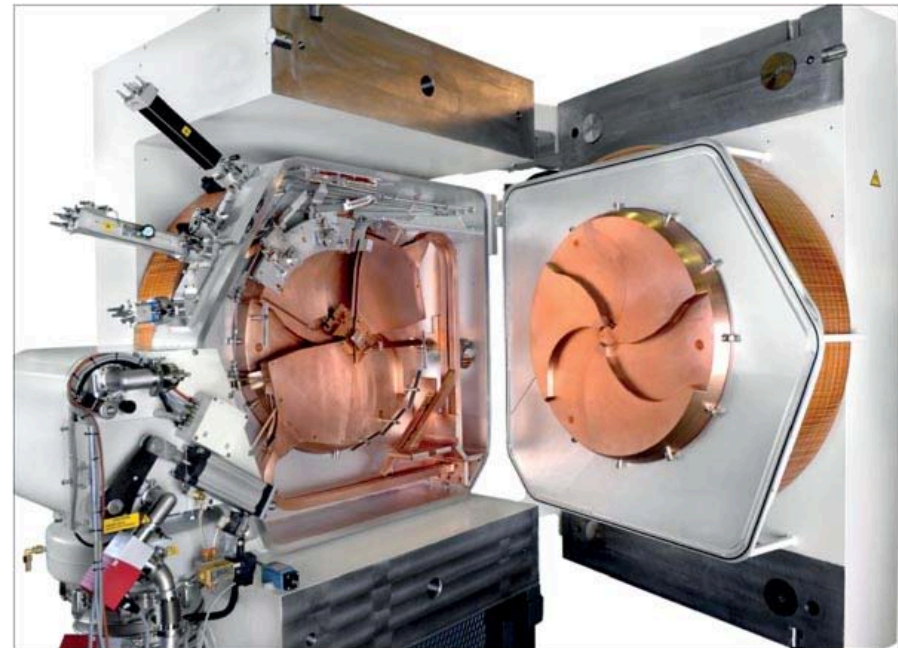

<http://geforcee.geblogs.com/radiopharmaceuticals-centre-opens-at-university-of-warsaw/>

# SPECT measures single photon emission

- Gamma camera
  - measures planar images (analogous to a planar X-ray)
- SPECT
  - generates a 3D image from multiple acquisition angles (analogous to CT)



Siemens

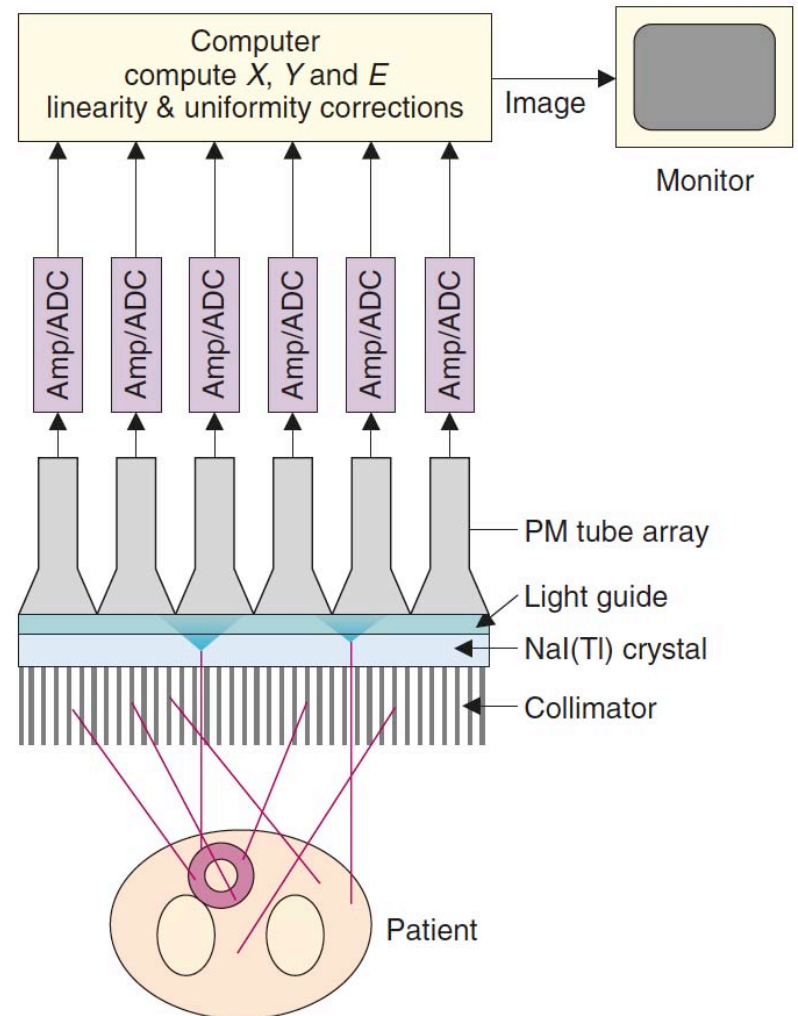

Cherry, S. R.; Sorenson, J. A.; Phelps, M. E. Physics in Nuclear Medicine; Elsevier, 2012.

# PET measures coincident photons

- A positron annihilates with an electron resulting in two gamma photons at  $\sim 511\text{keV}$
- Common PET isotopes
  - $^{15}\text{O}$ ,  $^{11}\text{C}$ ,  $^{18}\text{F}$ ,  $^{13}\text{N}$

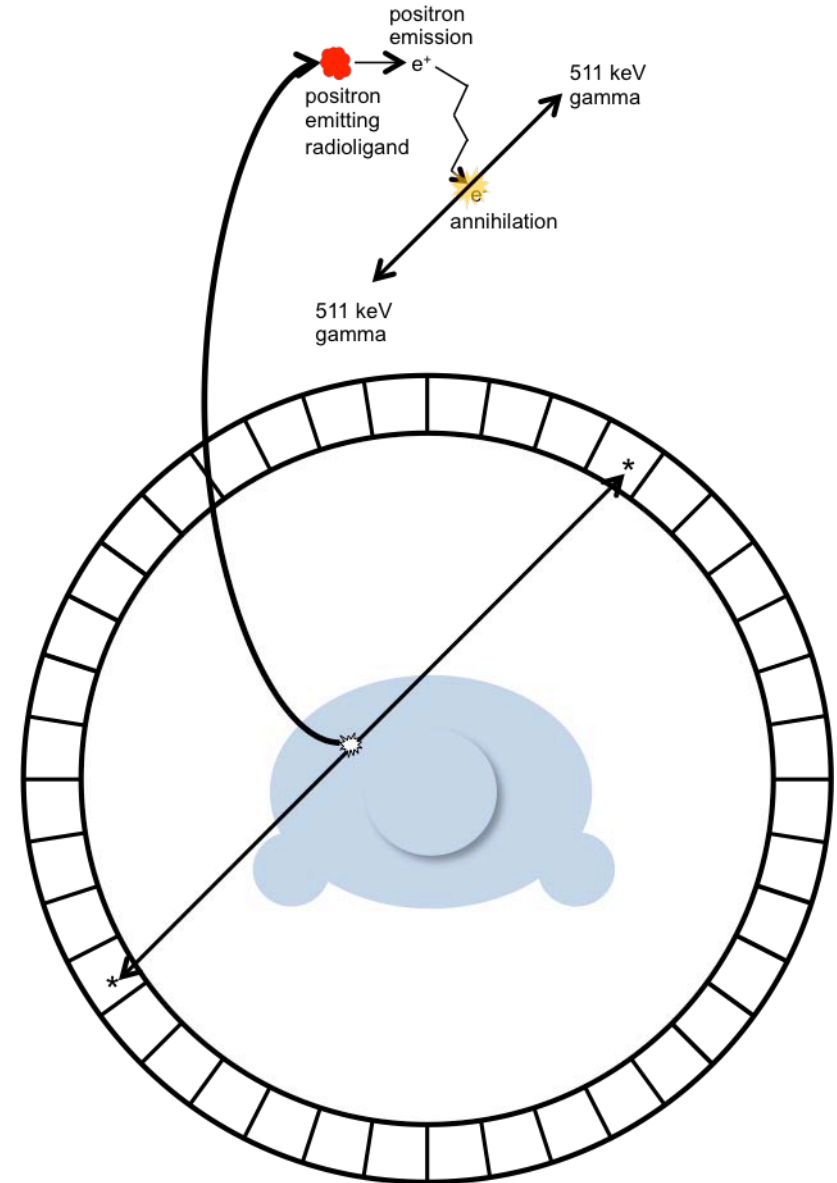

Siemens



# In radiation therapy:

- Perform quality assurance on sources of radiation
- External beam radiation therapy:
  - gamma
  - electron
  - proton
- Internal radiation therapy
  - brachytherapy
- Quality assurance:
  - verification of proper dosing
- Treatment planning



[http://www.varian.com/us/oncology/radiation\\_oncology/clinac/](http://www.varian.com/us/oncology/radiation_oncology/clinac/)

# External beam photon therapy uses high energy photons to deliver dose to tumors

- The goal is to deliver a high dose of radiation to tumor and spare the healthy tissue
- Radiation is delivered at different angles
- External beam is very common

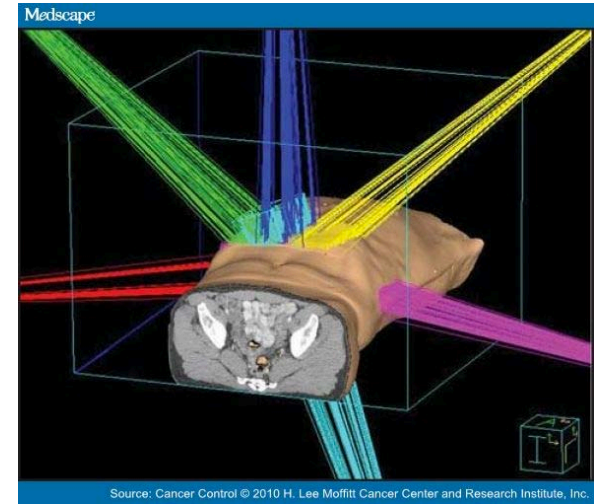

# Proton therapy is popular because it has good tissue sparing capabilities

- Uses a proton beam to deliver dose to tumor
- Energy deposition increases with penetration distance and most energy is deposited in the so called Bragg peak

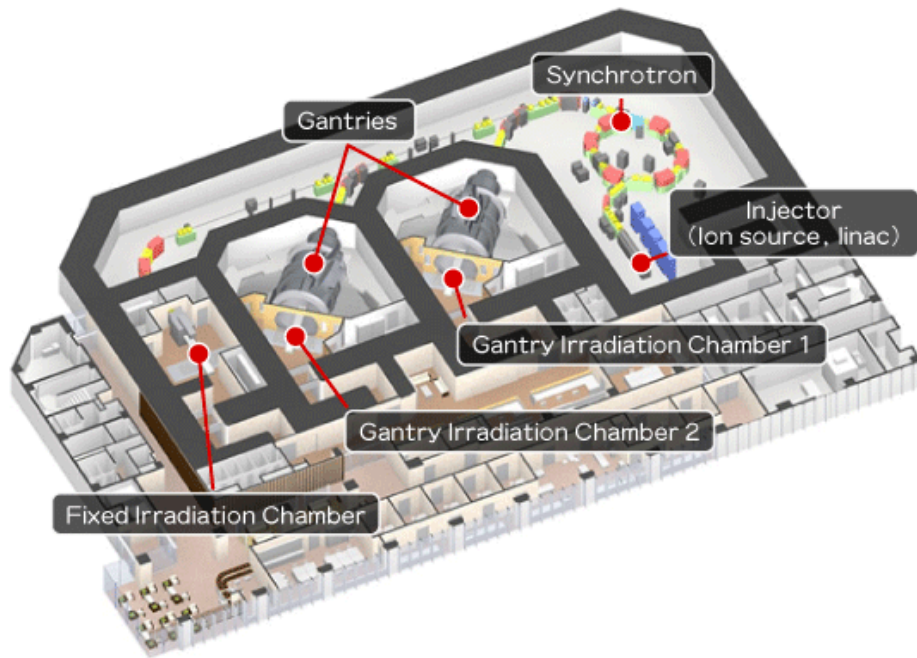

[http://www.nptc.city.nagoya.jp/e\\_proton/e\\_equipment.html](http://www.nptc.city.nagoya.jp/e_proton/e_equipment.html)

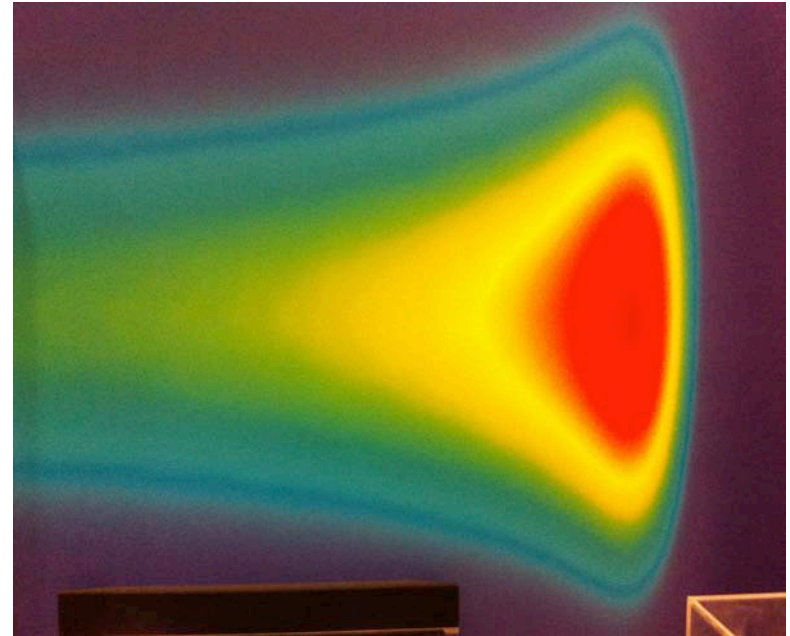

MGH Francis H. Burr Proton Therapy Center

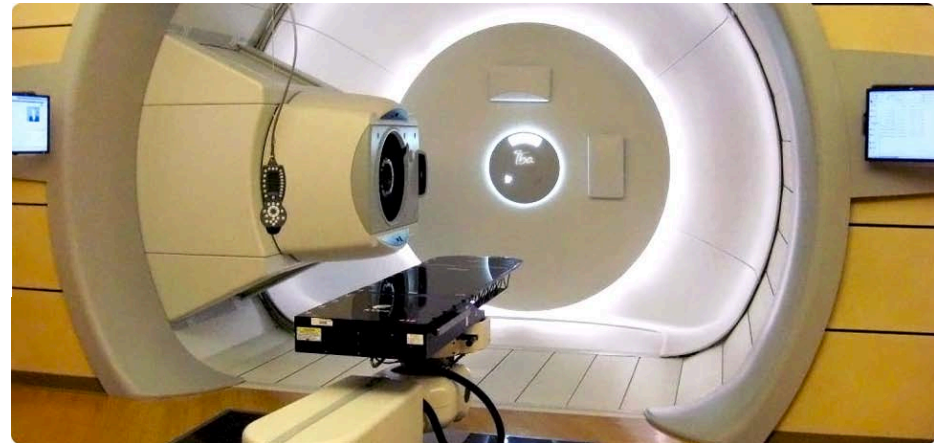

# Brachytherapy is a type of internal radiation therapy

- Small radiation sources are implanted either in or around the target tissue
- Temporary or permanent
- Can deliver higher doses of radiation in a smaller area over a shorter time than external techniques
- Delivered via tube or catheter

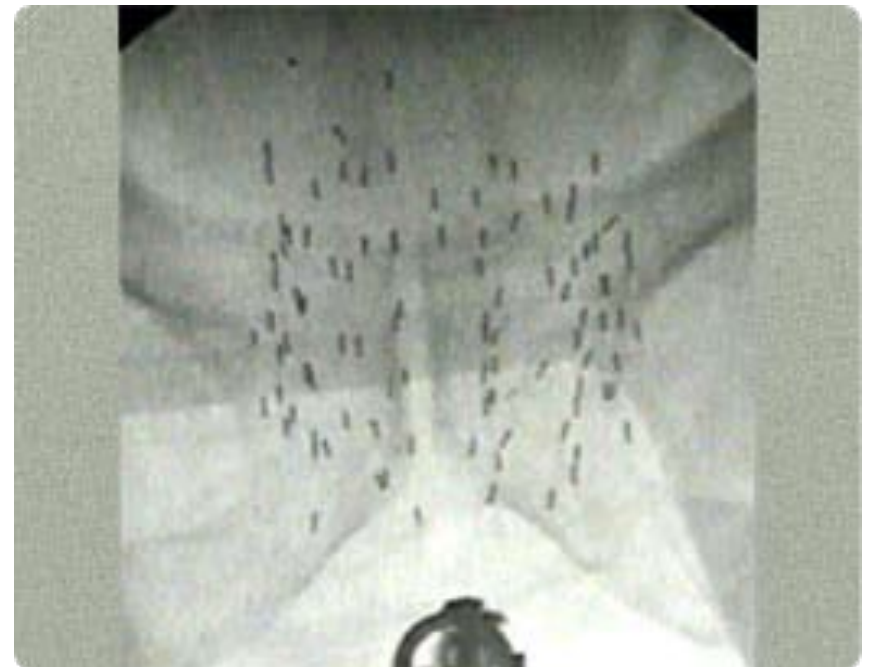
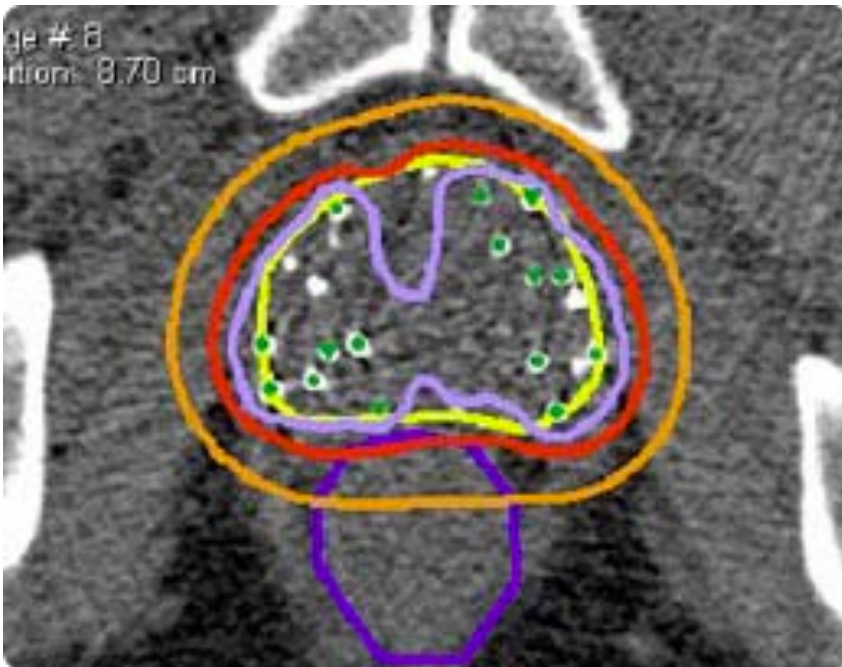

# Other roles of medical physicists

# Medical physicist are involved in policy for safety of workers and the public

- Task group reports (AAPM and ACR)
  - Measuring performance of imaging and therapy systems
  - Measuring dose from a variety of radiation sources and systems
  - Calculation of dose from imaging and therapy systems
  - Guides for medical physics programs
    - necessary coursework
    - Ethics curriculum
  - Even questions about dose from airport scanners
- Certifications
  - Medical physicists
  - Medical imaging scanners



# Medical physicist teach

- Often hold faculty positions at colleges and universities
- Train future medical physicist, physicians, and technologist
- Courses include:
  - Imaging specific courses: CT, MRI, ultrasound, PET/nuclear medicine, image reconstruction
  - Radiation therapy: treatment planning
  - Dosimetry
  - Health physics
  - Radiobiology
  - Metrology
  - Often train technicians on machine specific software
- Medical physics programs and training are overseen by the The Commission on Accreditation of Medical Physics Education Programs, Inc. (CAMPEP), which is jointly sponsored by the American College of Radiology (ACR), American Association of Physicists in Medicine (AAPM) and the American College of Medical Physics (ACMP).

# Health physics is a closely related field

- Medical physicist use radiation to treat and diagnose disease
- Health physicist ensure that the use of radiation in science, medicine, industry, or energy is safe for the worker, the public, and the environment
  - Monitor radiation levels
  - Transport of radiation
  - Radioactive waste
  - Advise on the use of radioactivity



# Medical Physics Research

# Medical physicist are heavily involved in research

Medical physicist are active in a wide range of areas from cancer and heart disease to mental illness.

- Cancer:
  - development of new radiation delivery methodologies (Tomotherapy)
  - study of how radiation effects biological processes (radiobiology)
  - dose calculation algorithms and software for interfacing
  - particle irradiation
- Cardiovascular disease:
  - CT
  - MRI
  - Nuclear medicine and PET
- New technologies
  - Dual energy CT
  - Quantitative and dynamic imaging

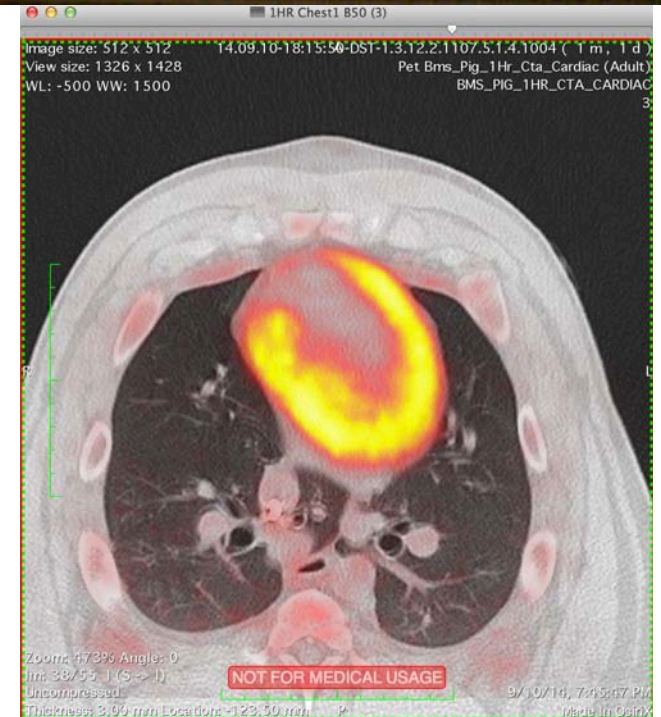

Yes, medical physicist are even involved in brain imaging

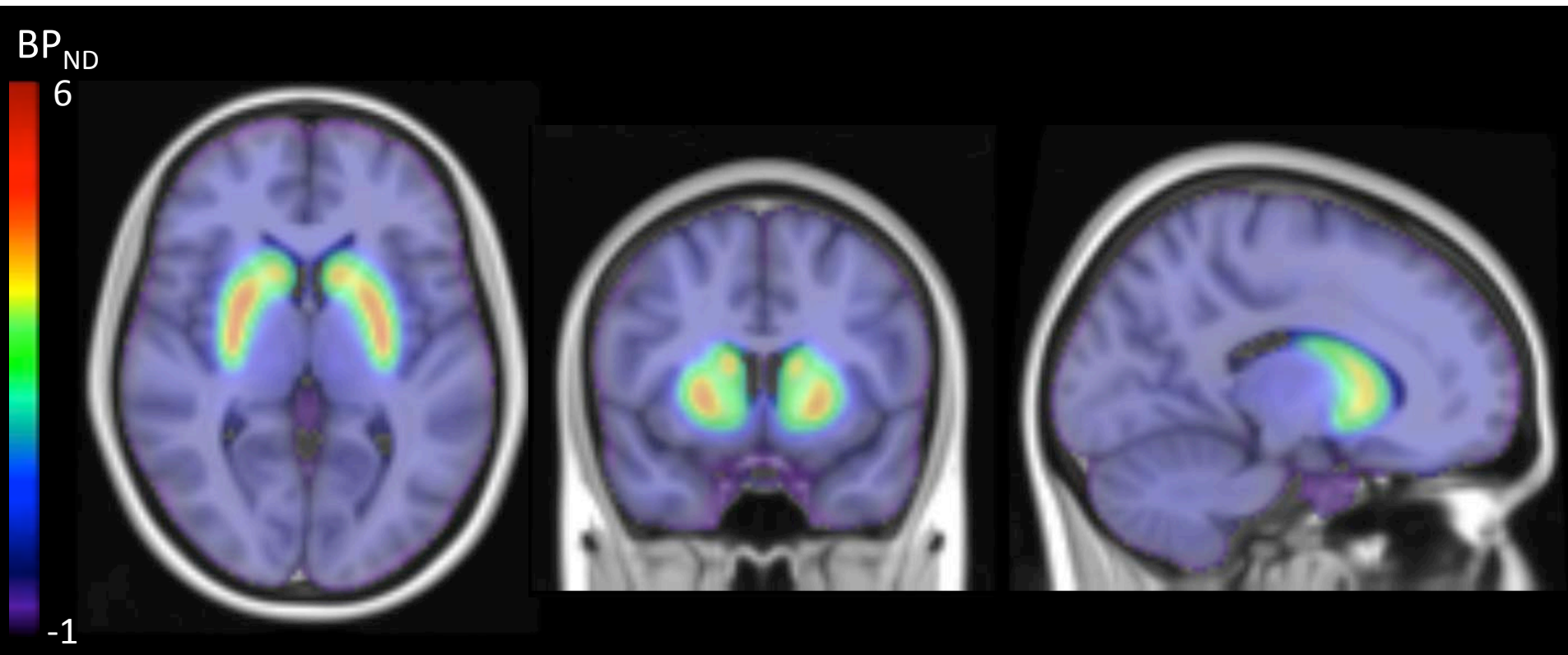

Image showing distribution of dopamine transporters in the striatum

# My experience in medical physics and research

- The immediate application of medical physics
- The application of physics to medicine
- I have been heavily involved in using PET to study brain function
  - Serotonin system
  - Drug-receptor interaction
  - Alzheimer's disease
  - TBI
- Other areas of PET

# PET to image the serotonin<sub>1A</sub> system

- Radiotracer
  - Radioactive chemical compound that has some affinity for a biological process
  - Receptor ligands
- Why the serotonin (more specifically the serotonin<sub>1A</sub>) system?

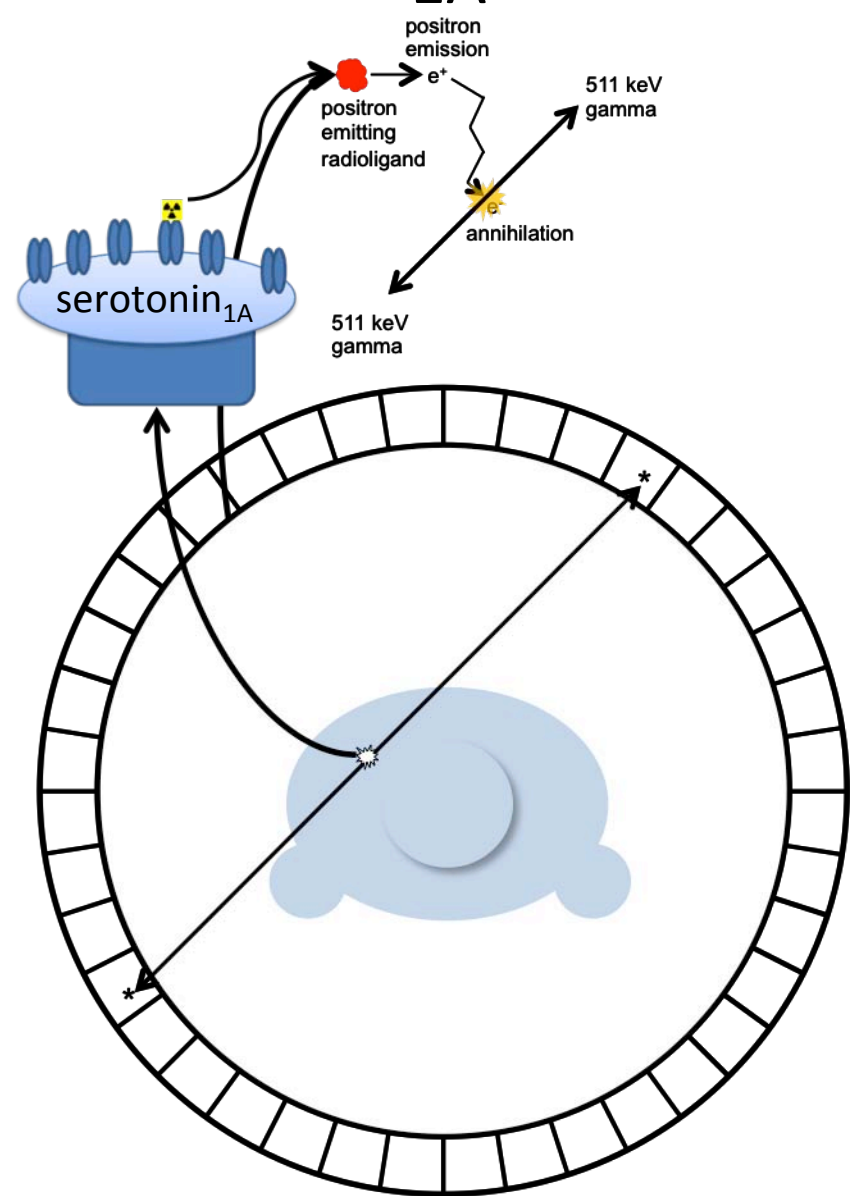

The serotonin<sub>1A</sub> (5-HT<sub>1A</sub>) receptor is a major regulator of serotonin function

- 5-HT<sub>1A</sub> autoreceptors in the raphe have an inhibitory effect
- Functions of the serotonin system linked to the 5-HT<sub>1A</sub> receptor include:
  - Anxiety and panic
  - Food uptake
  - Mood
  - Thermoregulation
- The 5-HT<sub>1A</sub> system is most closely associated with anxiety disorders and depression

# 5-HT<sub>1A</sub> receptor antagonists

- Most common PET 5-HT<sub>1A</sub> receptor antagonist are derived from WAY-100635

- [<sup>11</sup>C]WAY-100635
- [<sup>18</sup>F]MPPF
- [<sup>18</sup>F]FCWAY

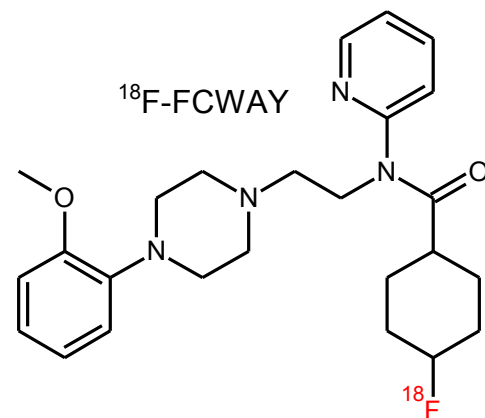
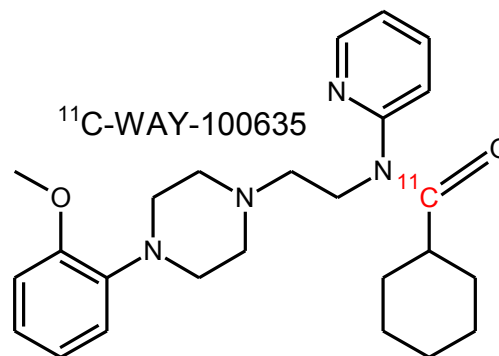

- [<sup>18</sup>F]Mefway was developed as an <sup>18</sup>F labeled alternative to [<sup>11</sup>C]WAY-100635

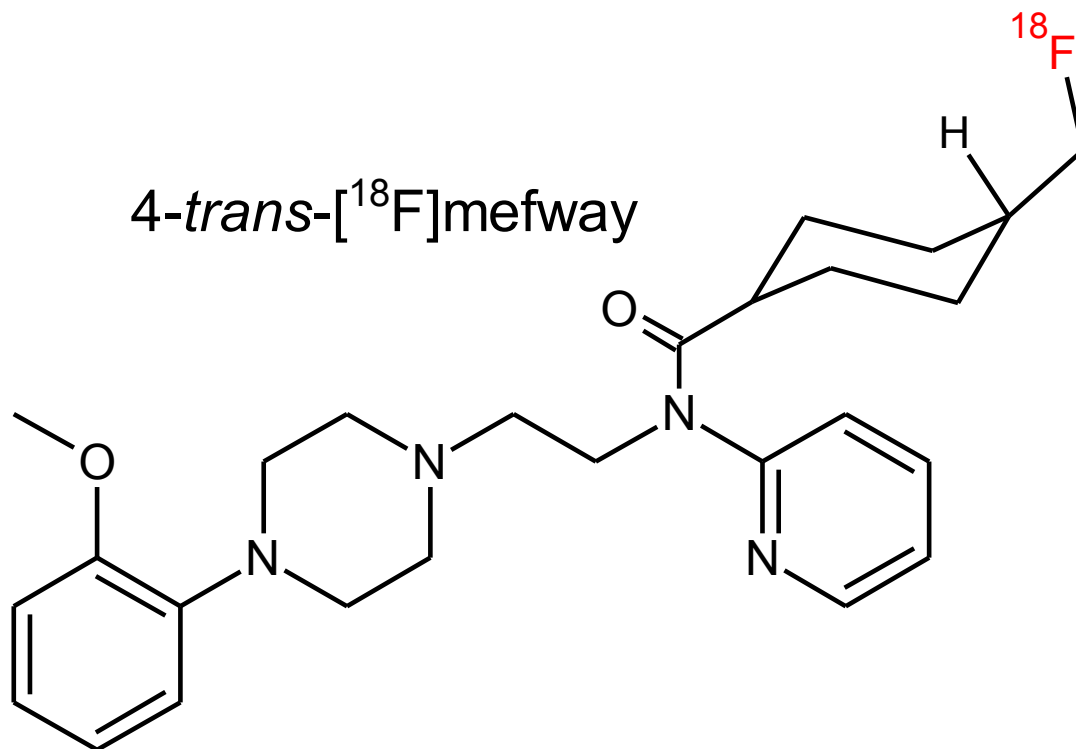

# [<sup>11</sup>C]WAY-100635 radiosynthesis

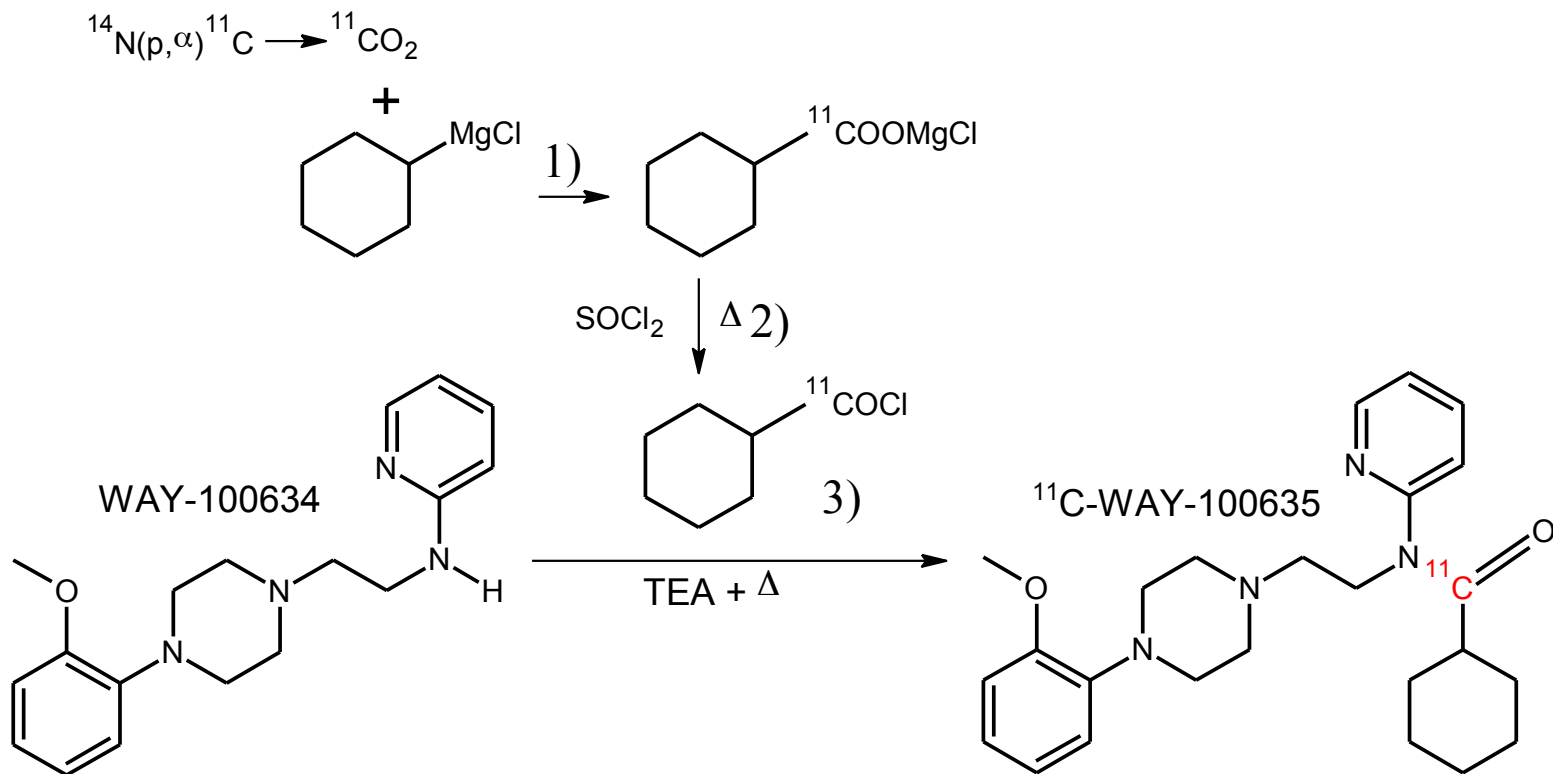

- 1) Accelerator produced  $^{11}\text{CO}_2$  reacts with cyclohexylmagnesium chloride to produce a carboxylation adduct
- 2) The carboxylation adduct reacts with thionyl chloride ( $\text{SOCl}_2$ ) to produce [carbonyl- $^{11}\text{C}$ ]cyclohexanecarbonylchloride
- 3)  $^{11}\text{C}$ -acylation of the secondary amine, WAY100634, produces [ $^{11}\text{C}$ -carbonyl]-WAY100635



# [<sup>11</sup>C]WAY-100635 production

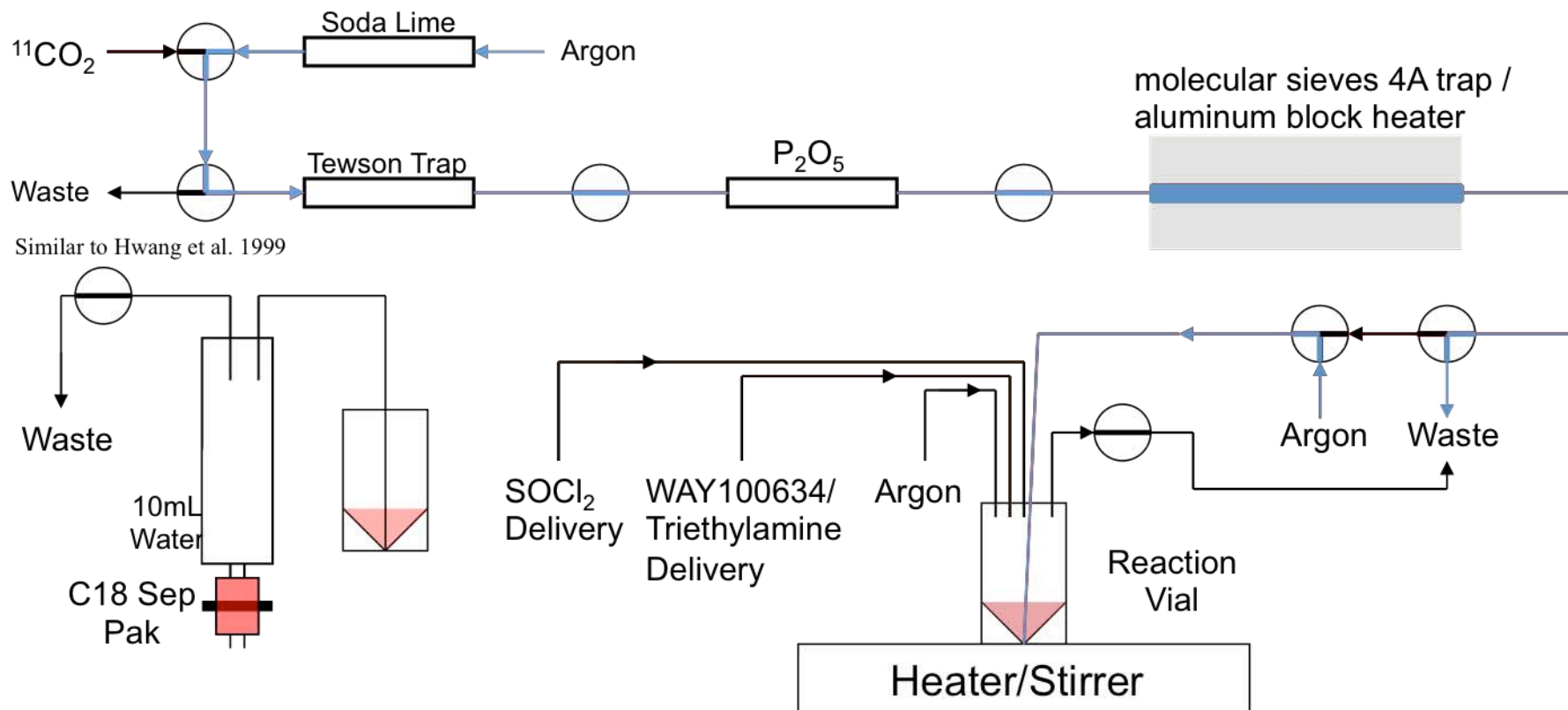

- <sup>11</sup>C<sub>2</sub> is trapped on molecular sieves
- Molecular sieves are heated to release <sup>11</sup>C<sub>2</sub> which is bubbled into Grignard solution carried by Ar
- SOCl<sub>2</sub> is added to mixture and heated under argon until mixture is dry
- WAY-100634 in THF is added to mixture and cooked for 5 minutes
- Mixture is added to 10 mL of water and passed through a C18 Sep Pak
- Sep Pak is rinsed with dilute solution of HCl, MeOH, and NaOH

# [<sup>11</sup>C]WAY-100635 purification

- Product is eluted from Sep Pak with 1 mL of EtOH and injected onto HPLC
- [<sup>11</sup>C]WAY-100635 is collected at ~550 seconds
- Typical yields of ~50 mCi (1.85 GBq) with specific activity ~1000-2500 mCi/μmol (37-93 MBq/nmol)

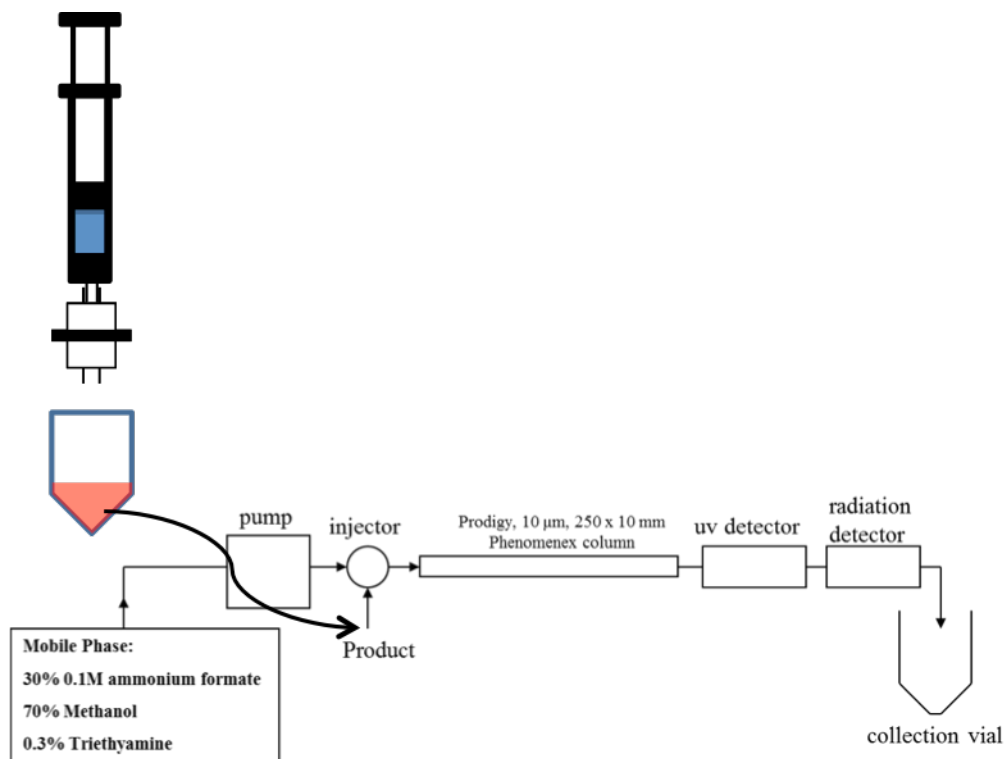

Analytic

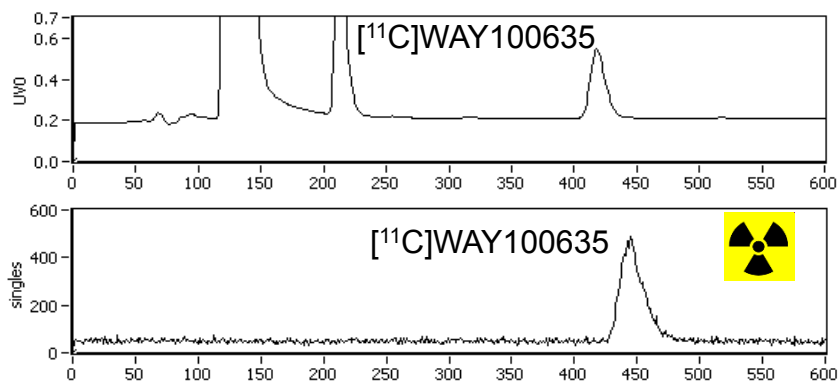

Analytic was performed using a Phenomenex Prodigy 5u 0DS3 100A column with mobile phase consisting of 55% 0.1M ammonium formate solution and 45% acetonitrile at 2.5mL/min

Semi-preparative

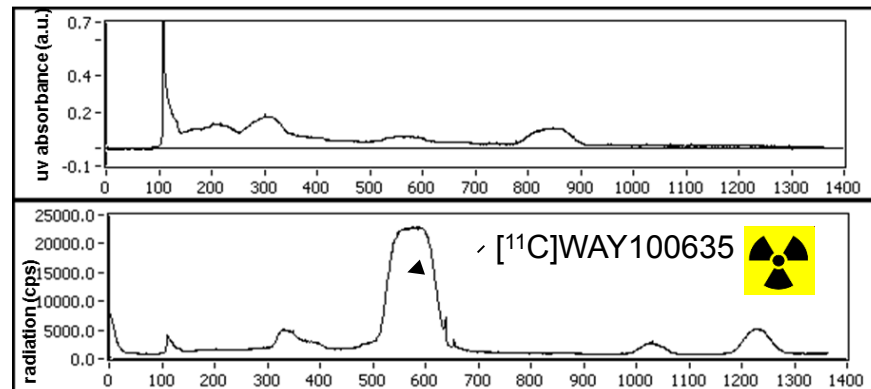

# [<sup>18</sup>F]Mefway radiosynthesis is much easier

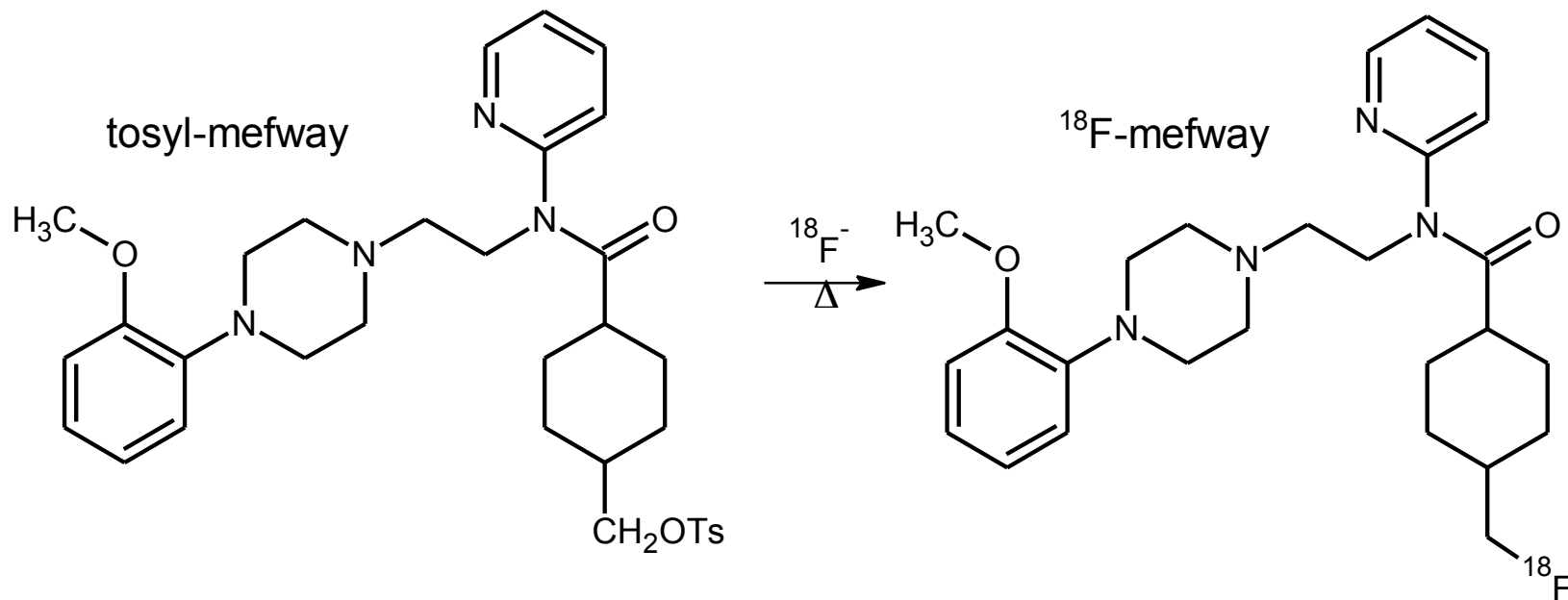

Synthesized by a nucleophilic substitution of the tosylate precursor

- [<sup>18</sup>F]F<sup>-</sup> was produced by bombardment of protons on H<sub>2</sub><sup>18</sup>O
- Water was removed from the [<sup>18</sup>F]F<sup>-</sup> by azeotropic distillation with acetonitrile
- ~1mg of *trans*-tosyl mefway in anhydrous acetonitrile was added to the <sup>18</sup>F and heated to 96°C

# Now that we have a radiotracer, what do we do with it?

- The radiotracers get injected intravenously into human or animal research subjects
- The cardiovascular system delivers the radiotracer throughout the body

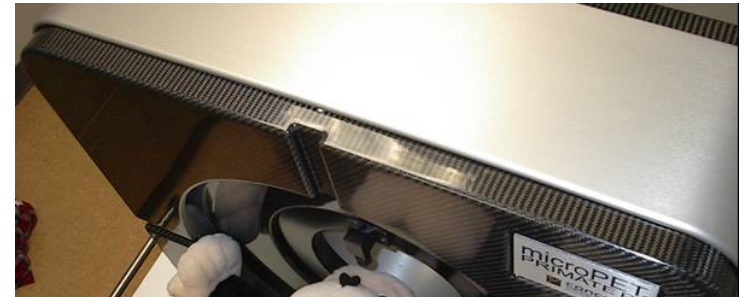
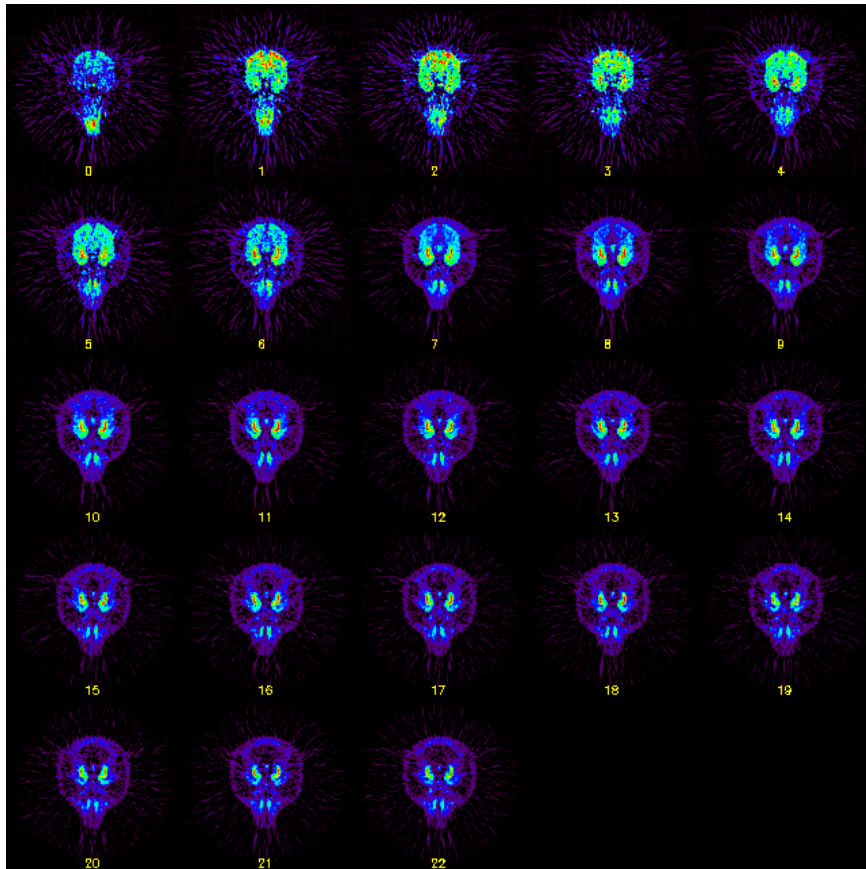

# PET imaging allows us to noninvasively see inside the brain

- Using PET we can view the distribution of the radiotracer over time
- PET imaging with [ $^{18}\text{F}$ ]mefway shows distribution of serotonin-1A receptors

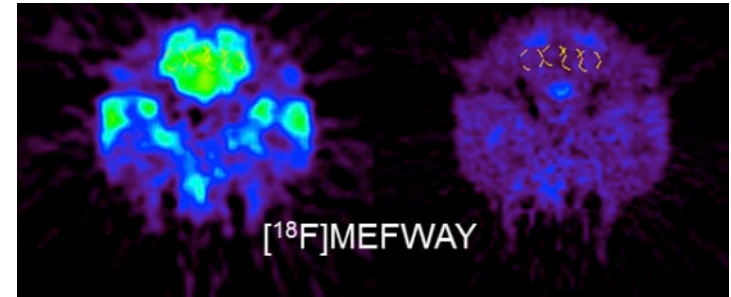

0-5 minutes

30-90 minutes

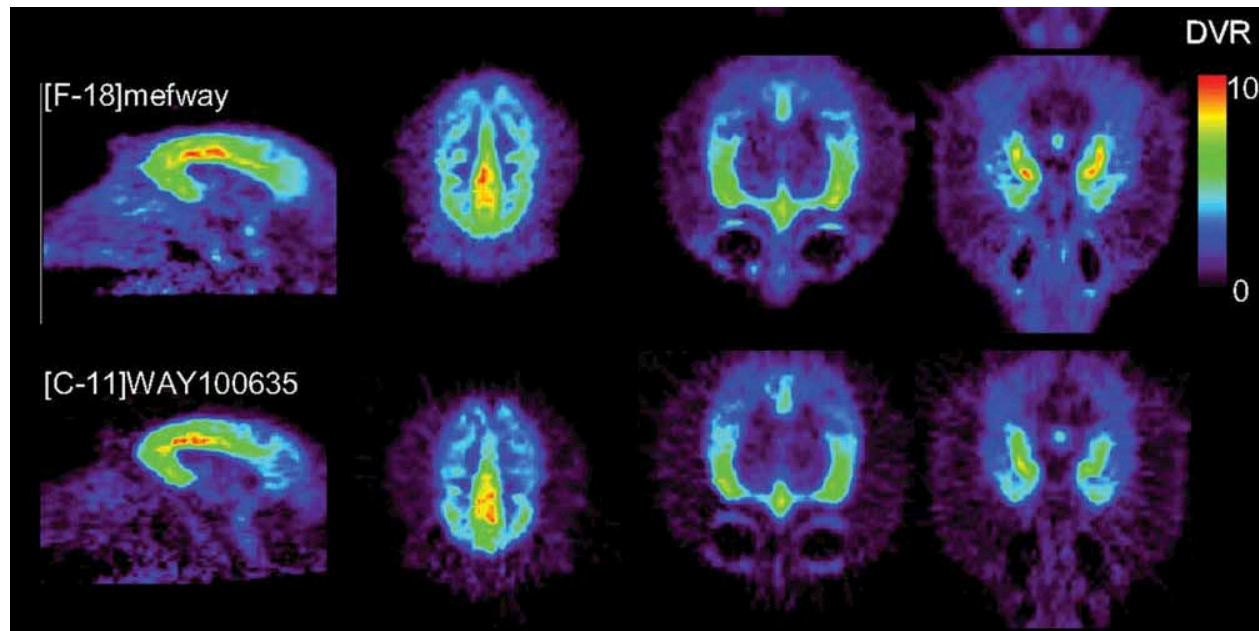

# Summary and Conclusions

- Medical physicist are involved in the application of physics and the development and use of radiation for diagnosis and treatment of disease
  - Medical imaging (CT, MRI, Nuclear Medicine and PET)
  - Radiation therapy
- Clinical medical physics is generally in three main areas:
  - Therapeutic Medical Physics
  - Imaging Medical Physics
  - Nuclear Medical Physics
- Medical physicist are involved in a wide range of research areas:
  - Cancer
  - Cardiovascular
  - Neuroimaging

Many thanks!



THE UNIVERSITY  
*of*  
**WISCONSIN**  
MADISON



MASSACHUSETTS  
GENERAL HOSPITAL



HARVARD  
MEDICAL SCHOOL