

8

A **single electron transistor** (SET) consists of a square quantum dot placed in proximity to three conductors: two leads and a gate. The dot is separated from the two leads by small gaps (called “tunnel barriers”), across which single electrons may hop. The leads are grounded, i.e., $V_L=0$. The gate is separated from the dot by a gap, and its only effect is to capacitively alter the potential energy offset of the dot.

The quantum dot may be approximated as a three-dimensional square well with potential given by

$$V(x, y, z) = \begin{cases} -eV_g & 0 \leq x \leq L \text{ and } 0 \leq y \leq L \text{ and } 0 \leq z \leq d \\ V_{edge} & \text{otherwise} \end{cases}$$

The bottom left corner of the dot is taken to be the origin, L is the side length of the dot, d is its height, and $L \gg d$. The quantity V_g represents the effect of the gate, so $V_{edge} + eV_g$ may be considered to be the depth of the well.

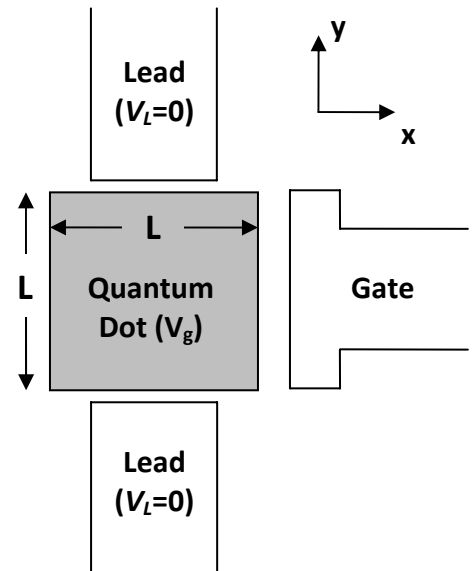

- (a) Assume the dot is occupied by one electron. Determine the wave functions for the ground state and the first excited state of the quantum dot. For this part you may assume the quantity $V_{edge} + eV_g$ is very large, so the system can be approximated as an infinite square well.
- (b) Determine the energies associated with the wave functions in part (a). Indicate the degree of degeneracy of each.
- (c) Assume now that the dot is empty. Determine the minimum gate voltage, V_g , that must be applied for an electron to hop from one of the leads onto the dot.

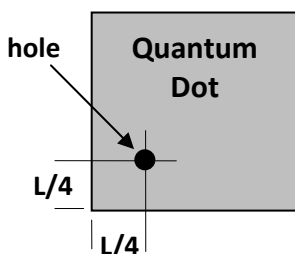

A scanning electron microscope (SEM) is used to drill a hole in the dot, at the location shown in the figure (left).

- (d) Will the energy levels of the dot increase or decrease? Explain your answer.
- (e) We model the effect of the hole as a perturbing potential, $V'(x, y, z) = V_0 \delta(x - L/4) \delta(y - L/4)$. Determine the corrections to the ground state and first excited state energies, to first order in V' . (Note: the problem is degenerate).