

ISE REU Project Report

**Prototyping Electro-Hydrostatic Actuators for
Resilient Flight Controls**

Samuel E. Zelman

Faculty Advisor: Dr. Pingfeng Wang

*Department of Industrial and Enterprise Systems Engineering, University of Illinois at
Urbana-Champaign, Urbana, IL 61801*

August 3, 2018

Table of Contents

ABSTRACT	3
I: INTRODUCTION	4
II. DESIGN OF ELECTRO HYDROSTATIC ACTUATOR (EHA)	5
II.1. The EHA System Circuitry Design	6
II.2. The EHA System Code Development	7
III. THE EHA SYSTEM REALIZATION	10
IV. CONCLUSION	14
ACKNOWLEDGEMENT	15
REFERENCES	16

ABSTRACT

The growing global trend toward increased system complexity and prolonged service life presents unprecedented challenges for system designers to innovate the necessary tools for an emerging need of high-reliability, low-cost systems. To address the challenges, a new resilience methodology is presented and applied to the design of an electro-hydrostatic actuator (EHA) based flight control system. Failures of the EHAs in flight control can be catastrophic, resulting in great loss of life. Therefore, it must be designed to achieve a sufficiently high level of reliability. As a closed-loop control system, the presented EHA mainly consists of an electronic control unit, a variable-speed electric motor, a fixed-displacement hydraulic pump, and a hydraulic actuation system. The resilience of the EHA control system design was regulated using various control mechanisms, and the testing results were acquired during operation of the system under various failure conditions, providing the validation of the design for failure resilience methodology. The presented study results demonstrate that failure resilience of a complex engineering system can be enhanced by using the design-for-resilience approach, which integrates system functionality design with the failure control strategies.

I. INTRODUCTION

Originally used in flight control technology, EHAs have expanded into other industries. Recent advancements have led to a simplification of the system from centralized hydraulic to a localized actuator. The EHA used in flight controls is an actuator system to replace traditional hydraulic systems that require complex usage of mechanical power. The EHA utilizes a Power-by-Wire (PBW) actuation system that includes a self-contained electrical system and fully electric actuation. PBW is believed to be the future of resilient flight controls due to its lower costs, weight, and improved safety control [1]. The EHA's main components are a control unit, servo motor, hydraulic pump, and an actuation system with a hydraulic cylinder. The single rod cylinder has been analyzed in a closed loop EHA [2]. A Linear Variable Differential Transformer (LVDT) is attached to the hydraulic cylinder, connecting the control algorithm in a closed loop. The algorithm, implemented with Arduino, is used to vary the motor speed and direction. A hydraulic pump that is connected to the motor is used to transfer rotational energy into linear energy. The control algorithm uses the Proportional Integral Derivative (PID) controller theory as a feedback mechanism. The PID algorithm has proven to be an effective control mechanism in a similar system design [3,4]. Below in Fig. 1 is an outline of the EHA setup structure.

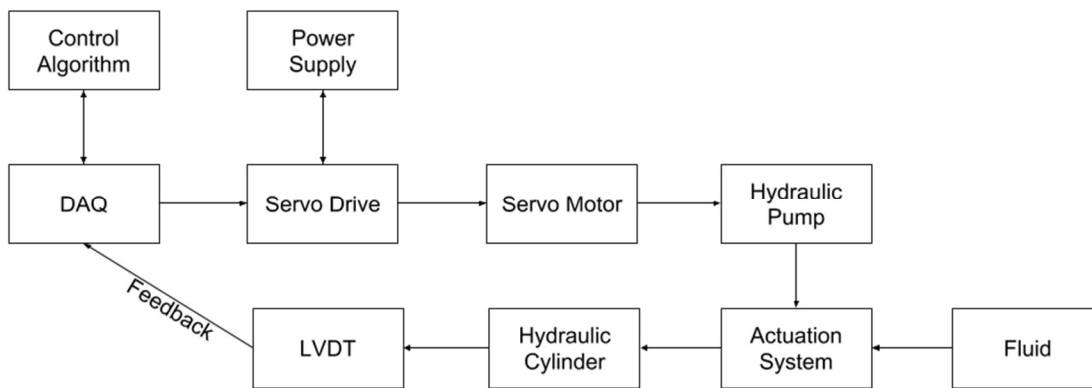
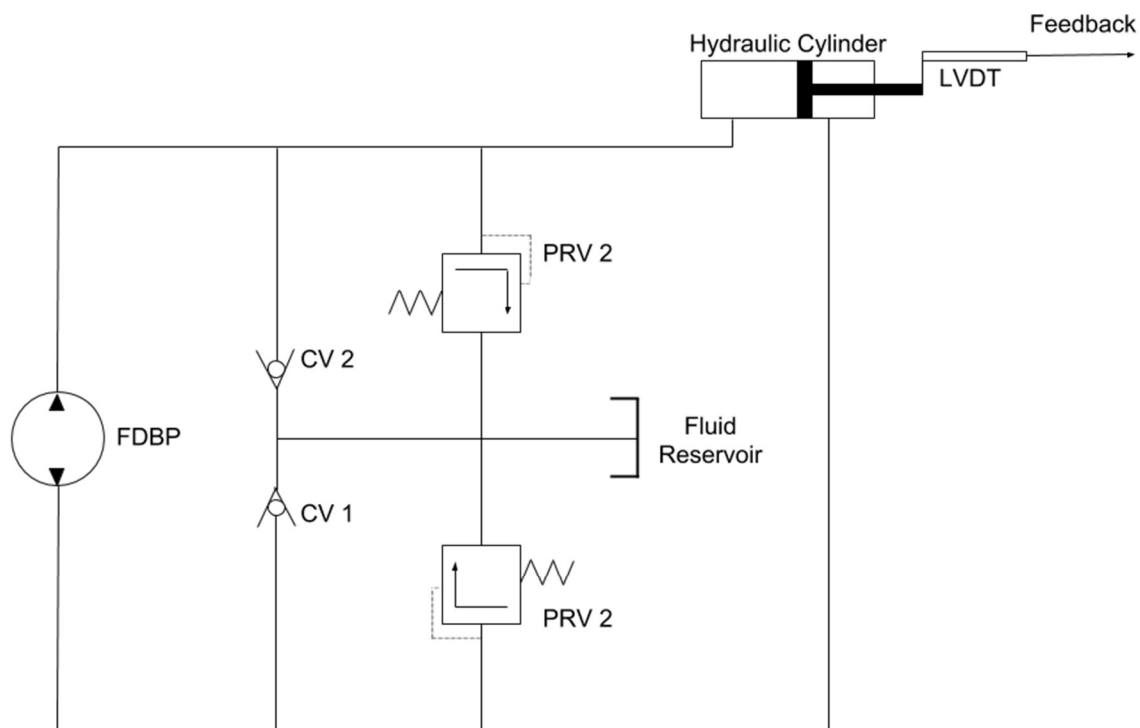

Figure 1. The EHA System Functional Block Diagram

II. DESIGN OF ELECTRO HYDROSTATIC ACTUATOR (EHA)

The EHA system was modelled using a localized hydraulic system controlled by a bi-rotational servo-motor. The 400 watts and 3000 RPM motor powers the 3600 RPM pump. The pump then converts rotational energy into linear energy, pushing fluid in the desired direction. Mineral hydraulic oil is poured into the system and through the non-return check valves on either side. Pressure relief valves regulate pressure inside the system. Fluid flow control is implemented using 15-inch hoses with $\frac{3}{8}$ inch diameters. A 12 mm rod is used as an actuator while the LVDT converts a measured displacement into voltage. The LVDT connects back to the A0 port in the Arduino, and is read by the `analogRead()` function in the Implemented Arduino code. Fig. 2 shows the overall layout of the hydraulic system.



FDBP - Fixed Displacement Bi-Directional Pump; CV - Check Valve; PRV - Pressure Relief Valve

Figure 2. The Block Diagram of the Actuation System

An Arduino Uno microcontroller is used to produce a Pulse Width Modulation (PWM) signal. Advantages of the Arduino are its open source network and simple programming platform. Using the zero voltage reading position of the LVDT as a reference point, position of the rod of the hydraulic cylinder can be measured in voltage and thus the motor drives the cylinder accordingly. As the actuator extends past the command point, the motor reverses direction and retracts towards the command position. The control algorithm utilizes the PID control algorithm, shown below:

$$f(t) = K_p e(t) + K_i \int_0^t e(t) dt + K_d \frac{de(t)}{dt}$$

In PID control, the error term can be manipulated in three ways and used as a means to control the system. PID was chosen due to its simple structure and ease of setup. In this EHA design, only the proportional controller is used and implemented into the Arduino code. This is due to a risk of overshoot from the integral term and variable impact from the derivative term. The controller uses a circuit to connect the electrical components to the actuator system, as introduced in the next section.

II.1. The EHA System Circuitry Design

The control circuit of the EHA system utilizes a large breadboard to organize the wiring of the system. It provides connections between the power supply, Arduino, and digital AC servo driver. The servo driver has six ports connecting the Arduino, four ports to the motor, and two to the power supply. The power supply also connects to the Arduino through the GND and A0 ports. The connection layout is shown below:

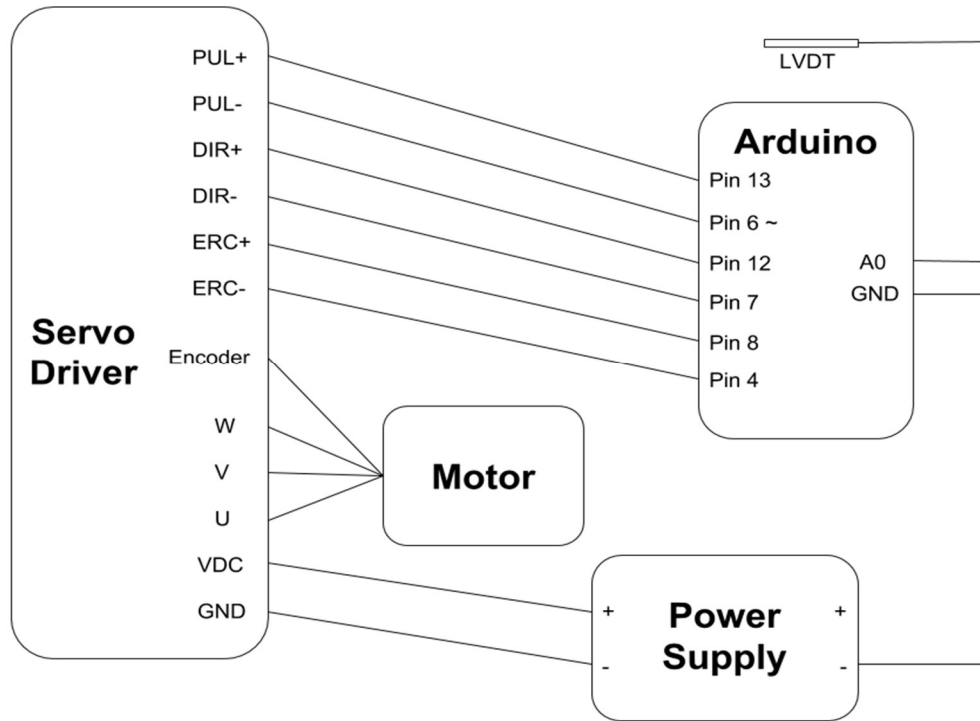

Figure 3. The Connection Diagram of the EHA System Circuit Design

As shown in Fig. 3, the position and speed of the motor is acquired by the encoder, “W”, “V”, and “U” ports on the servo driver. Moreover, the servo driver communicates with the Arduino microcontroller through the top 6 ports. “PUL+”, “DIR+”, and “ERC+” work as ground reference while “PUL-” receives the PWM command used for speed control. “DIR-” is used for setting the direction of the motor and “ERC-” controls the “ON/OFF” of the motor.

II.2. The EHA System Code Development

The EHA code is written in the Arduino integrated development environment (IDE). The six ports on the Arduino that are connected to the servo driver are first initialized as shown in line 1 through line 6 as shown on the next page. The voltage outputted from the LVDT is read and used to control the motor. A reference command of 750 is used to represent the desired position, in a total range of 0~1023. Thus the error between the desired position and current actuator position

can be calculate as integer, which is further used to control the motor speed as shown in line 32 and 42. The float *Delay* determines the speed in which the program runs and thus control the magnitude of PWM signal that actuates the stepper motor, corresponding code can be found as line 35 or 37. In the *void setup()* portion of the code, the pins are all set to produce an output. *DigitalWrite()* is used to configure either a HIGH (5V) or LOW (0V) output from the pins. Two *while* loops control the motor speed and direction as the motor actuates the hydraulic cylinder. DIR_Neg controls the direction of the motor and changes depending on the loop accessed.

```
1.  int PUL_Pos = 13;
2.  int PUL_Neg = 6;
3.  int DIR_Pos = 12;
4.  int DIR_Neg = 7;
5.  int ERC_Pos = 8;
6.  int ERC_Neg = 4;
7.
8.  float Voltage = 0; //Voltage readings from LVDT (0-5V represented as 0-1023)
9.  float Command = 750; //Position command in Volts (0 ~ 1023)
10. float Delay = 1;
11. float Error = 0;
12.
13. void setup() {
14.   pinMode(PUL_Pos, OUTPUT);
15.   pinMode(PUL_Neg, OUTPUT);
16.   pinMode(DIR_Pos, OUTPUT);
17.   pinMode(DIR_Neg, OUTPUT);
18.   pinMode(ERC_Pos, OUTPUT);
19.   pinMode(ERC_Neg, OUTPUT);
20.
```



```
21.  digitalWrite(PUL_Pos, HIGH);
22.  digitalWrite(DIR_Pos, HIGH);
23.  digitalWrite(ERC_Pos, HIGH);
24.  digitalWrite(ERC_Neg, HIGH); //HIGH: ON LOW: OFF
25.  }
26.
27.  void loop() {
28.    Voltage = analogRead(A0);
29.    while(Voltage > Command){
30.      //need to push the cylinder inward, fluid flows into right chamber, pump rotates in
      CW, motor in CCW, LOW
31.      Error = Voltage - Command;
32.      Delay = 50/Error; //Should be 10~4000
33.      digitalWrite(DIR_Neg, LOW);
34.      digitalWrite(PUL_Neg, HIGH);
35.      delayMicroseconds(Delay);
36.      digitalWrite(PUL_Neg, LOW);
37.      delayMicroseconds(Delay);
38.    }
39.    while(Voltage < Command){
40.      //need to push the cylinder outward, fluid flows into left chamber, pump rotates in
      CCW, motor in CW, HIGH
41.      Error = Command - Voltage;
42.      Delay = 50/Error; //Should be 10~4000
43.      digitalWrite(DIR_Neg, HIGH);
44.      digitalWrite(PUL_Neg, HIGH);
45.      delayMicroseconds(Delay);
46.      digitalWrite(PUL_Neg, LOW);
47.      delayMicroseconds(Delay);
48.    }
```

III. THE EHA SYSTEM REALIZATION

The design of the EHA system as detailed in Section II has been developed in the Reliability Analysis and Safety Assurance (RASA) laboratory. The system realization has been shown in the following figures. Fig. 4 shows the components used for the EHA system development, and figure 5 shows the realization of the designed EHA system.

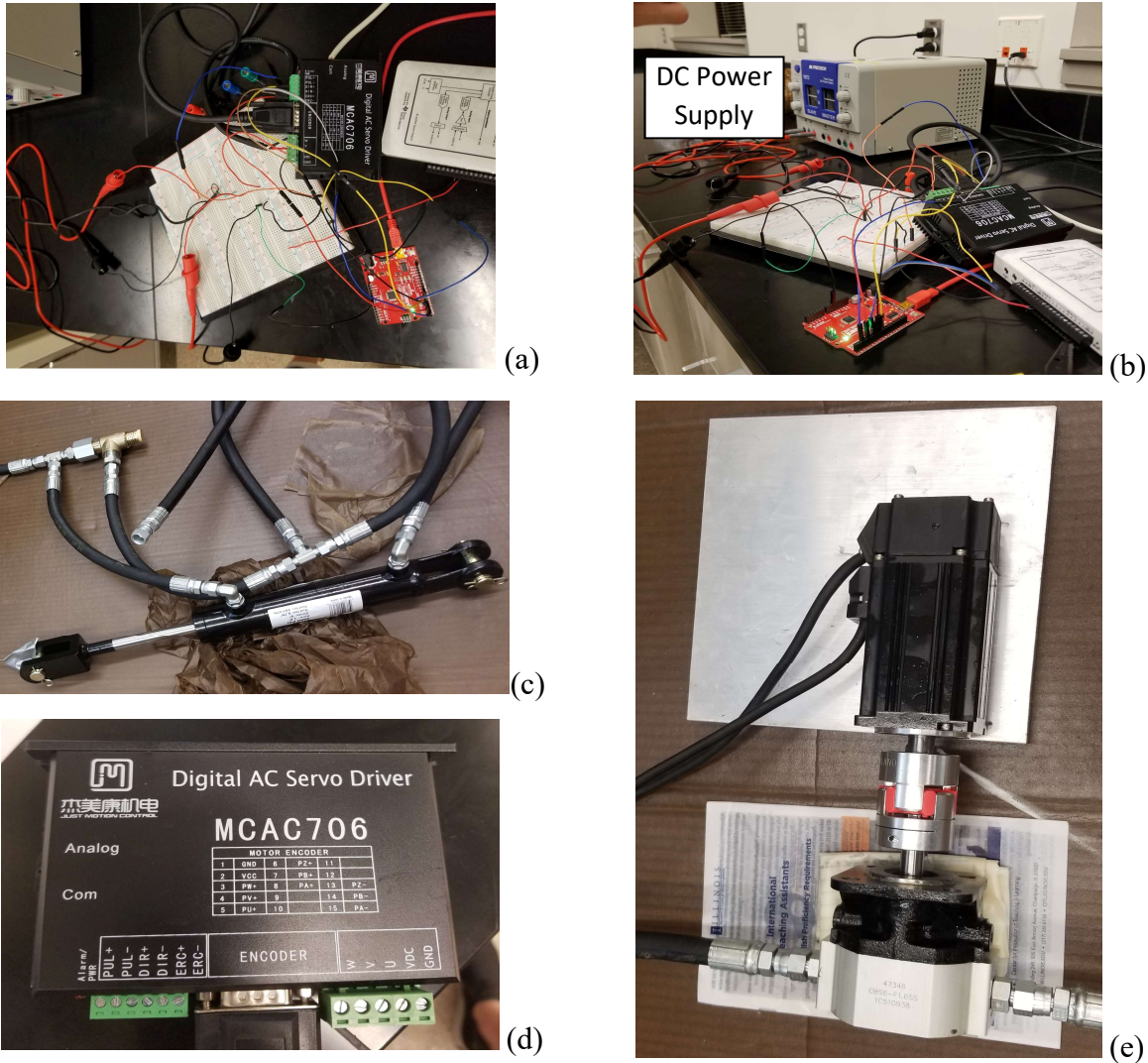

Figure 4. The Components for the realization of the EHA System Design (a) the Circuitry Design; (b) the Power Supply with the Circuitry; (c) the Hydraulic Cylinder and LVDT; (d) the Servo Driver; and (e) the Motor and Pump.

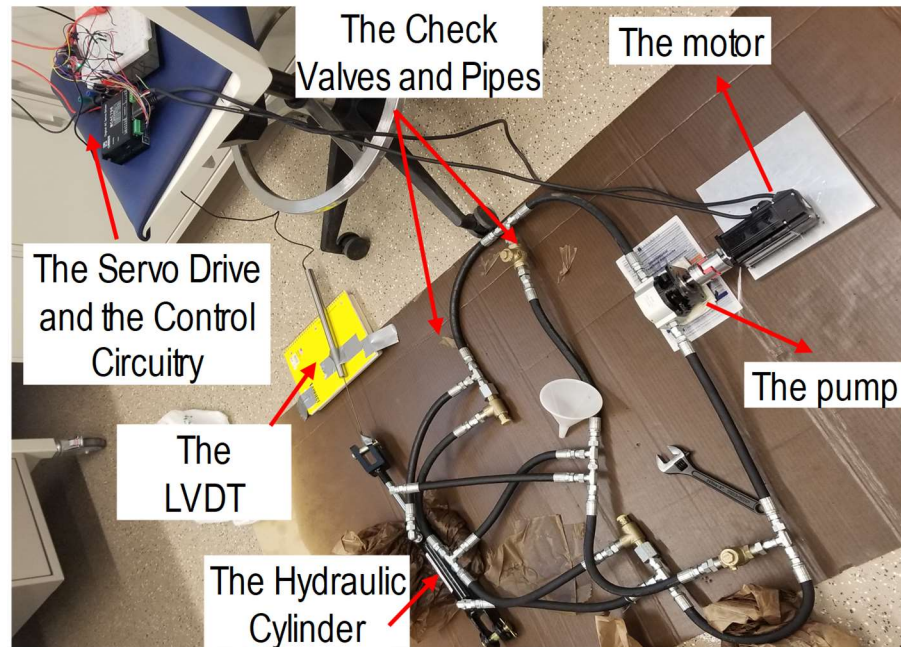

Figure 5. The overview for the prototype realization of the EHA System Design in the laboratory.

As shown in Fig. 4 and Fig. 5, a combination of electric and mechanical parts was utilized in this project. Table 1 is the list of components that make up the EHA system as well as their corresponding technical specifications.

Table 1: The Components Used for the EHA System Design

Component Name	Component Specs	Quantity
DC Power Supply	2 channels of 0~32 V range	1
Hydraulic Cylinder	2 in stroke with a rod of 0.02 m diameter	1
Hydraulic Pump	1.2 GPM with 3050 Psi maximum working pressure	1
Servo Motor	Nominal power 400 W with 3000RPM speed	1
Servo Motor Driver	MCAC706 with inherent encoder	1
Linear Variable Displacement Transformer (LVDT)	2 in stroke with 0.2% accuracy	1
Pressure Relief Valve	NPT type 1/2 in diameter	2
Check valve	NPT type 1/2 in diameter	2
Industrial Application Hydraulic Hoses	JIC type 9/16-18	11
MJIC to MJIC Adapters	Convert JIC 9/16-18 to JIC 9/16-18	4
MJIC to MNPT Adapters	Convert JIC 9/16-18 to NPT 1/2-18	6
MJIC to MJIC to FJIC Tee Valves	Convert JIC 9/16-18 to two JIC 9/16-18	7
Arduino Board	Arduino UNO with PWM signal output pin	1
myDAQ	Data acquisition with 10KHz frequency	1

Once the system is set up, the displacement of the hydraulic cylinder is acquired by the external data acquisition system. The EHA system response curve is shown in Fig. 6 with a command position at 2.4 inches. It shows that the hydraulic cylinder follows a “staging” movement, which implies that the hydraulic fluid does not flow smoothly. The settling time of the current system design is relatively long: oscillation continuous after 60 secs. However, the overall trend of the displacement curve meets the desired performance, since it converges to the 2.4-inch command point. Also, due to the noise of the data acquisition system, there are many outliers during the oscillation stage. However, the reading showing the actual movement of the cylinder is still significant and clear. In the future, improvements for the current stage setup will include several reconfigurations, such as more compact system layout and more accurate control algorithm.

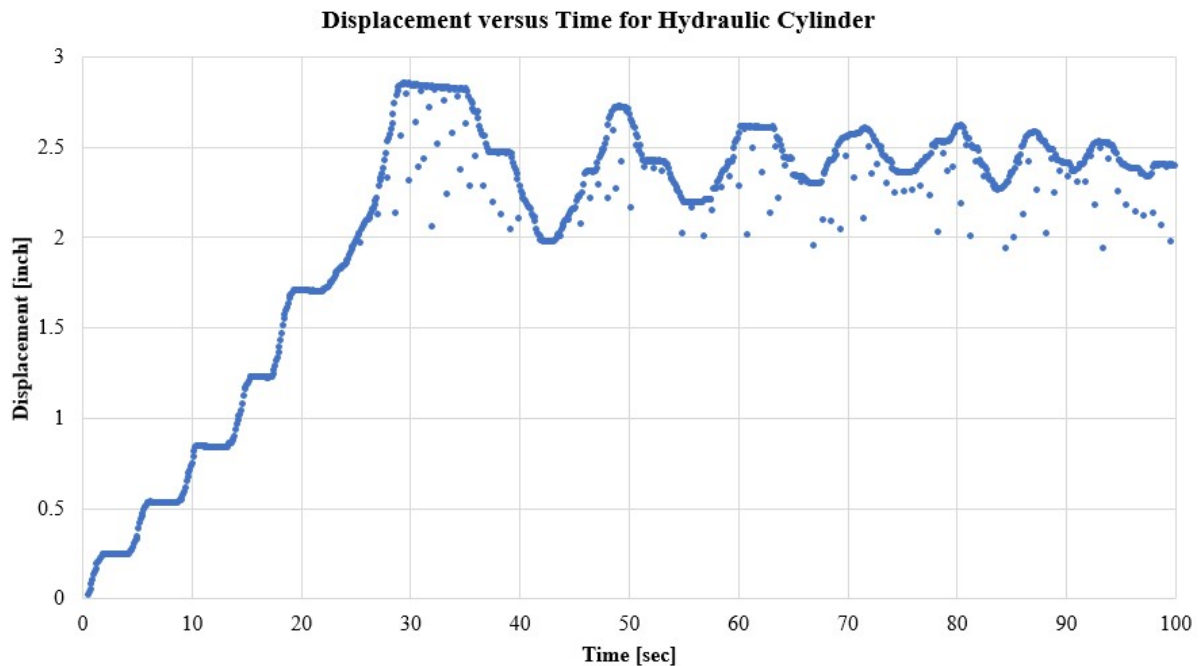

Figure 6. The EHA System Response in terms of Displacement vs Time.

IV. CONCLUSION

The typically very efficient EHA system results in a settling time of more than 90 seconds. This is far from ideal due to a necessity for quick speed maneuverability in flight controls. This is coupled with poor oscillation consistency by the rod. One possible reason for the poor settling time is the size of the system, requiring more fluid flow in order to reach acceptable system control. Another possible reason is the limit of the speed in which the Arduino can output the program. A different microcontroller may be more suitable for utilization in the EHA system. In future work it would be beneficial to explore more control algorithms than just the proportional term in PID. Other more complex methods may be more effective, such as Model Predictive Control (MPC), which relies on dynamic models to optimize both the current timeslot and future timeslots. Implementing a smaller overall system through the use of piping with smaller lengths and circumferences could lead to further improvements.

ACKNOWLEDGEMENT

I would like to acknowledge the undergraduate program office in the Industrial and Enterprise Systems Engineering department for the support of this study through the Research Experience for Undergraduates (REU) program. The guidance provided by the faculty advisor Dr. Pingfeng Wang and the senior graduate student Mr. Jiaxin (Josh) Wu is greatly appreciated.

REFERENCES

- [1] Botten S L, Whitley C R, King A D. Flight control actuation technology for next-generation all-electric aircraft, *Technology Review Journal — Millennium Issue*; 2000. p. 55-68.
- [2] Oh J Y, Jung GH, Lee G H, Park YJ, Song CS. Modeling and Characteristics Analysis of Single-Rod Hydraulic System Using Electro- Hydrostatic Actuator. *International Journal of Precision Engineering and Manufacturing*; 2012. Vol.13, p. 1445-1451.
- [3] Navatha, A., Bellad, K., Hiremath, S. S., & Karunanidhi, S. (2016). Dynamic Analysis of Electro Hydrostatic Actuation System. *Procedia Technology*, 25, 1289-1296.
- [4] Rahmat, M., Rozali, S., Wahab, N. A., Jusoff, K., & Zulfatman. (2010). Modeling and Controller Design of an Electro-Hydraulic Actuator System. *American Journal of Applied Sciences*, 7(8), 1100-1108.
- [5] Yuon, B. D., Hu, C., Wang, P., & Yoon, J. (2011). Resilience Allocation for Resilient Engineered System Design. *Journal of Institute of Control, Robotics and Systems*, 17(11), 1082-1089.
- [6] Rongjie, K., Zongxia, J., Shaoping, W., & Lisha, C. (2009). Design and Simulation of Electro-hydrostatic Actuator with a Built-in Power Regulator. *Chinese Journal of Aeronautics*, 22(6), 700-706.