



# Workforce Development of Young Professionals

Investing In Our Future



# Welcome Aspiring Engineers and Scientists!

Our goal is to show you  
the **possibilities available for  
students** interested in science,  
technology, engineering, and  
mathematics

---

Investing In Our Future

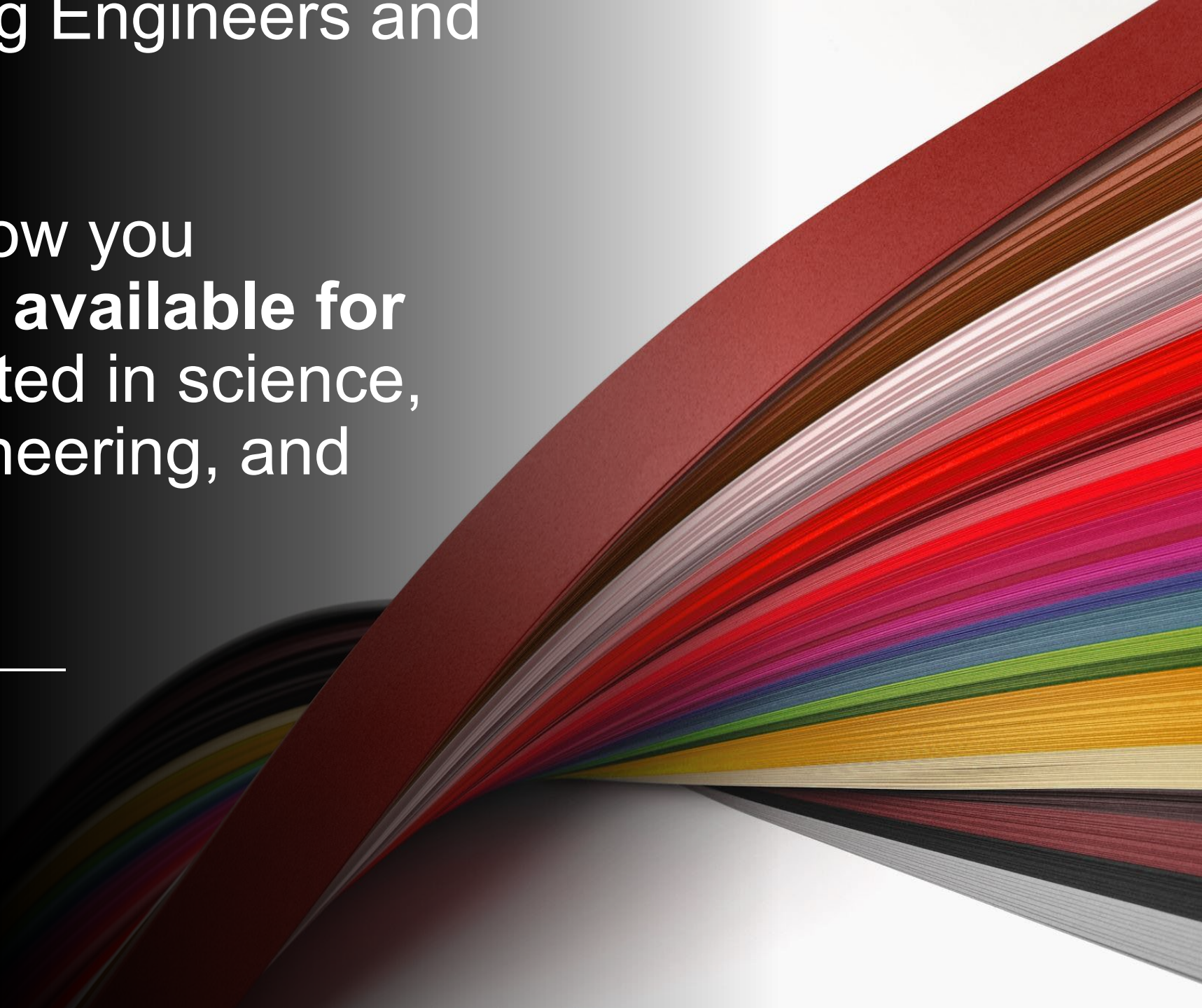



# Illinois Asphalt Pavement Association Scholarship Program

The purpose of the scholarship program is to:

- Promote knowledge of hot-mix asphalt (HMA) and HMA pavements;
- Enhance IAPA's relationship with Engineering and Construction schools throughout the state of Illinois; and
- Provide educational assistance to qualified students.

Minor research report on asphalt  
plus IAPA Annual Conference



# Illinois Asphalt Pavement Association Scholarship Program

Students at all these Illinois universities  
and colleges:

- University of Illinois, Urbana-Champaign
- University of Illinois, Chicago
- Bradley University
- Lake Land College
- Southern Illinois University, Carbondale
- Southern Illinois University, Edwardsville

Since 1984 = \$500k for 200 scholarships



# Illinois Department of Transportation



About IDOT ▾

Doing Business ▾

Travel Information ▾

Transportation System ▾

ENHANCED BY Google



[Home](#) / [About IDOT](#) / [Employment & Opportunities](#) / [Specialized Training](#)

## Highway Construction Careers Training Program

In collaboration with the Federal highway Administration, IDOT initiated the Highway Construction Careers Training Program (HCCTP) in an effort to provide training and skill-improvement opportunities to assure the increased participation of minority groups, disadvantaged persons and women in all phases of the highway construction industry. HCCTP emphasizes life-long learning and provides opportunities for further education and assistance to improve employability. The HCCTP is conducted at twelve community colleges throughout the state. The Department strongly encourages the prime contractor and their approved sub-contractors to hire minority, women and disadvantaged individuals from the HCCTP to help meet workforce and trainee goals. Graduates are well-trained and ready to become productive entry-level construction workers.

**IDOT Training Program Graduate On-the-Job Training Special Provision (TPG)**





We are passionate about the asphalt industry and cannot wait to meet the next generation of creative and innovative thinkers.

Investing In Our Future



# Plants

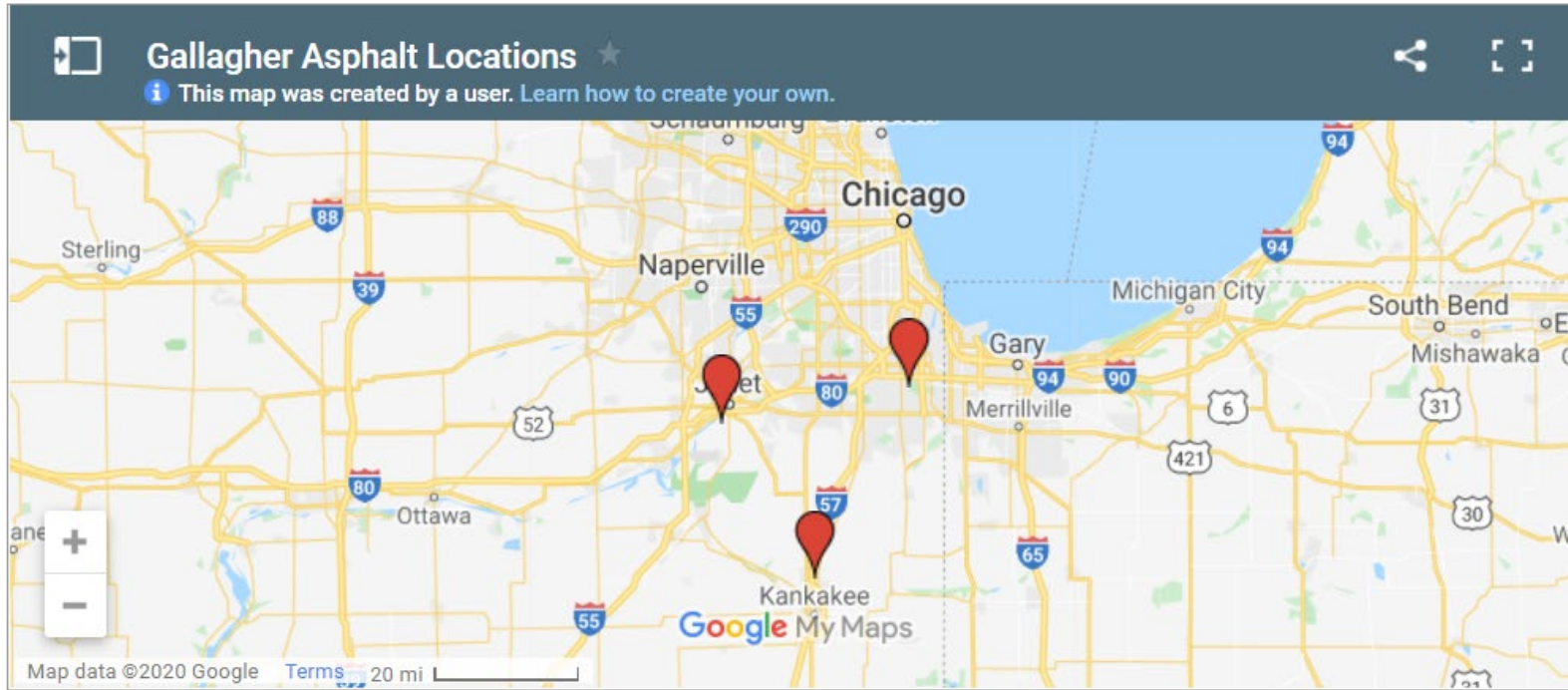

Thornton



Joliet

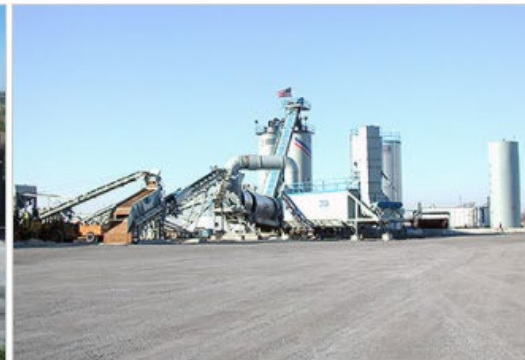

Bourbonnais





# Innovation

Apparatus for spreading hot asphalt

Patent No. 1,930,309

Serial No. 495,567

Patented October 10, 1933

By: James F. Gallagher

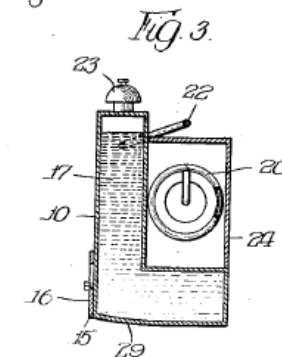
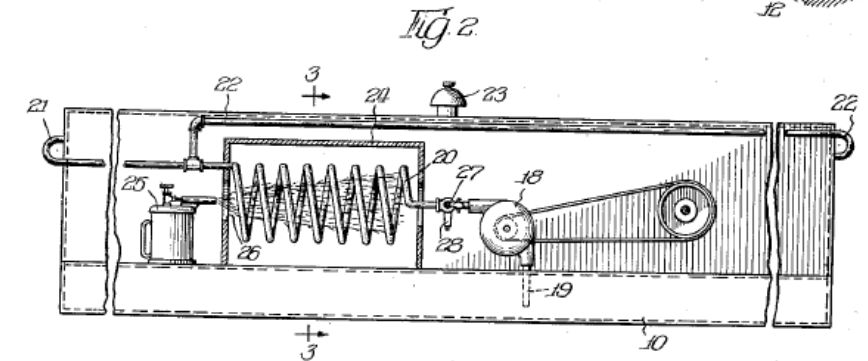
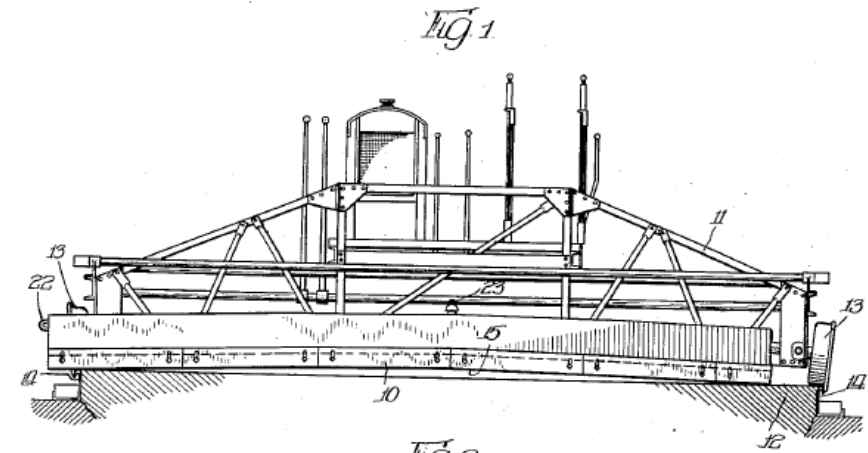

Inventor  
James F. Gallagher,  
By *Cromwell, Priest & Warden*  
attys.







Apprenticeships are not only valuable for our young people; they are a key way for all employers to invest in their workforce and provide the skills the economy needs both now and, in the future.

---

Investing In Our Future



Follow your passion







Sonia Martinez

[smarti@gallagherasphalt.com](mailto:smarti@gallagherasphalt.com)

708-922-1786

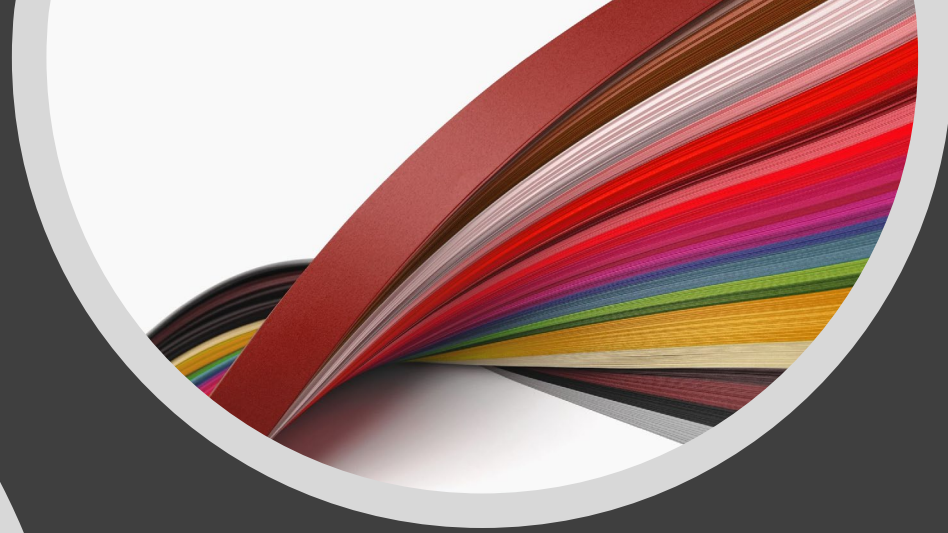

# A Unique Journey Through My Chosen Industry

Investing in Our Future

















NAPA  
DURING ACHIEVEMENT  
COMMENDATION

NAPA  
DIAMOND QUALITY  
COMMENDATION

NAPA  
DIAMOND PAVING  
COMMENDATION

Chicago Testing  
Laboratory, Inc.





HyWay

GENCO

GALIGH  
ASPH

NAPA  
DIAMOND AC  
COMMERCIAL



















119/19

$$= [(1.625' \times 2.5') + (0.625' \times 2.0')] \times 50$$

$$= (5.313 \text{ SF}) \times 50.0' = 265.65 \text{ CF}$$

4/22/19

$$= [(1.625' \times 2.5') + (0.625' \times 2.0')] \times 50$$

$$= (5.313 \text{ SF}) \times 50.0' = 265.65 \text{ CF}$$

4/23/19

$$= [(1.625' \times 2.5') + (0.625' \times 2.0')] \times 50$$

$$= (5.313 \text{ SF}) \times 50.0' = 265.65 \text{ CF}$$

4/24/19

$$= [(1.625' \times 2.5') + (0.625' \times 2.0')] \times 50$$

$$= (5.313 \text{ SF}) \times 50.0' = 265.65 \text{ CF}$$

4/25/19

$$= [(1.625' \times 2.5') + (0.625' \times 2.0')] \times 50$$

$$= (5.313 \text{ SF}) \times 50.0' = 265.65 \text{ CF}$$



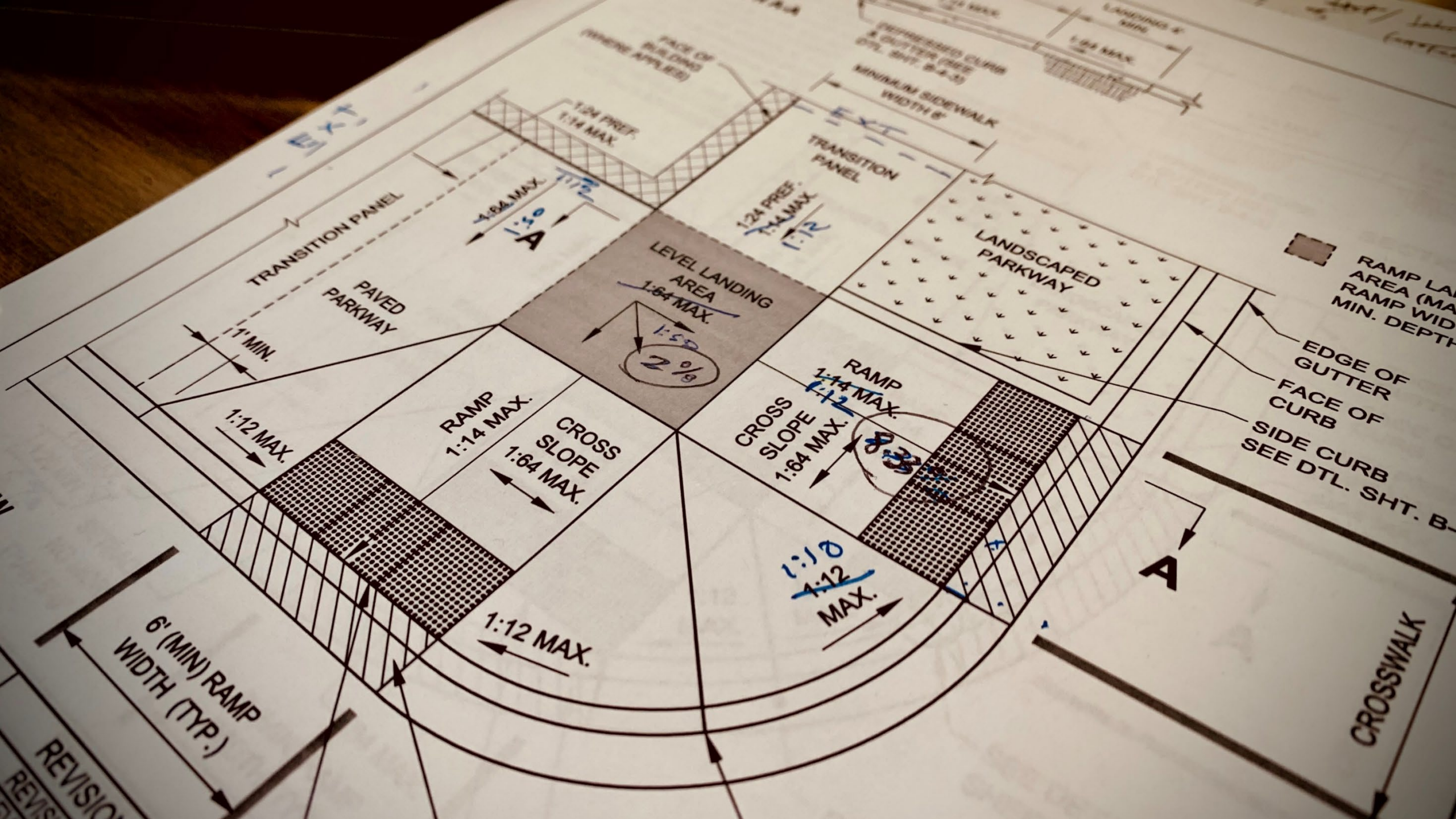





















Ryan Traficanto

[rmtraficanto@transystems.com](mailto:rmtraficanto@transystems.com)

815-790-2576





# Intern or Cooperative Education

Investing In Our Future



# Six Generations – Challenges or Thought Provoking?

## SIX THOUGHTS ON SIX LIVING GENERATIONS



- **GI Generation**—born 1901-1926, now age 90+ years of age
- **Silent Generation**—born 1927-1945, now 70-88 years old
- **Baby Boom Generation**—born 1946-1964, now 51-69 years old
- **Generation X**—born 1965-1980, now 35-50 years old
- **Generation Y (Millennials)**—born 1981-2000, now 15—34 years old
- **Generation Z**—born after 2001 and now in their formative years.



## Options and Opportunities

Industry Must Reach Out and Educate People as to the Opportunities in our Business

- Illinois Asphalt Pavement Association (IAPA) and universities and colleges
- Asphalt Pavement Association of Indiana (APAI) and Future Farmers of America (FFA)
- Job Fairs at High Schools and College
  - Explain diversity
  - Explain upward mobility

**Good Paying Jobs, Indoors / Outdoors:  
Engineers, Technicians, Chemists,  
Laborers, Operators, Managers, HR,  
Safety, Admin, Accountants**

**Investing in Our Future**



## Options and Opportunities

Future Education (Workforce Development) for Young Professionals:

- Agency Asphalt Training Programs
- World of Asphalt and Trade Show
- Asphalt Institute (Numerous including Bailey Method w/Wild Bill.)
- National Center for Asphalt Technology Professor's Training Course
- AsphaltPro Online Training

**Equipment Manufacturers:**  
Think ETYNRE, ROADTEC, CATERPILLAR, CEI, GENCOR, LIBRA, and the list goes on

**Investing in Our Future**



Knowledge and experience isn't nearly as important as 'want to'. Want to work, want to learn, want to contribute. You can't teach want to.

William J. Pine, P.E., (HRG), this morning as I was finalizing this presentation.

---



# Options and Opportunities



The screenshot shows the website header for the Illinois Department of Commerce & Economic Opportunity. The navigation menu includes: WHY ILLINOIS, EXPAND / RELOCATE, INVEST / EXPORT, ENTREPRENEURS, and WORKFORCE. Below the menu is a photo of two men in a warehouse setting, one in a white shirt and red suspenders, the other in a yellow shirt and cap. Below the photo is the breadcrumb: DCEO > Workforce Development. The main heading is 'Workforce Development'. Two logos are displayed: 'ILLINOIS workNet® CENTER americanjobcenter' and 'WIOA WORKS ILLINOIS'. At the bottom, a paragraph states: 'The Office of Employment and Training supports innovative workforce programs and career, training and employment services that connect employers to a highly skilled workforce. Providing assistance and resources for job seekers is central to Illinois' commitment to ensuring that businesses thrive in our state.'

Click below or the links on the right to view our programs and services:

- [Illinois workNet®](#)
- [WIOA Works Illinois](#)
- [Apprenticeship Illinois](#)
- [Trade Adjustment Assistance Program \(TAA\)](#)
- [Layoff Notices and Plant Closings \(WARN\)](#)
- [jobPrep Mobile App](#)
- [EPIC Initiatives](#)
- [WIOA Success Stories](#)
- [More Programs and Resources](#)
- [Illinois Workforce Development System \(IWDS\)](#)

**For more information contact:**

Office of Employment & Training  
Illinois Department of Commerce  
217.785.6006  
[workforce@illinois.gov](mailto:workforce@illinois.gov)

Investing in Our Future





Tim Murphy

[tmurphy@murphypavetech.com](mailto:tmurphy@murphypavetech.com)

773-874-9800



## SPONSORS

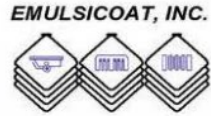

## EXHIBITORS





Thank You for Your Time...



We look forward to seeing you face to face and shaking hands in 2021 and virtually tomorrow