1. VECTORS AND FIELDS

Electromagnetics deals with the study of electric and magnetic “fields.” It is at once apparent that we need to familiarize ourselves with the concept of a “field,” and in particular with “electric” and “magnetic” fields. These fields are vector quantities and their behavior is governed by a set of laws known as “Maxwell’s equations.” The mathematical formulation of Maxwell’s equations and their subsequent application in our study of the elements of engineering electromagnetics require that we first learn the basic rules pertinent to mathematical manipulations involving vector quantities. With this goal in mind, we shall devote this chapter to vectors and fields.

We shall first study certain simple rules of vector algebra without the implication of a coordinate system and then introduce the Cartesian coordinate system, which is the coordinate system employed for the most part of our study in this book. After learning the vector algebraic rules, we shall turn our attention to a discussion of scalar and vector fields, static as well as time-varying, by means of some familiar examples. We shall devote particular attention to sinusoidally time-varying fields, scalar as well as vector, and to the phasor technique of dealing with sinusoidally time-varying quantities. With this general introduction to vectors and fields, we shall then devote the remainder of the chapter to an introduction of the electric and magnetic field concepts, from considerations of the experimental laws of Coulomb and Ampere.

1.1 VECTOR ALGEBRA

In the study of elementary physics we come across several quantities such as mass, temperature, velocity, acceleration, force, and charge. Some of these quantities have associated with them not only a magnitude but also a direction in space whereas others are characterized by magnitude only. The former class of quantities are known as “vectors” and the latter class of quantities are known as “scalars.” Mass, temperature, and charge are scalars whereas velocity, acceleration, and force are vectors. Other examples are voltage and current for scalars and electric and magnetic fields for vectors.

Vector quantities are represented by boldface roman type symbols, e.g., \mathbf{A} , in order to distinguish them from scalar quantities which are represented by lightface italic type symbols, e.g., A . Graphically, a vector, say \mathbf{A} , is represented by a straight line with an arrowhead pointing in the direction of \mathbf{A} and having a length proportional to the magnitude of \mathbf{A} , denoted $|\mathbf{A}|$ or simply A . Figures 1.1(a)–(d) show four vectors drawn to the same scale. If

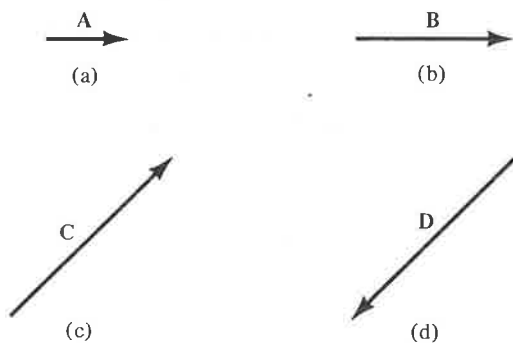

Figure 1.1. Graphical representation of vectors.

the top of the page represents north, then vectors \mathbf{A} and \mathbf{B} are directed eastward with the magnitude of \mathbf{B} being twice that of \mathbf{A} . Vector \mathbf{C} is directed toward the northeast and has a magnitude three times that of \mathbf{A} . Vector \mathbf{D} is directed toward the southwest and has a magnitude equal to that of \mathbf{C} . Since \mathbf{C} and \mathbf{D} are equal in magnitude but opposite in direction, one is the negative of the other.

Since a vector may have in general an arbitrary orientation in three dimensions, we need to define a set of three reference directions at each and every point in space in terms of which we can describe vectors drawn at that point. It is convenient to choose these three reference directions to be mutually

orthogonal as, for example, east, north and upward or the three contiguous edges of a rectangular room. Thus let us consider three mutually orthogonal reference directions and direct "unit vectors" along the three directions as shown, for example, in Fig. 1.2(a). A unit vector has magnitude unity. We shall represent a unit vector by the symbol \mathbf{i} and use a subscript to denote its direction. We shall denote the three directions by subscripts 1, 2, and 3. We note that for a fixed orientation of \mathbf{i}_1 , two combinations are possible for the orientations of \mathbf{i}_2 and \mathbf{i}_3 , as shown in Figs. 1.2(a) and (b). If we take a right-hand screw and turn it from \mathbf{i}_1 to \mathbf{i}_2 through the 90° -angle, it progresses in the direction of \mathbf{i}_3 in Fig. 1.2(a) but opposite to the direction of \mathbf{i}_3 in Fig. 1.2(b). Alternatively, a left-hand screw when turned from \mathbf{i}_1 to \mathbf{i}_2 in Fig. 1.2(b) will progress in the direction of \mathbf{i}_3 . Hence the set of unit vectors in Fig. 1.2(a) corresponds to a right-handed system whereas the set in Fig. 1.2(b) corresponds to a left-handed system. We shall work consistently with the right-handed system.

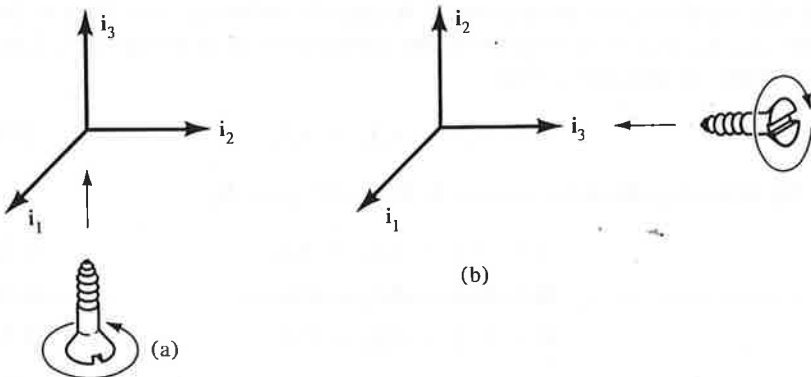

Figure 1.2. (a) Set of three orthogonal unit vectors in a right-handed system. (b) Set of three orthogonal unit vectors in a left-handed system.

A vector of magnitude different from unity along any of the reference directions can be represented in terms of the unit vector along that direction. Thus $4\mathbf{i}_1$ represents a vector of magnitude 4 units in the direction of \mathbf{i}_1 , $6\mathbf{i}_2$ represents a vector of magnitude 6 units in the direction of \mathbf{i}_2 , and $-2\mathbf{i}_3$ represents a vector of magnitude 2 units in the direction opposite to that of \mathbf{i}_3 , as shown in Fig. 1.3. Two vectors are added by placing the beginning of the second vector at the tip of the first vector and then drawing the sum vector from the beginning of the first vector to the tip of the second vector. Thus to add $4\mathbf{i}_1$ and $6\mathbf{i}_2$, we simply slide $6\mathbf{i}_2$ without changing its direction until its beginning coincides with the tip of $4\mathbf{i}_1$ and then draw the vector $4\mathbf{i}_1 + 6\mathbf{i}_2$ from the beginning of $4\mathbf{i}_1$ to the tip of $6\mathbf{i}_2$, as shown in Fig. 1.3. By adding $-2\mathbf{i}_3$ to this vector $4\mathbf{i}_1 + 6\mathbf{i}_2$ in a similar manner, we obtain the vector

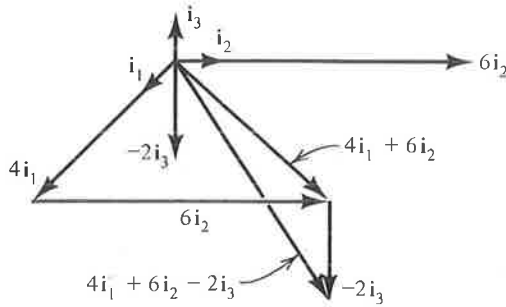

Figure 1.3. Graphical addition of vectors.

$(4\mathbf{i}_1 + 6\mathbf{i}_2 - 2\mathbf{i}_3)$, as shown in Fig. 1.3. We note that the magnitude of $(4\mathbf{i}_1 + 6\mathbf{i}_2)$ is $\sqrt{4^2 + 6^2}$ or 7.211 and that the magnitude of $(4\mathbf{i}_1 + 6\mathbf{i}_2 - 2\mathbf{i}_3)$ is $\sqrt{4^2 + 6^2 + 2^2}$ or 7.483. Conversely to the foregoing discussion, a vector \mathbf{A} at a given point is simply the superposition of three vectors $A_1\mathbf{i}_1$, $A_2\mathbf{i}_2$, and $A_3\mathbf{i}_3$ which are the projections of \mathbf{A} onto the reference directions at that point. A_1 , A_2 , and A_3 are known as the components of \mathbf{A} along the 1, 2, and 3 directions, respectively. Thus

$$\mathbf{A} = A_1\mathbf{i}_1 + A_2\mathbf{i}_2 + A_3\mathbf{i}_3 \quad (1.1)$$

We now consider three vectors \mathbf{A} , \mathbf{B} , and \mathbf{C} given by

$$\mathbf{A} = A_1\mathbf{i}_1 + A_2\mathbf{i}_2 + A_3\mathbf{i}_3 \quad (1.2a)$$

$$\mathbf{B} = B_1\mathbf{i}_1 + B_2\mathbf{i}_2 + B_3\mathbf{i}_3 \quad (1.2b)$$

$$\mathbf{C} = C_1\mathbf{i}_1 + C_2\mathbf{i}_2 + C_3\mathbf{i}_3 \quad (1.2c)$$

at a point and discuss several algebraic operations involving vectors as follows.

VECTOR ADDITION AND SUBTRACTION: Since a given pair of like components of two vectors are parallel, addition of two vectors consists simply of adding the three pairs of like components of the vectors. Thus

$$\begin{aligned} \mathbf{A} + \mathbf{B} &= (A_1\mathbf{i}_1 + A_2\mathbf{i}_2 + A_3\mathbf{i}_3) + (B_1\mathbf{i}_1 + B_2\mathbf{i}_2 + B_3\mathbf{i}_3) \\ &= (A_1 + B_1)\mathbf{i}_1 + (A_2 + B_2)\mathbf{i}_2 + (A_3 + B_3)\mathbf{i}_3 \end{aligned} \quad (1.3)$$

Vector subtraction is a special case of addition. Thus

$$\begin{aligned} \mathbf{B} - \mathbf{C} &= \mathbf{B} + (-\mathbf{C}) = (B_1\mathbf{i}_1 + B_2\mathbf{i}_2 + B_3\mathbf{i}_3) + (-C_1\mathbf{i}_1 - C_2\mathbf{i}_2 - C_3\mathbf{i}_3) \\ &= (B_1 - C_1)\mathbf{i}_1 + (B_2 - C_2)\mathbf{i}_2 + (B_3 - C_3)\mathbf{i}_3 \end{aligned} \quad (1.4)$$

MULTIPLICATION AND DIVISION BY A SCALAR: Multiplication of a vector \mathbf{A} by a scalar m is the same as repeated addition of the vector. Thus

$$m\mathbf{A} = m(A_1\mathbf{i}_1 + A_2\mathbf{i}_2 + A_3\mathbf{i}_3) = mA_1\mathbf{i}_1 + mA_2\mathbf{i}_2 + mA_3\mathbf{i}_3 \quad (1.5)$$

Division by a scalar is a special case of multiplication by a scalar. Thus

$$\frac{\mathbf{B}}{n} = \frac{1}{n}(\mathbf{B}) = \frac{B_1}{n}\mathbf{i}_1 + \frac{B_2}{n}\mathbf{i}_2 + \frac{B_3}{n}\mathbf{i}_3 \quad (1.6)$$

MAGNITUDE OF A VECTOR: From the construction of Fig. 1.3 and the associated discussion, we have

$$|\mathbf{A}| = |A_1\mathbf{i}_1 + A_2\mathbf{i}_2 + A_3\mathbf{i}_3| = \sqrt{A_1^2 + A_2^2 + A_3^2} \quad (1.7)$$

UNIT VECTOR ALONG \mathbf{A} : The unit vector \mathbf{i}_A has a magnitude equal to unity but its direction is the same as that of \mathbf{A} . Hence

$$\begin{aligned} \mathbf{i}_A &= \frac{\mathbf{A}}{|\mathbf{A}|} = \frac{A_1\mathbf{i}_1 + A_2\mathbf{i}_2 + A_3\mathbf{i}_3}{\sqrt{A_1^2 + A_2^2 + A_3^2}} \\ &= \frac{A_1}{\sqrt{A_1^2 + A_2^2 + A_3^2}}\mathbf{i}_1 + \frac{A_2}{\sqrt{A_1^2 + A_2^2 + A_3^2}}\mathbf{i}_2 + \frac{A_3}{\sqrt{A_1^2 + A_2^2 + A_3^2}}\mathbf{i}_3 \end{aligned} \quad (1.8)$$

SCALAR OR DOT PRODUCT OF TWO VECTORS: The scalar or dot product of two vectors \mathbf{A} and \mathbf{B} is a scalar quantity equal to the product of the magnitudes of \mathbf{A} and \mathbf{B} and the cosine of the angle between \mathbf{A} and \mathbf{B} . It is represented by a dot between \mathbf{A} and \mathbf{B} . Thus if α is the angle between \mathbf{A} and \mathbf{B} , then

$$\mathbf{A} \cdot \mathbf{B} = |\mathbf{A}| |\mathbf{B}| \cos \alpha = AB \cos \alpha \quad (1.9)$$

For the unit vectors $\mathbf{i}_1, \mathbf{i}_2, \mathbf{i}_3$, we have

$$\mathbf{i}_1 \cdot \mathbf{i}_1 = 1 \quad \mathbf{i}_1 \cdot \mathbf{i}_2 = 0 \quad \mathbf{i}_1 \cdot \mathbf{i}_3 = 0 \quad (1.10a)$$

$$\mathbf{i}_2 \cdot \mathbf{i}_1 = 0 \quad \mathbf{i}_2 \cdot \mathbf{i}_2 = 1 \quad \mathbf{i}_2 \cdot \mathbf{i}_3 = 0 \quad (1.10b)$$

$$\mathbf{i}_3 \cdot \mathbf{i}_1 = 0 \quad \mathbf{i}_3 \cdot \mathbf{i}_2 = 0 \quad \mathbf{i}_3 \cdot \mathbf{i}_3 = 1 \quad (1.10c)$$

By noting that $\mathbf{A} \cdot \mathbf{B} = A(B \cos \alpha) = B(A \cos \alpha)$, we observe that the dot product operation consists of multiplying the magnitude of one vector by the scalar obtained by projecting the second vector onto the first vector as shown in Figs. 1.4(a) and (b). The dot product operation is commutative since

$$\mathbf{B} \cdot \mathbf{A} = BA \cos \alpha = AB \cos \alpha = \mathbf{A} \cdot \mathbf{B} \quad (1.11)$$

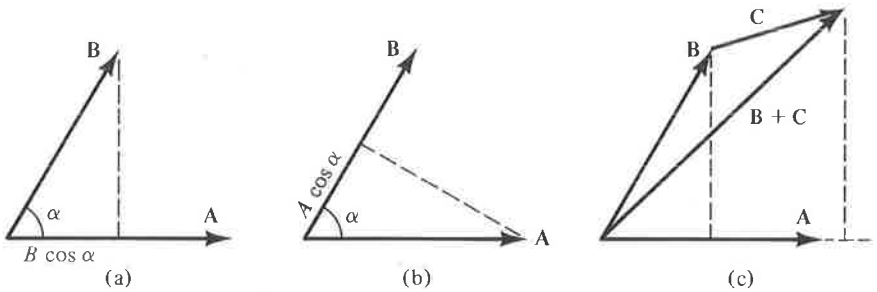

Figure 1.4. (a) and (b) For showing that the dot product of two vectors **A** and **B** is the product of the magnitude of one vector and the projection of the second vector onto the first vector. (c) For proving the distributive property of the dot product operation.

The distributive property also holds for the dot product as can be seen from the construction of Fig. 1.4(c), which illustrates that the projection of **B** + **C** onto **A** is equal to the sum of the projections of **B** and **C** onto **A**. Thus

$$\mathbf{A} \cdot (\mathbf{B} + \mathbf{C}) = \mathbf{A} \cdot \mathbf{B} + \mathbf{A} \cdot \mathbf{C} \quad (1.12)$$

Using this property, and the relationships (1.10a)–(1.10c), we have

$$\begin{aligned} \mathbf{A} \cdot \mathbf{B} &= (A_1 \mathbf{i}_1 + A_2 \mathbf{i}_2 + A_3 \mathbf{i}_3) \cdot (B_1 \mathbf{i}_1 + B_2 \mathbf{i}_2 + B_3 \mathbf{i}_3) \\ &= A_1 \mathbf{i}_1 \cdot B_1 \mathbf{i}_1 + A_1 \mathbf{i}_1 \cdot B_2 \mathbf{i}_2 + A_1 \mathbf{i}_1 \cdot B_3 \mathbf{i}_3 \\ &\quad + A_2 \mathbf{i}_2 \cdot B_1 \mathbf{i}_1 + A_2 \mathbf{i}_2 \cdot B_2 \mathbf{i}_2 + A_2 \mathbf{i}_2 \cdot B_3 \mathbf{i}_3 \\ &\quad + A_3 \mathbf{i}_3 \cdot B_1 \mathbf{i}_1 + A_3 \mathbf{i}_3 \cdot B_2 \mathbf{i}_2 + A_3 \mathbf{i}_3 \cdot B_3 \mathbf{i}_3 \\ &= A_1 B_1 + A_2 B_2 + A_3 B_3 \end{aligned} \quad (1.13)$$

Thus the dot product of two vectors is the sum of the products of the like components of the two vectors.

VECTOR OR CROSS PRODUCT OF TWO VECTORS: The vector or cross product of two vectors **A** and **B** is a vector quantity whose magnitude is equal to the product of the magnitudes of **A** and **B** and the sine of the angle α between **A** and **B** and whose direction is the direction of advance of a right-hand screw as it is turned from **A** to **B** through the angle α , as shown in Fig. 1.5. It is represented by a cross between **A** and **B**. Thus if \mathbf{i}_N is the unit vector in the direction of advance of the right-hand screw, then

$$\mathbf{A} \times \mathbf{B} = |\mathbf{A}| |\mathbf{B}| \sin \alpha \mathbf{i}_N = AB \sin \alpha \mathbf{i}_N \quad (1.14)$$

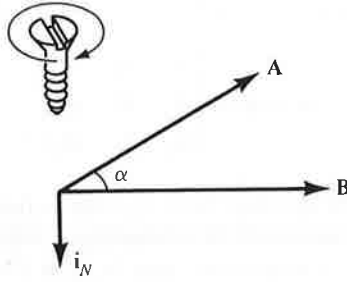

Figure 1.5. The cross product operation $\mathbf{A} \times \mathbf{B}$.

For the unit vectors $\mathbf{i}_1, \mathbf{i}_2, \mathbf{i}_3$, we have

$$\mathbf{i}_1 \times \mathbf{i}_1 = 0 \quad \mathbf{i}_1 \times \mathbf{i}_2 = \mathbf{i}_3 \quad \mathbf{i}_1 \times \mathbf{i}_3 = -\mathbf{i}_2 \quad (1.15a)$$

$$\mathbf{i}_2 \times \mathbf{i}_1 = -\mathbf{i}_3 \quad \mathbf{i}_2 \times \mathbf{i}_2 = 0 \quad \mathbf{i}_2 \times \mathbf{i}_3 = \mathbf{i}_1 \quad (1.15b)$$

$$\mathbf{i}_3 \times \mathbf{i}_1 = \mathbf{i}_2 \quad \mathbf{i}_3 \times \mathbf{i}_2 = -\mathbf{i}_1 \quad \mathbf{i}_3 \times \mathbf{i}_3 = 0 \quad (1.15c)$$

Note that the cross product of identical vectors is zero. If we arrange the unit vectors in the manner $\mathbf{i}_1 \mathbf{i}_2 \mathbf{i}_3 \mathbf{i}_1 \mathbf{i}_2$ and then go forward, the cross product of any two successive unit vectors is equal to the following unit vector, but if we go backward, the cross product of any two successive unit vectors is the negative of the following unit vector.

The cross product operation is not commutative since

$$\mathbf{B} \times \mathbf{A} = |\mathbf{B}| |\mathbf{A}| \sin \alpha (-\mathbf{i}_N) = -AB \sin \alpha \mathbf{i}_N = -\mathbf{A} \times \mathbf{B} \quad (1.16)$$

The distributive property holds for the cross product (we shall prove this later in this section) so that

$$\mathbf{A} \times (\mathbf{B} + \mathbf{C}) = \mathbf{A} \times \mathbf{B} + \mathbf{A} \times \mathbf{C} \quad (1.17)$$

Using this property and the relationships (1.15a)–(1.15c), we obtain

$$\begin{aligned} \mathbf{A} \times \mathbf{B} &= (A_1 \mathbf{i}_1 + A_2 \mathbf{i}_2 + A_3 \mathbf{i}_3) \times (B_1 \mathbf{i}_1 + B_2 \mathbf{i}_2 + B_3 \mathbf{i}_3) \\ &= A_1 \mathbf{i}_1 \times B_1 \mathbf{i}_1 + A_1 \mathbf{i}_1 \times B_2 \mathbf{i}_2 + A_1 \mathbf{i}_1 \times B_3 \mathbf{i}_3 \\ &\quad + A_2 \mathbf{i}_2 \times B_1 \mathbf{i}_1 + A_2 \mathbf{i}_2 \times B_2 \mathbf{i}_2 + A_2 \mathbf{i}_2 \times B_3 \mathbf{i}_3 \\ &\quad + A_3 \mathbf{i}_3 \times B_1 \mathbf{i}_1 + A_3 \mathbf{i}_3 \times B_2 \mathbf{i}_2 + A_3 \mathbf{i}_3 \times B_3 \mathbf{i}_3 \\ &= A_1 B_2 \mathbf{i}_3 - A_1 B_3 \mathbf{i}_2 - A_2 B_1 \mathbf{i}_3 + A_2 B_3 \mathbf{i}_1 \\ &\quad + A_3 B_1 \mathbf{i}_2 - A_3 B_2 \mathbf{i}_1 \\ &= (A_2 B_3 - A_3 B_2) \mathbf{i}_1 + (A_3 B_1 - A_1 B_3) \mathbf{i}_2 \\ &\quad + (A_1 B_2 - A_2 B_1) \mathbf{i}_3 \end{aligned} \quad (1.18)$$

This can be expressed in determinant form in the manner

$$\mathbf{A} \times \mathbf{B} = \begin{vmatrix} \mathbf{i}_1 & \mathbf{i}_2 & \mathbf{i}_3 \\ A_1 & A_2 & A_3 \\ B_1 & B_2 & B_3 \end{vmatrix} \quad (1.19)$$

A triple cross product involves three vectors in two cross product operations. Caution must be exercised in evaluating a triple cross product since the order of evaluation is important, that is, $\mathbf{A} \times (\mathbf{B} \times \mathbf{C})$ is not equal to $(\mathbf{A} \times \mathbf{B}) \times \mathbf{C}$. This can be illustrated by means of a simple example involving unit vectors. Thus if $\mathbf{A} = \mathbf{i}_1$, $\mathbf{B} = \mathbf{i}_1$, and $\mathbf{C} = \mathbf{i}_2$, then

$$\mathbf{A} \times (\mathbf{B} \times \mathbf{C}) = \mathbf{i}_1 \times (\mathbf{i}_1 \times \mathbf{i}_2) = \mathbf{i}_1 \times \mathbf{i}_3 = -\mathbf{i}_2$$

whereas

$$(\mathbf{A} \times \mathbf{B}) \times \mathbf{C} = (\mathbf{i}_1 \times \mathbf{i}_1) \times \mathbf{i}_2 = \mathbf{0} \times \mathbf{i}_2 = \mathbf{0}$$

SCALAR TRIPLE PRODUCT: The scalar triple product involves three vectors in a dot product operation and a cross product operation as, for example, $\mathbf{A} \cdot \mathbf{B} \times \mathbf{C}$. It is not necessary to include parentheses since this quantity can be evaluated in only one manner, that is, by evaluating $\mathbf{B} \times \mathbf{C}$ first and then dotting the resulting vector with \mathbf{A} . It is meaningless to try to evaluate the dot product first since it results in a scalar quantity and hence we cannot proceed any further. From (1.13) and (1.19), we have

$$\mathbf{A} \cdot \mathbf{B} \times \mathbf{C} = (A_1\mathbf{i}_1 + A_2\mathbf{i}_2 + A_3\mathbf{i}_3) \cdot \begin{vmatrix} \mathbf{i}_1 & \mathbf{i}_2 & \mathbf{i}_3 \\ B_1 & B_2 & B_3 \\ C_1 & C_2 & C_3 \end{vmatrix} = \begin{vmatrix} A_1 & A_2 & A_3 \\ B_1 & B_2 & B_3 \\ C_1 & C_2 & C_3 \end{vmatrix} \quad (1.20)$$

Since the value of the determinant on the right side of (1.20) remains unchanged if the rows are interchanged in a cyclical manner,

$$\mathbf{A} \cdot \mathbf{B} \times \mathbf{C} = \mathbf{B} \cdot \mathbf{C} \times \mathbf{A} = \mathbf{C} \cdot \mathbf{A} \times \mathbf{B} \quad (1.21)$$

We shall now show that the distributive law holds for the cross product operation by using (1.21). Thus let us consider $\mathbf{A} \times (\mathbf{B} + \mathbf{C})$. Then if \mathbf{D} is any arbitrary vector, we have

$$\begin{aligned} \mathbf{D} \cdot \mathbf{A} \times (\mathbf{B} + \mathbf{C}) &= (\mathbf{B} + \mathbf{C}) \cdot (\mathbf{D} \times \mathbf{A}) = \mathbf{B} \cdot (\mathbf{D} \times \mathbf{A}) + \mathbf{C} \cdot (\mathbf{D} \times \mathbf{A}) \\ &= \mathbf{D} \cdot \mathbf{A} \times \mathbf{B} + \mathbf{D} \cdot \mathbf{A} \times \mathbf{C} = \mathbf{D} \cdot (\mathbf{A} \times \mathbf{B} + \mathbf{A} \times \mathbf{C}) \end{aligned} \quad (1.22)$$

where we have used the distributive property of the dot product operation. Since (1.22) holds for any \mathbf{D} , it follows that

$$\mathbf{A} \times (\mathbf{B} + \mathbf{C}) = \mathbf{A} \times \mathbf{B} + \mathbf{A} \times \mathbf{C}.$$

Example 1.1. Given three vectors

$$\mathbf{A} = \mathbf{i}_1 + \mathbf{i}_2$$

$$\mathbf{B} = \mathbf{i}_1 + 2\mathbf{i}_2 - 2\mathbf{i}_3$$

$$\mathbf{C} = \mathbf{i}_2 + 2\mathbf{i}_3$$

let us carry out several of the vector algebraic operations.

$$(a) \mathbf{A} + \mathbf{B} = (\mathbf{i}_1 + \mathbf{i}_2) + (\mathbf{i}_1 + 2\mathbf{i}_2 - 2\mathbf{i}_3) = 2\mathbf{i}_1 + 3\mathbf{i}_2 - 2\mathbf{i}_3$$

$$(b) \mathbf{B} - \mathbf{C} = (\mathbf{i}_1 + 2\mathbf{i}_2 - 2\mathbf{i}_3) - (\mathbf{i}_2 + 2\mathbf{i}_3) = \mathbf{i}_1 + \mathbf{i}_2 - 4\mathbf{i}_3$$

$$(c) 4\mathbf{C} = 4(\mathbf{i}_2 + 2\mathbf{i}_3) = 4\mathbf{i}_2 + 8\mathbf{i}_3$$

$$(d) |\mathbf{B}| = |\mathbf{i}_1 + 2\mathbf{i}_2 - 2\mathbf{i}_3| = \sqrt{(1)^2 + (2)^2 + (-2)^2} = 3$$

$$(e) \mathbf{i}_B = \frac{\mathbf{B}}{|\mathbf{B}|} = \frac{\mathbf{i}_1 + 2\mathbf{i}_2 - 2\mathbf{i}_3}{3} = \frac{1}{3}\mathbf{i}_1 + \frac{2}{3}\mathbf{i}_2 - \frac{2}{3}\mathbf{i}_3$$

$$(f) \mathbf{A} \cdot \mathbf{B} = (\mathbf{i}_1 + \mathbf{i}_2) \cdot (\mathbf{i}_1 + 2\mathbf{i}_2 - 2\mathbf{i}_3) = (1)(1) + (1)(2) + (0)(-2) = 3$$

$$(g) \mathbf{A} \times \mathbf{B} = \begin{vmatrix} \mathbf{i}_1 & \mathbf{i}_2 & \mathbf{i}_3 \\ 1 & 1 & 0 \\ 1 & 2 & -2 \end{vmatrix} = (-2 - 0)\mathbf{i}_1 + (0 + 2)\mathbf{i}_2 + (2 - 1)\mathbf{i}_3 \\ = -2\mathbf{i}_1 + 2\mathbf{i}_2 + \mathbf{i}_3$$

$$(h) (\mathbf{A} \times \mathbf{B}) \times \mathbf{C} = \begin{vmatrix} \mathbf{i}_1 & \mathbf{i}_2 & \mathbf{i}_3 \\ -2 & 2 & 1 \\ 0 & 1 & 2 \end{vmatrix} = 3\mathbf{i}_1 + 4\mathbf{i}_2 - 2\mathbf{i}_3$$

$$(i) \mathbf{A} \cdot \mathbf{B} \times \mathbf{C} = \begin{vmatrix} 1 & 1 & 0 \\ 1 & 2 & -2 \\ 0 & 1 & 2 \end{vmatrix} = (1)(6) + (1)(-2) + (0)(1) = 4 \quad \blacksquare$$

1.2 CARTESIAN COORDINATE SYSTEM

In the previous section we introduced the technique of expressing a vector at a point in space in terms of its component vectors along a set of three mutually orthogonal directions defined by three mutually orthogonal unit vectors at that point. Now in order to relate vectors at one point in space to vectors at another point in space, we must define the set of three reference directions at each and every point in space. To do this in a systematic manner, we need to use a coordinate system. Although there are several different

coordinate systems, we shall use for the most part of our study the simplest of these, namely, the Cartesian coordinate system, also known as the “rectangular coordinate system,” to keep the geometry simple and yet sufficient to learn many of the elements of engineering electromagnetics. We shall, however, find it necessary in a few cases to resort to the use of cylindrical and spherical coordinate systems. Hence a discussion of these coordinate systems is included in Appendix A. In this section we introduce the Cartesian coordinate system.

The Cartesian coordinate system is defined by a set of three mutually orthogonal planes as shown in Fig. 1.6(a). The point at which the three planes intersect is known as the origin O . The origin is the reference point relative to which we locate any other point in space. Each pair of planes intersects in a straight line. Hence the three planes define a set of three straight lines which form the coordinate axes. These coordinate axes are denoted as the x , y , and z axes. Values of x , y , and z are measured from the origin and hence the coordinates of the origin are $(0, 0, 0)$, that is, $x = 0$, $y = 0$, and $z = 0$. Directions in which values of x , y , and z increase along the respective coordinate axes are indicated by arrowheads. The same set of three directions is used to erect a set of three unit vectors, denoted \mathbf{i}_x , \mathbf{i}_y , and \mathbf{i}_z , as shown in Fig. 1.6(a), for the purpose of describing vectors drawn at the origin. Note that the positive x , y , and z directions are chosen such that they form a right-handed system, that is, a system for which $\mathbf{i}_x \times \mathbf{i}_y = \mathbf{i}_z$.

On one of the three planes, namely, the yz plane, the value of x is constant and equal to zero, its value at the origin, since movement on this plane does not require any movement in the x direction. Similarly, on the zx plane the value of y is constant and equal to zero, and on the xy plane the value of z is constant and equal to zero. Any point other than the origin is now given by the intersection of three planes obtained by incrementing the values of the coordinates by appropriate amounts. For example, by displacing the $x = 0$ plane by 2 units in the positive x direction, the $y = 0$ plane by 5 units in the positive y direction, and the $z = 0$ plane by 4 units in the positive z direction, we obtain the planes $x = 2$, $y = 5$, and $z = 4$, respectively, which intersect at the point $(2, 5, 4)$ as shown in Fig. 1.6(b). The intersections of pairs of these planes define three straight lines along which we can erect the unit vectors \mathbf{i}_x , \mathbf{i}_y , and \mathbf{i}_z toward the directions of increasing values of x , y , and z , respectively, for the purpose of describing vectors drawn at that point. These unit vectors are parallel to the corresponding unit vectors drawn at the origin, as can be seen from Fig. 1.6(b). The same is true for any point in space in the Cartesian coordinate system. Thus each one of the three unit vectors in the Cartesian coordinate system has the same direction at all points and hence it is uniform. This behavior does not, however, hold for all unit vectors in the cylindrical and spherical coordinate systems.

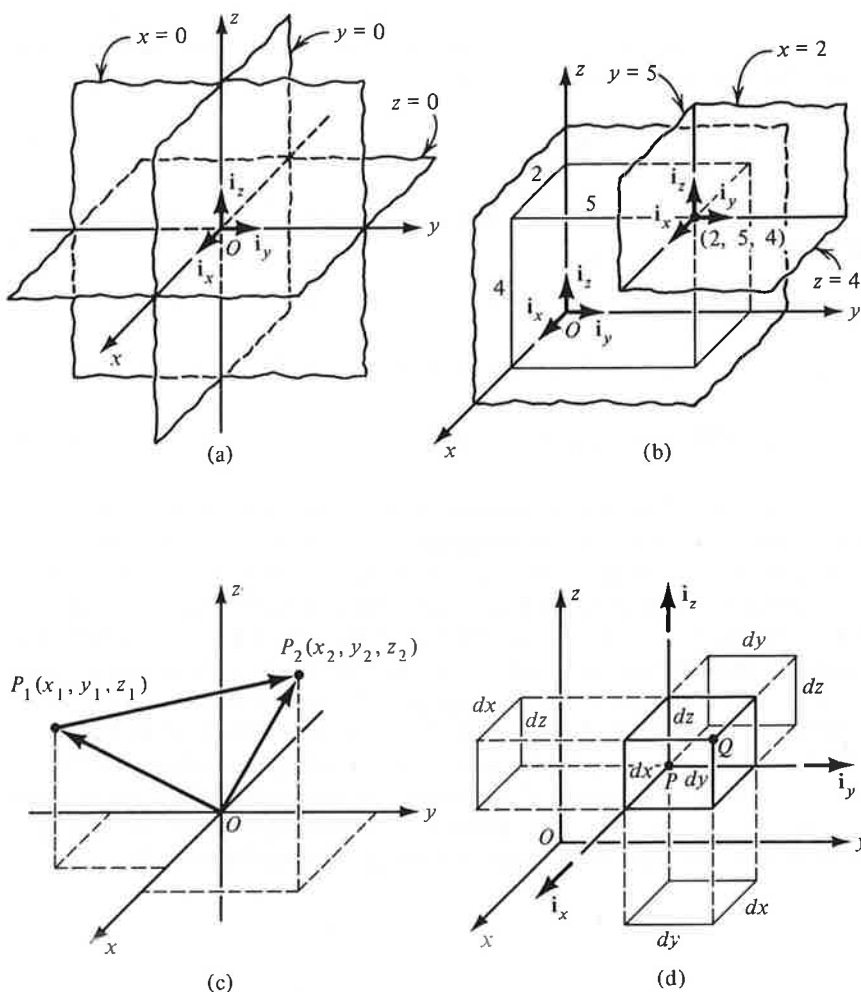

Figure 1.6. Cartesian coordinate system. (a) The three orthogonal planes defining the coordinate system. (b) Unit vectors at an arbitrary point. (c) Vector from one arbitrary point to another arbitrary point. (d) Differential lengths, surfaces, and volume formed by incrementing the coordinates.

It is now a simple matter to apply what we have learned in Sec. 1.1 to vectors in Cartesian coordinates. All we need to do is to replace the subscripts 1, 2, and 3 for the unit vectors and the components along the unit vectors by the subscripts x , y , and z , respectively, and also utilize the property that \mathbf{i}_x , \mathbf{i}_y , and \mathbf{i}_z are uniform vectors. Thus let us, for example, obtain the expres-

sion for the vector drawn from point $P_1(x_1, y_1, z_1)$ to point $P_2(x_2, y_2, z_2)$, as shown in Fig. 1.6(c). To do this, we note that the vector drawn from the origin to the point P_1 , that is, \mathbf{OP}_1 is given by

$$\mathbf{OP}_1 = x_1\mathbf{i}_x + y_1\mathbf{i}_y + z_1\mathbf{i}_z \quad (1.23)$$

and that the vector drawn from the origin to the point P_2 , that is, \mathbf{OP}_2 is given by

$$\mathbf{OP}_2 = x_2\mathbf{i}_x + y_2\mathbf{i}_y + z_2\mathbf{i}_z \quad (1.24)$$

Since, from the rule for vector addition, $\mathbf{OP}_1 + \mathbf{P}_1\mathbf{P}_2 = \mathbf{OP}_2$, we obtain

$$\mathbf{P}_1\mathbf{P}_2 = \mathbf{OP}_2 - \mathbf{OP}_1 = (x_2 - x_1)\mathbf{i}_x + (y_2 - y_1)\mathbf{i}_y + (z_2 - z_1)\mathbf{i}_z \quad (1.25)$$

In our study of electromagnetic fields, we have to work with line integrals, surface integrals, and volume integrals. As in elementary calculus, these involve differential lengths, surfaces, and volumes obtained by incrementing the coordinates by infinitesimal amounts. Since in the Cartesian coordinate system the three coordinates represent lengths, the differential length elements obtained by incrementing one coordinate at a time keeping the other two coordinates constant are $dx\mathbf{i}_x$, $dy\mathbf{i}_y$, and $dz\mathbf{i}_z$ for the x , y , and z coordinates, respectively, as shown in Fig. 1.6(d), at an arbitrary point $P(x, y, z)$. The three differential length elements form the contiguous edges of a rectangular box in which the corner Q diagonally opposite to P has the coordinates $(x + dx, y + dy, z + dz)$. The differential length vector $d\mathbf{l}$ from P to Q is simply the vector sum of the three differential length elements. Thus

$$d\mathbf{l} = dx\mathbf{i}_x + dy\mathbf{i}_y + dz\mathbf{i}_z \quad (1.26)$$

The box has six differential surfaces with each surface defined by two of the three length elements, as shown by the projections onto the coordinate planes in Fig. 1.6(d). The orientation of a differential surface dS is specified by a unit vector normal to it, that is, a unit vector perpendicular to any two vectors tangential to the surface. Unless specified, the normal vector can be drawn toward any one of the two sides of a given surface. Thus the differential surfaces formed by the pairs of differential length elements are

$$\pm dS\mathbf{i}_z = \pm dx\,dy\mathbf{i}_z = \pm dx\mathbf{i}_x \times dy\mathbf{i}_y \quad (1.27a)$$

$$\pm dS\mathbf{i}_x = \pm dy\,dz\mathbf{i}_x = \pm dy\mathbf{i}_y \times dz\mathbf{i}_z \quad (1.27b)$$

$$\pm dS\mathbf{i}_y = \pm dz\,dx\mathbf{i}_y = \pm dz\mathbf{i}_z \times dx\mathbf{i}_x \quad (1.27c)$$

Finally, the differential volume dv formed by the three differential lengths is simply the volume of the box, that is,

$$dv = dx dy dz \quad (1.28)$$

We shall now briefly review some elementary analytic geometrical details that will be useful in our study of electromagnetics. An arbitrary surface is defined by an equation of the form

$$f(x, y, z) = 0 \quad (1.29)$$

In particular, the equation for a plane surface making intercepts a , b , and c on the x , y , and z axes, respectively, is given by

$$\frac{x}{a} + \frac{y}{b} + \frac{z}{c} = 1 \quad (1.30)$$

Since a curve is the intersection of two surfaces, an arbitrary curve is defined by a pair of equations

$$f(x, y, z) = 0 \quad \text{and} \quad g(x, y, z) = 0 \quad (1.31)$$

Alternatively, a curve is specified by a set of three parametric equations

$$x = x(t), \quad y = y(t), \quad z = z(t) \quad (1.32)$$

where t is an independent parameter. For example, a straight line passing through the origin and making equal angles with the positive x , y , and z axes is given by the pair of equations $y = x$ and $z = x$, or by the set of three parametric equations $x = t$, $y = t$, and $z = t$.

Example 1.2. Let us find a unit vector normal to the plane

$$5x + 2y + 4z = 20$$

By writing the given equation for the plane in the form

$$\frac{x}{4} + \frac{y}{10} + \frac{z}{5} = 1$$

we identify the intercepts made by the plane on the x , y , and z axes to be 4, 10, and 5, respectively. The portion of the plane lying in the first octant of the coordinate system is shown in Fig. 1.7.

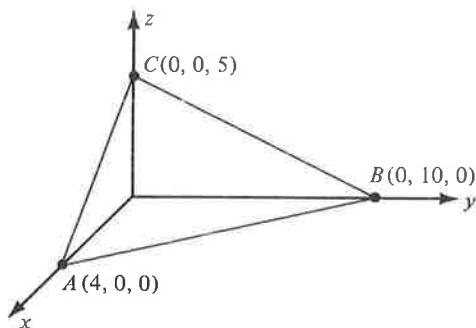

Figure 1.7. The plane surface $5x + 2y + 4z = 20$.

To find a unit vector normal to the plane, we consider two vectors lying in the plane and evaluate their cross product. Thus considering the vectors \mathbf{AB} and \mathbf{AC} , we have from (1.25),

$$\begin{aligned}\mathbf{AB} &= (0 - 4)\mathbf{i}_x + (10 - 0)\mathbf{i}_y + (0 - 0)\mathbf{i}_z = -4\mathbf{i}_x + 10\mathbf{i}_y, \\ \mathbf{AC} &= (0 - 4)\mathbf{i}_x + (0 - 0)\mathbf{i}_y + (5 - 0)\mathbf{i}_z = -4\mathbf{i}_x + 5\mathbf{i}_z\end{aligned}$$

The cross product of \mathbf{AB} and \mathbf{AC} is then given by

$$\mathbf{AB} \times \mathbf{AC} = \begin{vmatrix} \mathbf{i}_x & \mathbf{i}_y & \mathbf{i}_z \\ -4 & 10 & 0 \\ -4 & 0 & 5 \end{vmatrix} = 50\mathbf{i}_x + 20\mathbf{i}_y + 40\mathbf{i}_z$$

This vector is perpendicular to both \mathbf{AB} and \mathbf{AC} and hence to the plane. Finally, the required unit vector is obtained by dividing $\mathbf{AB} \times \mathbf{AC}$ by its magnitude. Thus it is equal to

$$\frac{50\mathbf{i}_x + 20\mathbf{i}_y + 40\mathbf{i}_z}{|50\mathbf{i}_x + 20\mathbf{i}_y + 40\mathbf{i}_z|} = \frac{5\mathbf{i}_x + 2\mathbf{i}_y + 4\mathbf{i}_z}{\sqrt{25 + 4 + 16}} = \frac{1}{3\sqrt{5}}(5\mathbf{i}_x + 2\mathbf{i}_y + 4\mathbf{i}_z) \quad \blacksquare$$

1.3 SCALAR AND VECTOR FIELDS

Before we take up the task of studying electromagnetic fields, we must understand what is meant by a “field.” A field is associated with a region in space and we say that a field exists in the region if there is a physical phenomenon associated with points in that region. For example, in everyday life we are familiar with the earth’s gravitational field. We do not “see” the field

in the same manner as we see light rays but we know of its existence in the sense that objects are acted upon by the gravitational force of the earth. In a broader context, we can talk of the field of any physical quantity as being a description, mathematical or graphical, of how the quantity varies from one point to another in the region of the field and with time. We can talk of scalar or vector fields depending on whether the quantity of interest is a scalar or a vector. We can talk of static or time-varying fields depending on whether the quantity of interest is independent of or changing with time.

We shall begin our discussion of fields with some simple examples of scalar fields. Thus let us consider the case of the conical pyramid shown in Fig. 1.8(a). A description of the height of the pyramidal surface versus position on its base is an example of a scalar field involving two variables. Choosing the origin to be the projection of the vertex of the cone onto the base and setting up an xy coordinate system to locate points on the base, we obtain the height field as a function of x and y to be

$$h(x, y) = 6 - 2\sqrt{x^2 + y^2} \quad (1.33)$$

Although we are able to depict the height variation of points on the conical surface graphically by using the third coordinate for h , we will have to be content with the visualization of the height field by a set of constant-height contours on the xy plane if only two coordinates were available, as in the case of a two-dimensional space. For the field under consideration, the constant-height contours are circles in the xy plane centered at the origin and equally spaced for equal increments of the height value as shown in Fig. 1.8(a).

For an example of a scalar field in three dimensions, let us consider a rectangular room and the distance field of points in the room from one corner of the room as shown in Fig. 1.8(b). For convenience, we choose this corner to be the origin O and set up a Cartesian coordinate system with the three contiguous edges meeting at that point as the coordinate axes. Each point in the room is defined by a set of values for the three coordinates x , y , and z . The distance r from the origin to that point is $\sqrt{x^2 + y^2 + z^2}$. Thus the distance field of points in the room from the origin is given by

$$r(x, y, z) = \sqrt{x^2 + y^2 + z^2} \quad (1.34)$$

Since the three coordinates are already used up for defining the points in the field region, we have to visualize the distance field by means of a set of constant-distance surfaces. A constant-distance surface is a surface for which points on it correspond to a particular constant value of r . For the case under consideration, the constant-distance surfaces are spherical surfaces centered

at the origin and are equally spaced for equal increments in the value of the distance as shown in Fig. 1.8(b).

The fields we have discussed thus far are static fields. A simple example of a time-varying scalar field is provided by the temperature field associated with points in a room, especially when it is being heated or cooled. Just as in the case of the distance field of Fig. 1.8(b), we set up a three-dimensional coordinate system and to each set of three coordinates corresponding to the

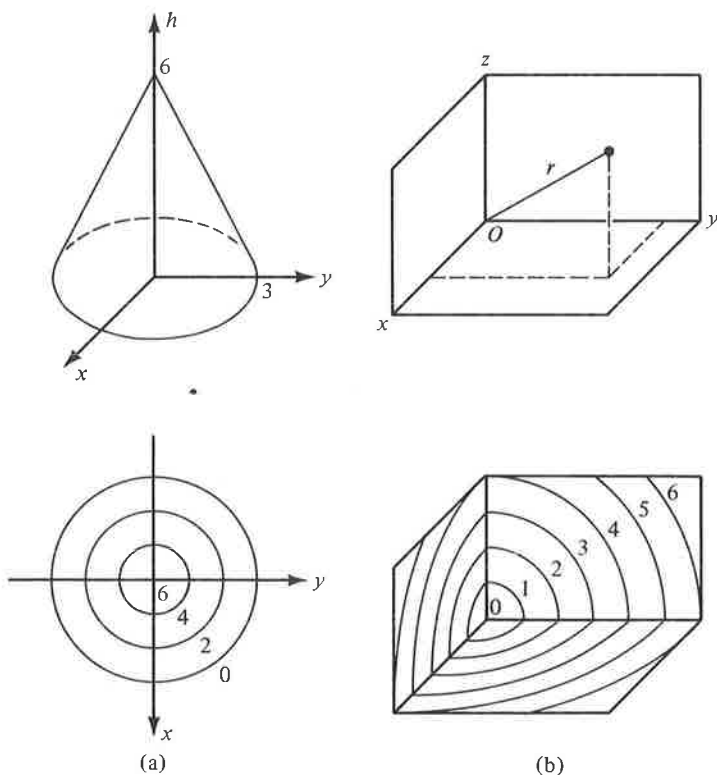

Figure 1.8. (a) A conical pyramid lying above the xy plane, and a set of constant-height contours for the conical surface. (b) A rectangular room, and a set of constant-distance surfaces depicting the distance field of points in the room from one corner of the room.

location of a point in the room, we assign a number to represent the temperature T at that point. Since the temperature at that point, however, varies with time t , this number is a function of time. Thus we describe mathematically the time-varying temperature field in the room by a function $T(x, y, z, t)$.

For any given instant of time, we can visualize a set of constant-temperature or isothermal surfaces corresponding to particular values of T as representing the temperature field for that value of time. For a different instant of time, we will have a different set of isothermal surfaces for the same values of T . Thus we can visualize the time-varying temperature field in the room by a set of isothermal surfaces continuously changing their shapes as though in a motion picture.

The foregoing discussion of scalar fields may now be extended to vector fields by recalling that a vector quantity has associated with it a direction in space in addition to magnitude. Hence in order to describe a vector field we attribute to each point in the field region a vector that represents the magnitude and direction of the physical quantity under consideration at that point. Since a vector at a given point can be expressed as the sum of its components along the set of unit vectors at that point, a mathematical description of the vector field involves simply the descriptions of the three component scalar fields. Thus for a vector field \mathbf{F} in the Cartesian coordinate system, we have

$$\mathbf{F}(x, y, z, t) = F_x(x, y, z, t)\mathbf{i}_x + F_y(x, y, z, t)\mathbf{i}_y + F_z(x, y, z, t)\mathbf{i}_z \quad (1.35)$$

Similar expressions hold in the cylindrical and spherical coordinate systems. We should, however, note that two of the unit vectors in the cylindrical coordinate system and all the unit vectors in the spherical coordinate system are themselves functions of the coordinates.

To illustrate the graphical description of a vector field, let us consider the linear velocity vector field associated with points on a circular disk rotating about its center with a constant angular velocity ω rad/s. We know that the magnitude of the linear velocity of a point on the disk is then equal to the product of the angular velocity ω and the radial distance r of the point from the center of the disk. The direction of the linear velocity is tangential to the circle drawn through that point and concentric with the disk. Hence we may depict the linear velocity field by drawing at several points on the disk vectors that are tangential to the circles concentric with the disk and passing through those points, and whose lengths are proportional to the radii of the circles, as shown in Fig. 1.9(a), where the points are carefully selected in order to reveal the circular symmetry of the field with respect to the center of the disk. We, however, find that this method of representation of the vector field results in a congested sketch of vectors. Hence we may simplify the sketch by omitting the vectors and simply placing arrowheads along the circles, giving us a set of "direction lines," also known as "stream lines" and "flux lines," which simply represent the direction of the field at points on them. We note that for the field under consideration the direction lines are also contours of constant magnitude of the velocity, and hence by

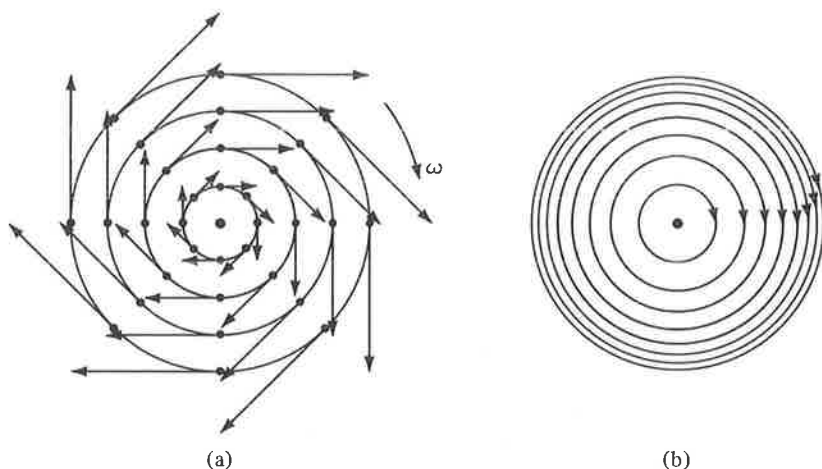

Figure 1.9. (a) Linear velocity vector field associated with points on a rotating disk. (b) Same as (a) except that the vectors are omitted, and the density of direction lines is used to indicate the magnitude variation.

increasing the density of the direction lines as r increases, we can indicate the magnitude variation, as shown in Fig. 1.9(b).

1.4 SINUSOIDALLY TIME-VARYING FIELDS

In our study of electromagnetic fields we will be particularly interested in fields that vary sinusoidally with time. Hence we shall devote this section to a discussion of sinusoidally time-varying fields. Let us first consider a scalar sinusoidal function of time. Such a function is given by an expression of the form $A \cos(\omega t + \phi)$ where A is the peak amplitude of the sinusoidal variation, $\omega = 2\pi f$ is the radian frequency, f is the linear frequency, and $(\omega t + \phi)$ is the phase. In particular, the phase of the function for $t = 0$ is ϕ . A plot of this function versus t shown in Fig. 1.10 illustrates how the function changes periodically between positive and negative values. If we now have a sinusoidally time-varying scalar field, we can visualize the field quantity varying sinusoidally with time at each point in the field region with the amplitude and phase governed by the spatial dependence of the field quantity. Thus, for example, the field $Ae^{-\alpha z} \cos(\omega t - \beta z)$ where A , α , and β are positive constants is characterized by sinusoidal time variations with amplitude decreasing exponentially with z and the phase at any given time decreasing linearly with z .

For a sinusoidally time-varying vector field, the behavior of each component of the field may be visualized in the manner just discussed. If we now

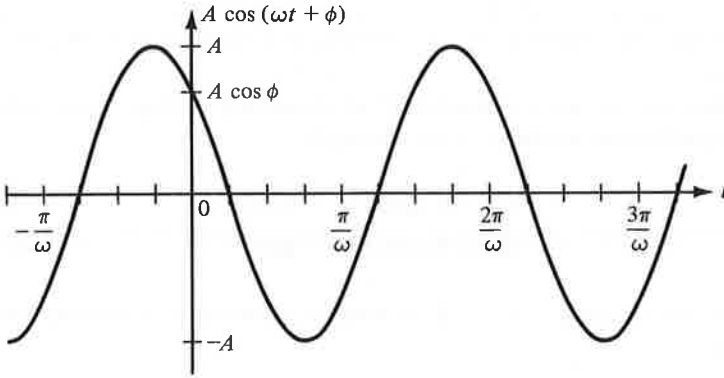

Figure 1.10. Sinusoidally time-varying scalar function $A \cos(\omega t + \phi)$.

fix our attention on a particular point in the field region, we can visualize the sinusoidal variation with time of a particular component at that point by a vector changing its magnitude and direction as shown, for example, for the x component in Fig. 1.11(a). Since the tip of the vector simply moves back and forth along a line, which in this case is parallel to the x axis, the component vector is said to be “linearly polarized” in the x direction. Similarly, the sinusoidal variation with time of the y component of the field can be visualized by a vector changing its magnitude and direction as shown in Fig. 1.11(b), not necessarily with the same amplitude and phase as those of the x component. Since the tip of the vector moves back and forth parallel

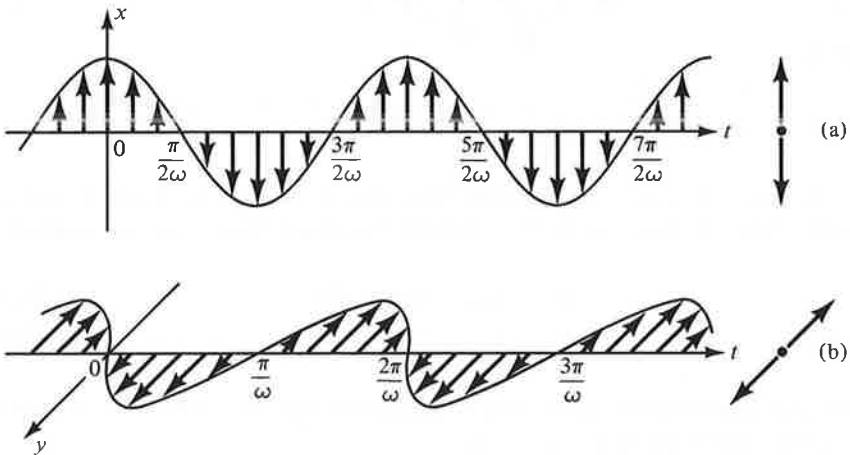

Figure 1.11. (a) Time variation of a linearly polarized vector in the x direction. (b) Time variation of a linearly polarized vector in the y direction.

to the y axis, the y component is said to be linearly polarized in the y direction. In the same manner, the z component is linearly polarized in the z direction.

If two components sinusoidally time-varying vectors have arbitrary amplitudes but are in phase as, for example,

$$\mathbf{F}_1 = F_1 \cos(\omega t + \phi) \mathbf{i}_x \quad (1.36a)$$

$$\mathbf{F}_2 = F_2 \cos(\omega t + \phi) \mathbf{i}_y \quad (1.36b)$$

then the sum vector $\mathbf{F} = \mathbf{F}_1 + \mathbf{F}_2$ is linearly polarized in a direction making an angle

$$\alpha = \tan^{-1} \frac{F_y}{F_x} = \tan^{-1} \frac{F_2}{F_1}$$

with the x direction as shown in the series of sketches in Fig. 1.12 illustrating the time history of the magnitude and direction of \mathbf{F} over an interval of one period.

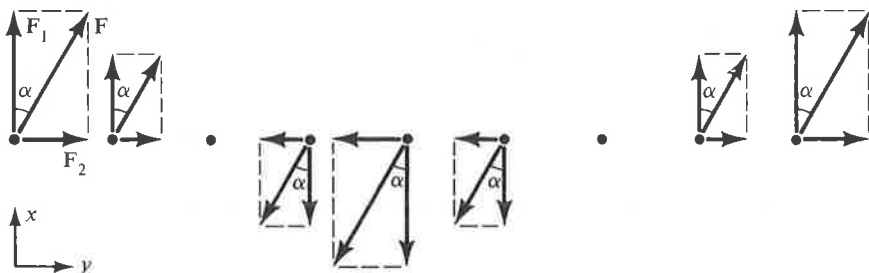

Figure 1.12. The sum vector of two linearly polarized vectors in phase is a linearly polarized vector.

If two component sinusoidally time-varying vectors have equal amplitudes, differ in direction by 90° , and differ in phase by $\pi/2$, as, for example,

$$\mathbf{F}_1 = F_0 \cos(\omega t + \phi) \mathbf{i}_x \quad (1.37a)$$

$$\mathbf{F}_2 = F_0 \sin(\omega t + \phi) \mathbf{i}_y \quad (1.37b)$$

then, to determine the “polarization” of the sum vector $\mathbf{F} = \mathbf{F}_1 + \mathbf{F}_2$, we note that the magnitude of \mathbf{F} is given by

$$|\mathbf{F}| = |F_0 \cos(\omega t + \phi) \mathbf{i}_x + F_0 \sin(\omega t + \phi) \mathbf{i}_y| = F_0 \quad (1.38)$$

and that the angle α which \mathbf{F} makes with \mathbf{i}_x is given by

$$\alpha = \tan^{-1} \frac{F_y}{F_x} = \tan^{-1} \left[\frac{F_0 \sin(\omega t + \phi)}{F_0 \cos(\omega t + \phi)} \right] = \omega t + \phi \quad (1.39)$$

Thus the sum vector rotates with constant magnitude F_0 and at a rate of ω rad/s so that its tip describes a circle. The sum vector is then said to be “circularly polarized.” The series of sketches in Fig. 1.13 illustrates the time history of the magnitude and direction of \mathbf{F} over an interval of one period.

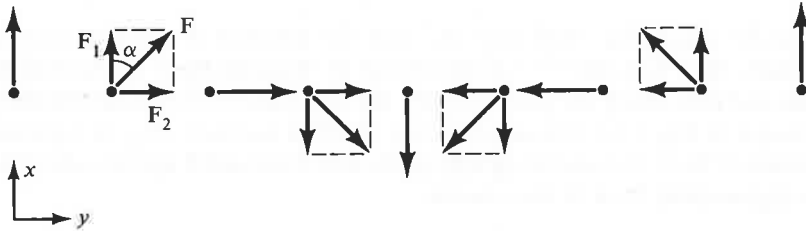

Figure 1.13. Circular polarization.

For the general case in which two component sinusoidally time-varying vectors differ in amplitude, direction, and phase by arbitrary amounts, the sum vector is “elliptically polarized,” that is, its tip describes an ellipse.

Example 1.3. Given two vectors $\mathbf{F}_1 = (3\mathbf{i}_x - 4\mathbf{i}_z) \cos \omega t$ and $\mathbf{F}_2 = 5\mathbf{i}_y \sin \omega t$, we wish to determine the polarization of the vector $\mathbf{F} = \mathbf{F}_1 + \mathbf{F}_2$.

We note that the vector \mathbf{F}_1 , consisting of two component vectors in phase, is linearly polarized with amplitude $\sqrt{3^2 + (-4)^2}$ or 5 which is equal to that of \mathbf{F}_2 . Since \mathbf{F}_1 varies as $\cos \omega t$ and \mathbf{F}_2 varies as $\sin \omega t$, they differ in phase by $\pi/2$. Also,

$$\mathbf{F}_1 \cdot \mathbf{F}_2 = (3\mathbf{i}_x - 4\mathbf{i}_z) \cdot 5\mathbf{i}_y = 0$$

so that \mathbf{F}_1 and \mathbf{F}_2 are perpendicular. Thus \mathbf{F}_1 and \mathbf{F}_2 are two linearly polarized vectors having equal amplitudes but differing in direction by 90° and differing in phase by $\pi/2$. Hence $\mathbf{F} = \mathbf{F}_1 + \mathbf{F}_2$ is circularly polarized. ■

In the remainder of this section we shall briefly review the phasor technique which, as the student may have already learned in sinusoidal steady-state circuit analysis, is very useful in carrying out mathematical manipulations involving sinusoidally time-varying quantities. Let us consider the simple problem of adding the two quantities $10 \cos \omega t$ and $10 \sin(\omega t - 30^\circ)$. To illustrate the basis behind the phasor technique, we carry out the following steps:

$$\begin{aligned}
 10 \cos \omega t + 10 \sin (\omega t - 30^\circ) &= 10 \cos \omega t + 10 \cos (\omega t - 120^\circ) \\
 &= \operatorname{Re}[10e^{j\omega t}] + \operatorname{Re}[10e^{j(\omega t - 2\pi/3)}] \\
 &= \operatorname{Re}[10e^{j0}e^{j\omega t}] + \operatorname{Re}[10e^{-j2\pi/3}e^{j\omega t}] \\
 &= \operatorname{Re}[(10e^{j0} + 10e^{-j2\pi/3})e^{j\omega t}] \\
 &= \operatorname{Re}[10e^{-j\pi/3}e^{j\omega t}] \\
 &= \operatorname{Re}[10e^{j(\omega t - \pi/3)}] \\
 &= 10 \cos (\omega t - 60^\circ) \tag{1.40}
 \end{aligned}$$

where Re stands for “real part of,” and the addition of the two complex numbers $10e^{j0}$ and $10e^{-j2\pi/3}$ is performed by locating them in the complex plane and then using the parallelogram law of addition of complex numbers, as shown in Fig. 1.14. Alternatively, the complex numbers may be expressed in terms of their real and imaginary parts and then added up for conversion into exponential form in the manner

$$\begin{aligned}
 10e^{j0} + 10e^{-j2\pi/3} &= (10 + j0) + (-5 - j8.66) \\
 &= 5 - j8.66 = \sqrt{5^2 + 8.66^2} e^{-j \tan^{-1} 8.66/5} \\
 &= 10e^{-j\pi/3} \tag{1.41}
 \end{aligned}$$

In practice, we do not write all of the steps shown in (1.40). First, we express all functions in their cosine forms and then recognize the phasor corresponding to each cosine function as the complex number having the magnitude equal to the amplitude of the cosine function and phase angle equal to the phase angle of the cosine function for $t = 0$. For the above exam-

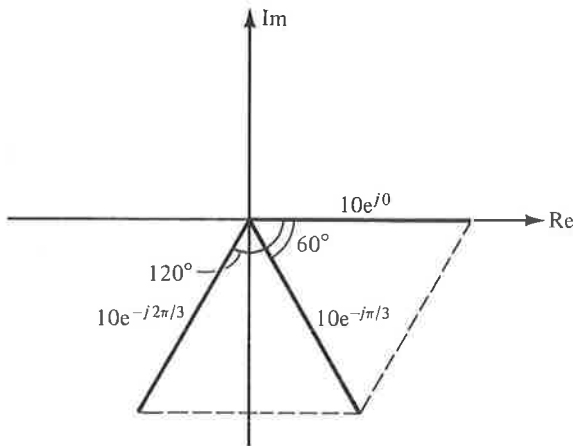

Figure 1.14. Addition of two complex numbers.

ple, the complex numbers $10e^{j0}$ and $10e^{-j2\pi/3}$ are the phasors corresponding to $10 \cos \omega t$ and $10 \sin (\omega t - 30^\circ)$, respectively. Then we add the phasors and from the sum phasor write down the required cosine function. Thus the steps involved are as shown in Fig. 1.15.

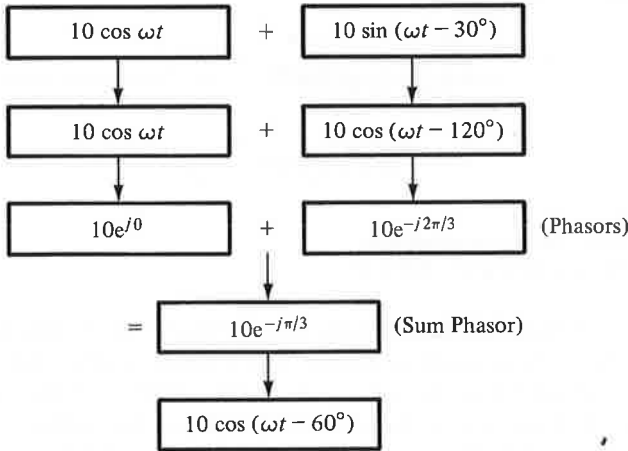

Figure 1.15. Block diagram of steps involved in the application of phasor technique to the addition of two sinusoidally time-varying functions.

The same technique is adopted for solving differential equations by recognizing, for example, that

$$\frac{d}{dt} [A \cos (\omega t + \theta)] = -A\omega \sin (\omega t + \theta) = A\omega \cos (\omega t + \theta + \pi/2)$$

and hence the phasor for $\frac{d}{dt} [A \cos (\omega t + \theta)]$ is

$$A\omega e^{j(\theta+\pi/2)} = A\omega e^{j\pi/2} e^{j\theta} = j\omega A e^{j\theta}$$

or $j\omega$ times the phasor for $A \cos (\omega t + \theta)$. Thus the differentiation operation is replaced by $j\omega$ for converting the differential equation into an algebraic equation involving phasors. To illustrate this, let us consider the differential equation

$$10^{-3} \frac{di}{dt} + i = 10 \cos 1000t \tag{1.42}$$

The solution for this is of the form $i = I_0 \cos (\omega t + \theta)$. Recognizing that $\omega = 1000$ and replacing d/dt by $j1000$ and all time functions by their phasors, we obtain the corresponding algebraic equation as

$$10^{-3} j1000 \bar{I} + \bar{I} = 10e^{j0} \tag{1.43}$$

or

$$\bar{I}(1 + j1) = 10e^{j0} \quad (1.44)$$

where the overbar above I indicates the complex nature of the quantity. Solving (1.44) for \bar{I} , we obtain

$$\bar{I} = \frac{10e^{j0}}{1 + j1} = \frac{10e^{j0}}{\sqrt{2} e^{j\pi/4}} = 7.07e^{-j\pi/4} \quad (1.45)$$

and finally

$$i = 7.07 \cos\left(1000t - \frac{\pi}{4}\right) \quad (1.46)$$

1.5 THE ELECTRIC FIELD

Basic to our study of the elements of engineering electromagnetics is an understanding of the concepts of electric and magnetic fields. Hence we shall devote this and the following section to an introduction of the electric and magnetic fields. From our study of Newton's law of gravitation in elementary physics, we are familiar with the gravitational force field associated with material bodies by virtue of their physical property known as "mass." Newton's experiments showed that the gravitational force of attraction between two bodies of masses m_1 and m_2 separated by a distance R , which is very large compared to their sizes, is equal to $m_1 m_2 G/R^2$ where G is the constant of universal gravitation. In a similar manner, a force field known as the "electric field" is associated with bodies that are "charged." A material body may be charged positively or negatively or may possess no net charge. In the International System of Units which we shall use throughout this book, the unit of charge is coulomb, abbreviated C. The charge of an electron is -1.60219×10^{-19} C. Alternatively, approximately 6.24×10^{18} electrons represent a charge of one negative coulomb.

Experiments conducted by Coulomb showed that the following hold for two charged bodies that are very small in size compared to their separation so that they can be considered as "point charges":

1. The magnitude of the force is proportional to the product of the magnitudes of the charges.
2. The magnitude of the force is inversely proportional to the square of the distance between the charges.
3. The magnitude of the force depends on the medium.
4. The direction of the force is along the line joining the charges.
5. Like charges repel; unlike charges attract.

For free space, the constant of proportionality is $1/4\pi\epsilon_0$ where ϵ_0 is known

as the permittivity of free space, having a value 8.854×10^{-12} or approximately equal to $10^{-9}/36\pi$. Thus if we consider two point charges Q_1 C and Q_2 C separated R m in free space, as shown in Fig. 1.16, then the forces F_1 and F_2 experienced by Q_1 and Q_2 , respectively, are given by

$$\mathbf{F}_1 = \frac{Q_1 Q_2}{4\pi\epsilon_0 R^2} \mathbf{i}_{21} \quad (1.47a)$$

and

$$\mathbf{F}_2 = \frac{Q_2 Q_1}{4\pi\epsilon_0 R^2} \mathbf{i}_{12} \quad (1.47b)$$

where \mathbf{i}_{21} and \mathbf{i}_{12} are unit vectors along the line joining Q_1 and Q_2 as shown in Fig. 1.16. Equations (1.47a) and (1.47b) represent Coulomb's law. Since the units of force are newtons, we note that ϵ_0 has the units (coulomb)² per (newton-meter²). These are commonly known as "farads per meter" where a farad is (coulomb)² per newton-meter.

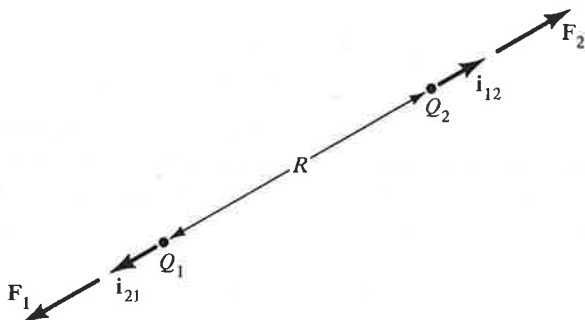

Figure 1.16. Forces experienced by two point charges Q_1 and Q_2 .

In the case of the gravitational field of a material body, we define the gravitational field intensity as the force per unit mass experienced by a small test mass placed in that field. In a similar manner, the force per unit charge experienced by a small test charge placed in an electric field is known as the "electric field intensity," denoted by the symbol \mathbf{E} . Alternatively, if in a region of space, a test charge q experiences a force \mathbf{F} , then the region is said to be characterized by an electric field of intensity \mathbf{E} given by

$$\mathbf{E} = \frac{\mathbf{F}}{q} \quad (1.48)$$

The unit of electric field intensity is newton per coulomb, or more commonly volt per meter, where a volt is newton-meter per coulomb. The test charge should be so small that it does not alter the electric field in which it is

placed. Ideally, \mathbf{E} is defined in the limit that q tends to zero, that is,

$$\mathbf{E} = \lim_{q \rightarrow 0} \frac{\mathbf{F}}{q} \quad (1.49)$$

Equation (1.49) is the defining equation for the electric field intensity irrespective of the source of the electric field. Just as one body by virtue of its mass is the source of a gravitational field acting upon other bodies by virtue of their masses, a charged body is the source of an electric field acting upon other charged bodies. We will, however, learn in Chap. 2 that there exists another source for the electric field, namely, a time-varying magnetic field.

Returning now to Coulomb's law and letting one of the two charges in Fig. 1.16, say Q_2 , be a small test charge q , we have

$$\mathbf{F}_2 = \frac{Q_1 q}{4\pi\epsilon_0 R^2} \mathbf{i}_{12} \quad (1.50)$$

The electric field intensity \mathbf{E}_2 at the test charge due to the point charge Q_1 is then given by

$$\mathbf{E}_2 = \frac{\mathbf{F}_2}{q} = \frac{Q_1}{4\pi\epsilon_0 R^2} \mathbf{i}_{12} \quad (1.51)$$

Generalizing this result by making R a variable, that is, by moving the test charge around in the medium, writing the expression for the force experienced by it, and dividing the force by the test charge, we obtain the electric field intensity \mathbf{E} of a point charge Q to be

$$\mathbf{E} = \frac{Q}{4\pi\epsilon_0 R^2} \mathbf{i}_R \quad (1.52)$$

where R is the distance from the point charge to the point at which the field intensity is to be computed and \mathbf{i}_R is the unit vector along the line joining the two points under consideration and directed away from the point charge. The electric field intensity due to a point charge is thus directed everywhere radially away from the point charge and its constant-magnitude surfaces are spherical surfaces centered at the point charge, as shown in Fig. 1.17.

If we now have several point charges Q_1, Q_2, \dots , as shown in Fig. 1.18, the force experienced by a test charge situated at a point P is the vector sum of the forces experienced by the test charge due to the individual charges. It then follows that the electric field intensity at point P is the superposition of the electric field intensities due to the individual charges, that is,

$$\mathbf{E} = \frac{Q_1}{4\pi\epsilon_0 R_1^2} \mathbf{i}_{R_1} + \frac{Q_2}{4\pi\epsilon_0 R_2^2} \mathbf{i}_{R_2} + \dots + \frac{Q_n}{4\pi\epsilon_0 R_n^2} \mathbf{i}_{R_n} \quad (1.53)$$

Let us now consider an example.

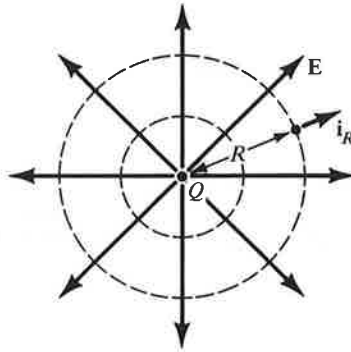

Figure 1.17. Direction lines and constant-magnitude surfaces of electric field due to a point charge.

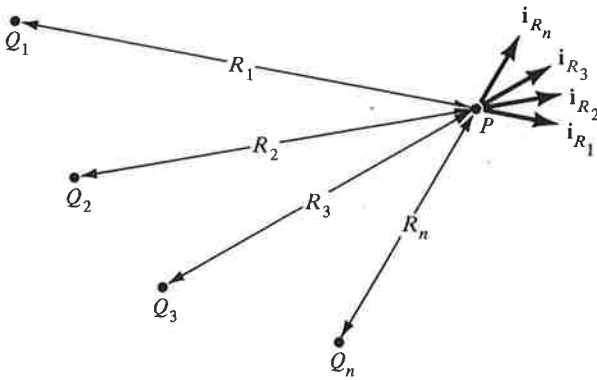

Figure 1.18. A collection of point charges and unit vectors along the directions of their electric fields at a point P.

Example 1.4. Figure 1.19 shows eight point charges situated at the corners of a cube. We wish to find the electric field intensity at each point charge, due to the remaining seven point charges.

First we note from (1.52) that the electric field intensity at a point $B(x_2, y_2, z_2)$ due to a point charge Q at point $A(x_1, y_1, z_1)$ is given by

$$\begin{aligned} \mathbf{E}_B &= \frac{Q}{4\pi\epsilon_0(AB)^2} \mathbf{i}_{AB} = \frac{Q}{4\pi\epsilon_0(AB)^2} \frac{\mathbf{AB}}{(AB)} = \frac{Q(\mathbf{AB})}{4\pi\epsilon_0(AB)^3} \\ &= \frac{Q}{4\pi\epsilon_0} \frac{(x_2 - x_1)\mathbf{i}_x + (y_2 - y_1)\mathbf{i}_y + (z_2 - z_1)\mathbf{i}_z}{[(x_2 - x_1)^2 + (y_2 - y_1)^2 + (z_2 - z_1)^2]^{3/2}} \end{aligned} \quad (1.54)$$

Let us now consider the point (1, 1, 1). Applying (1.54) to each of the charges at the seven other points and using (1.53), we obtain the electric field intensity

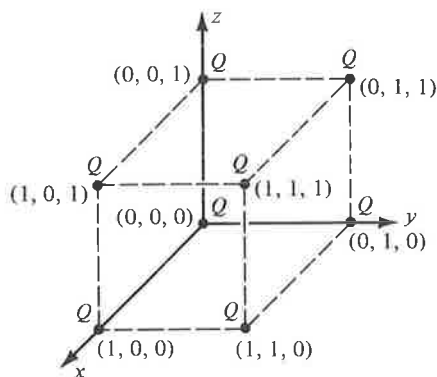

Figure 1.19. A cubical arrangement of point charges.

at the point $(1, 1, 1)$ to be

$$\begin{aligned}
 \mathbf{E}_{(1,1,1)} &= \frac{Q}{4\pi\epsilon_0} \left[\frac{\mathbf{i}_x}{(1)^{3/2}} + \frac{\mathbf{i}_y}{(1)^{3/2}} + \frac{\mathbf{i}_z}{(1)^{3/2}} + \frac{\mathbf{i}_y + \mathbf{i}_z}{(2)^{3/2}} + \frac{\mathbf{i}_z + \mathbf{i}_x}{(2)^{3/2}} \right. \\
 &\quad \left. + \frac{\mathbf{i}_x + \mathbf{i}_y}{(2)^{3/2}} + \frac{\mathbf{i}_x + \mathbf{i}_y + \mathbf{i}_z}{(3)^{3/2}} \right] \\
 &= \frac{Q}{4\pi\epsilon_0} \left(1 + \frac{1}{\sqrt{2}} + \frac{1}{3\sqrt{3}} \right) (\mathbf{i}_x + \mathbf{i}_y + \mathbf{i}_z) \\
 &= \frac{3.29Q}{4\pi\epsilon_0} \left(\frac{\mathbf{i}_x + \mathbf{i}_y + \mathbf{i}_z}{\sqrt{3}} \right)
 \end{aligned}$$

Noting that $(\mathbf{i}_x + \mathbf{i}_y + \mathbf{i}_z)/\sqrt{3}$ is the unit vector directed from $(0, 0, 0)$ to $(1, 1, 1)$, we find the electric field intensity at $(1, 1, 1)$ to be directed diagonally away from $(0, 0, 0)$, with a magnitude equal to $\frac{3.29Q}{4\pi\epsilon_0}$ N/C. From symmetry considerations, it then follows that the electric field intensity at each point charge, due to the remaining seven point charges, has a magnitude $\frac{3.29Q}{4\pi\epsilon_0}$ N/C, and it is directed away from the corner opposite to that charge. ■

The foregoing illustration of the computation of the electric field intensity due to a multitude of point charges may be extended to the computation of the field intensity for a continuous charge distribution by dividing the region in which the charge exists into elemental lengths, surfaces, or volumes depending on whether the charge is distributed along a line, over a surface, or in a volume, and treating the charge in each elemental length, surface, or volume as a point charge and then applying superposition. We shall include some of the simpler cases in the problems for the interested reader.

Let us now consider the motion of a cloud of electrons, distributed uniformly with density N , under the influence of a time-varying electric field of intensity

$$\mathbf{E} = E_0 \cos \omega t \mathbf{i}_x \tag{1.55}$$

Each electron experiences a force given by

$$\mathbf{F} = e\mathbf{E} = eE_0 \cos \omega t \mathbf{i}_x \tag{1.56}$$

where e is the charge of the electron. The equation of motion of the electron is then given by

$$m \frac{d\mathbf{v}}{dt} = eE_0 \cos \omega t \mathbf{i}_x \tag{1.57}$$

where m is the mass of the electron and \mathbf{v} is its velocity. Solving (1.57) for \mathbf{v} , we obtain

$$\mathbf{v} = \frac{eE_0}{m\omega} \sin \omega t \mathbf{i}_x + \mathbf{C} \tag{1.58}$$

where \mathbf{C} is the constant of integration. Assuming an initial condition of $\mathbf{v} = 0$ for $t = 0$ gives us $\mathbf{C} = 0$, reducing (1.58) to

$$\mathbf{v} = \frac{eE_0}{m\omega} \sin \omega t \mathbf{i}_x = -\frac{|e|E_0}{m\omega} \sin \omega t \mathbf{i}_x \tag{1.59}$$

The motion of the electron cloud gives rise to current flow. To find the current crossing an infinitesimal surface of area ΔS oriented such that the normal vector to the surface makes an angle α with the x direction as shown in Fig. 1.20, let us for instance consider an infinitesimal time interval Δt

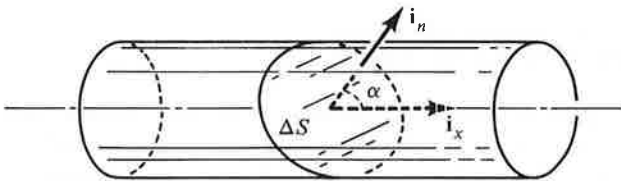

Figure 1.20. For finding the current crossing an infinitesimal area in a moving cloud of electrons.

when v_x is negative. The number of electrons crossing the area ΔS from its right side to its left side in this time interval is the same as that which exists in a column of length $|v_x| \Delta t$ and cross-sectional area $\Delta S \cos \alpha$ to the right of the area under consideration. Thus the negative charge ΔQ crossing the

area ΔS in time Δt to its left side is given by

$$\begin{aligned}\Delta Q &= (\Delta S \cos \alpha)(v_x |\Delta t|) Ne \\ &= Ne |v_x| \Delta S \cos \alpha \Delta t\end{aligned}\quad (1.60)$$

The current ΔI flowing through the area ΔS from its left side to its right side is then given by

$$\begin{aligned}\Delta I &= \frac{|\Delta Q|}{\Delta t} = N |e| |v_x| \Delta S \cos \alpha \\ &= \frac{N |e|^2}{m\omega} E_0 \sin \omega t \Delta S \cos \alpha \\ &= \frac{Ne^2}{m\omega} E_0 \sin \omega t \mathbf{i}_x \cdot \Delta S \mathbf{i}_n\end{aligned}\quad (1.61)$$

where \mathbf{i}_n is the unit vector normal to the area ΔS as shown in Fig. 1.20.

We can now talk of a current density vector \mathbf{J} , associated with the current flow. The current density vector has a magnitude equal to the current per unit area and a direction normal to the area when the area is oriented in order to maximize the current crossing it. The current crossing ΔS is maximized when $\alpha = 0$, that is, when the area is oriented such that $\mathbf{i}_n = \mathbf{i}_x$. The current per unit area is then equal to $\frac{Ne^2}{m\omega} E_0 \sin \omega t$. Thus the current density vector is given by

$$\begin{aligned}\mathbf{J} &= \frac{Ne^2}{m\omega} E_0 \sin \omega t \mathbf{i}_x \\ &= Nev\end{aligned}\quad (1.62)$$

Finally, by substituting (1.62) back into (1.61), we note that the current crossing any area $\Delta \mathbf{S} = \Delta S \mathbf{i}_n$ is simply equal to $\mathbf{J} \cdot \Delta \mathbf{S}$.

1.6 THE MAGNETIC FIELD

In the preceding section we presented an experimental law known as Coulomb's law having to do with the electric force associated with two charged bodies, and we introduced the electric field intensity vector as the force per unit charge experienced by a test charge placed in the electric field. In this section we present another experimental law known as "Ampere's law of force," analogous to Coulomb's law, and use it to introduce the magnetic field concept.

Ampere's law of force is concerned with "magnetic" forces associated with two loops of wire carrying currents by virtue of motion of charges in the loops. Figure 1.21 shows two loops of wire carrying currents I_1 and I_2

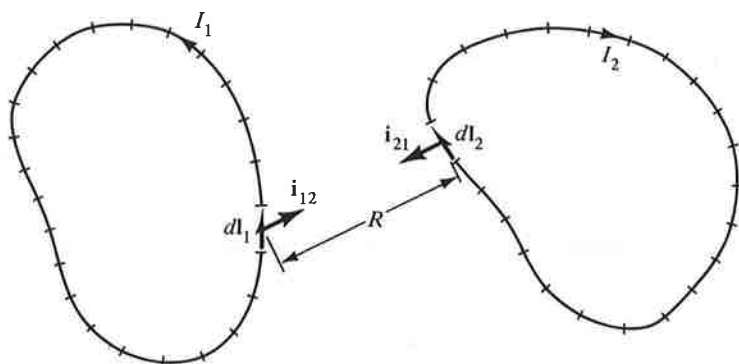

Figure 1.21. Two loops of wire carrying currents I_1 and I_2 .

and each of which is divided into a large number of elements having infinitesimal lengths. The total force experienced by a loop is the vector sum of forces experienced by the infinitesimal current elements comprising the loop. The force experienced by each of these current elements is the vector sum of the forces exerted on it by the infinitesimal current elements comprising the second loop. If the number of elements in loop 1 is m and the number of elements in loop 2 is n , then there are $m \times n$ pairs of elements. A pair of magnetic forces is associated with each pair of these elements just as a pair of electric forces is associated with a pair of point charges. Thus if we consider an element $d\mathbf{l}_1$ in loop 1 and an element $d\mathbf{l}_2$ in loop 2, then the forces $d\mathbf{F}_1$ and $d\mathbf{F}_2$ experienced by the elements $d\mathbf{l}_1$ and $d\mathbf{l}_2$, respectively, are given by

$$d\mathbf{F}_1 = I_1 d\mathbf{l}_1 \times \left(\frac{kI_2 d\mathbf{l}_2 \times \mathbf{i}_{21}}{R^2} \right) \quad (1.63a)$$

$$d\mathbf{F}_2 = I_2 d\mathbf{l}_2 \times \left(\frac{kI_1 d\mathbf{l}_1 \times \mathbf{i}_{12}}{R^2} \right) \quad (1.63b)$$

where \mathbf{i}_{21} and \mathbf{i}_{12} are unit vectors along the line joining the two current elements, R is the distance between them, and k is a constant of proportionality that depends on the medium. For free space, k is equal to $\mu_0/4\pi$ where μ_0 is known as the permeability of free space, having a value $4\pi \times 10^{-7}$. From (1.63a) or (1.63b), we note that the units of μ_0 are newtons per ampere squared. These are commonly known as "henrys per meter" where a henry is a newton-meter per ampere squared.

Equations (1.63a) and (1.63b) represent Ampere's force law as applied to a pair of current elements. Some of the features evident from these equations are as follows:

1. The magnitude of the force is proportional to the product of the two currents and to the product of the lengths of the two current elements.

2. The magnitude of the force is inversely proportional to the square of the distance between the current elements.
3. To determine the direction of the force acting on the current element $d\mathbf{l}_1$, we first find the cross product $d\mathbf{l}_2 \times \mathbf{i}_{21}$ and then cross $d\mathbf{l}_1$ into the resulting vector. Similarly, to determine the direction of the force acting on the current element $d\mathbf{l}_2$, we first find the cross product $d\mathbf{l}_1 \times \mathbf{i}_{12}$ and then cross $d\mathbf{l}_2$ into the resulting vector. For the general case of arbitrary orientations of $d\mathbf{l}_1$ and $d\mathbf{l}_2$, these operations yield $d\mathbf{F}_{12}$ and $d\mathbf{F}_{21}$ which are not equal and opposite. This is not a violation of Newton's third law since isolated current elements do not exist without sources and sinks of charges at their ends. Newton's third law, however, must and does hold for complete current loops.

The forms of (1.63a) and (1.63b) suggest that each current element is acted upon by a field which is due to the other current element. By definition, this field is the magnetic field and is characterized by a quantity known as the "magnetic flux density vector," denoted by the symbol \mathbf{B} . Thus we note from (1.63b) that the magnetic flux density at the element $d\mathbf{l}_2$ due to the element $d\mathbf{l}_1$ is given by

$$\mathbf{B}_1 = \frac{\mu_0}{4\pi} \frac{I_1 d\mathbf{l}_1 \times \mathbf{i}_{12}}{R^2} \quad (1.64)$$

and that this flux density acting upon $d\mathbf{l}_2$ results in a force on it given by

$$d\mathbf{F}_2 = I_2 d\mathbf{l}_2 \times \mathbf{B}_1 \quad (1.65)$$

Similarly, we note from (1.63a) that the magnetic flux density at the element $d\mathbf{l}_1$ due to the element $d\mathbf{l}_2$ is given by

$$\mathbf{B}_2 = \frac{\mu_0}{4\pi} \frac{I_2 d\mathbf{l}_2 \times \mathbf{i}_{21}}{R^2} \quad (1.66)$$

and that this flux density acting upon $d\mathbf{l}_1$ results in a force on it given by

$$d\mathbf{F}_1 = I_1 d\mathbf{l}_1 \times \mathbf{B}_2 \quad (1.67)$$

From (1.65) and (1.67), we see that the units of \mathbf{B} are newtons per ampere-meter, commonly known as "webers/meter²" where a weber is a newton-meter per ampere. The units of webers per unit area give the character of flux density to the quantity \mathbf{B} .

Generalizing (1.64) and (1.66), we obtain the magnetic flux density due to an infinitesimal current element of length $d\mathbf{l}$ and carrying current I to be

$$\mathbf{B} = \frac{\mu_0}{4\pi} \frac{I d\mathbf{l} \times \mathbf{i}_R}{R^2} \quad (1.68)$$

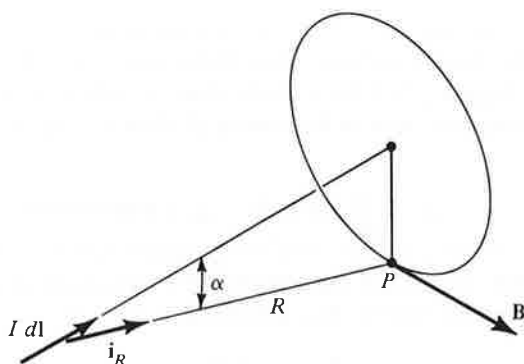

Figure 1.22. Magnetic flux density due to an infinitesimal current element.

where R is the distance from the current element to the point at which the flux density is to be computed and \mathbf{i}_R is the unit vector along the line joining the current element and the point under consideration and directed away from the current element as shown in Fig. 1.22. Equation (1.68) is known as the "Biot-Savart law" and is analogous to the expression for the electric field intensity due to a point charge. The Biot-Savart law tells us that the magnitude of \mathbf{B} at a point P is proportional to the current I , the element length dl , and the sine of the angle α between the current element and the line joining it to the point P and is inversely proportional to the square of the distance from the current element to the point P . Hence the magnetic flux density is zero at points along the axis of the current element. The direction of \mathbf{B} at point P is normal to the plane containing the current element and the line joining the current element to P as given by the cross product operation $d\mathbf{l} \times \mathbf{i}_R$, that is, right circular to the axis of the wire. As a numerical example, for a current element $0.01\mathbf{i}_z$ m situated at the origin and carrying current 2 amperes, the magnetic flux density at the point $(0, 1, 1)$ has a magnitude $10^{-9}/\sqrt{2}$ Wb/m² and is directed in the $-\mathbf{i}_x$ direction. The magnetic field due to a given current distribution can be found by dividing the current distribution into a number of infinitesimal current elements, applying the Biot-Savart law to find the magnetic field due to each current element, and then using superposition. We shall include some simple cases in the problems for the interested reader.

Turning our attention now to (1.65) and (1.67) and generalizing, we say that an infinitesimal current element of length $d\mathbf{l}$ and current I placed in a magnetic field of flux density \mathbf{B} experiences a force $d\mathbf{F}$ given by

$$d\mathbf{F} = I d\mathbf{l} \times \mathbf{B} \quad (1.69)$$

Alternatively, if a current element experiences a force in a region of space, then the region is said to be characterized by a magnetic field. Since current

is due to flow of charges, (1.69) can be formulated in terms of the moving charge causing the flow of current. Thus if the time taken by the charge dq contained in the length $d\mathbf{l}$ of the current element to flow with a velocity \mathbf{v} across the cross-sectional area of the wire is dt , then $I = dq/dt$, and $d\mathbf{l} = \mathbf{v} dt$ so that

$$d\mathbf{F} = \frac{dq}{dt} \mathbf{v} dt \times \mathbf{B} = dq \mathbf{v} \times \mathbf{B} \quad (1.70)$$

It then follows that the force \mathbf{F} experienced by a test charge q moving with a velocity \mathbf{v} in a magnetic field of flux density \mathbf{B} is given by

$$\mathbf{F} = q\mathbf{v} \times \mathbf{B} \quad (1.71)$$

We may now obtain a defining equation for \mathbf{B} in terms of the moving test charge. To do this, we note from (1.71) that the magnetic force is directed normally to both \mathbf{v} and \mathbf{B} as shown in Fig. 1.23, and that its magnitude is

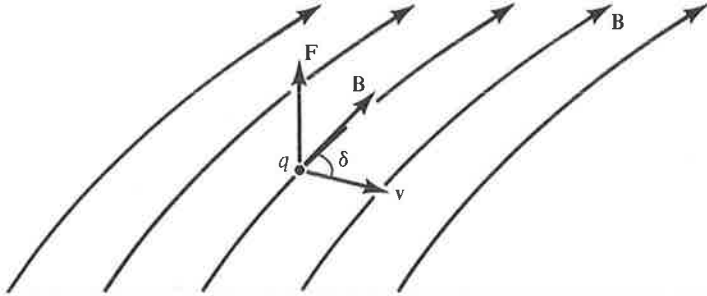

Figure 1.23. Force experienced by a test charge q moving with a velocity \mathbf{v} in a magnetic field \mathbf{B} .

equal to $qvB \sin \delta$ where δ is the angle between \mathbf{v} and \mathbf{B} . A knowledge of the force \mathbf{F} acting on a test charge moving with an arbitrary velocity \mathbf{v} provides only the value of $B \sin \delta$. To find \mathbf{B} , we must determine the maximum force qvB that occurs for δ equal to 90° by trying out several directions of \mathbf{v} , keeping its magnitude constant. Thus if this maximum force is \mathbf{F}_m and it occurs for a velocity $v\mathbf{i}_m$, then

$$\mathbf{B} = \frac{\mathbf{F}_m \times \mathbf{i}_m}{qv} \quad (1.72)$$

As in the case of defining the electric field intensity, we assume that the test charge does not alter the magnetic field in which it is placed. Ideally, \mathbf{B} is defined in the limit that qv tends to zero, that is,

$$\mathbf{B} = \text{Lim}_{qv \rightarrow 0} \frac{\mathbf{F}_m \times \mathbf{i}_m}{qv} \quad (1.73)$$

Equation (1.73) is the defining equation for the magnetic flux density irrespective of the source of the magnetic field. We have learned in this section that an electric current or a charge in motion is a source of the magnetic field. We will learn in Chap. 2 that there exists another source for the magnetic field, namely, a time-varying electric field.

We can now combine (1.48) and (1.71) to write the expression for the total force acting on a test charge q moving with a velocity \mathbf{v} in a region characterized by an electric field of intensity \mathbf{E} and a magnetic field of flux density \mathbf{B} as

$$\mathbf{F} = q\mathbf{E} + q\mathbf{v} \times \mathbf{B} = q(\mathbf{E} + \mathbf{v} \times \mathbf{B}) \quad (1.74)$$

Equation (1.74) is known as the "Lorentz force equation." We shall now consider an example.

Example 1.5. The forces experienced by a test charge q for three different velocities at a point in a region characterized by electric and magnetic fields are given by

$$\mathbf{F}_1 = q[E_0\mathbf{i}_x + (E_0 - v_0B_0)\mathbf{i}_y] \quad \text{for } \mathbf{v}_1 = v_0\mathbf{i}_x$$

$$\mathbf{F}_2 = q[(E_0 + v_0B_0)\mathbf{i}_x + E_0\mathbf{i}_y] \quad \text{for } \mathbf{v}_2 = v_0\mathbf{i}_y$$

$$\mathbf{F}_3 = q[E_0\mathbf{i}_x + E_0\mathbf{i}_y] \quad \text{for } \mathbf{v}_3 = v_0\mathbf{i}_z$$

where v_0 , E_0 , and B_0 are constants. Find \mathbf{E} and \mathbf{B} at the point.

From Lorentz force equation, we have

$$q\mathbf{E} + qv_0\mathbf{i}_x \times \mathbf{B} = q[E_0\mathbf{i}_x + (E_0 - v_0B_0)\mathbf{i}_y] \quad (1.75a)$$

$$q\mathbf{E} + qv_0\mathbf{i}_y \times \mathbf{B} = q[(E_0 + v_0B_0)\mathbf{i}_x + E_0\mathbf{i}_y] \quad (1.75b)$$

$$q\mathbf{E} + qv_0\mathbf{i}_z \times \mathbf{B} = q[E_0\mathbf{i}_x + E_0\mathbf{i}_y] \quad (1.75c)$$

Eliminating \mathbf{E} by subtracting (1.75a) from (1.75b) and (1.75c) from (1.75b), we obtain

$$(\mathbf{i}_y - \mathbf{i}_x) \times \mathbf{B} = B_0(\mathbf{i}_x + \mathbf{i}_y) \quad (1.76a)$$

$$(\mathbf{i}_y - \mathbf{i}_z) \times \mathbf{B} = B_0\mathbf{i}_x \quad (1.76b)$$

It follows from these two equations that \mathbf{B} is perpendicular to both $(\mathbf{i}_x + \mathbf{i}_y)$ and \mathbf{i}_x . Hence it is equal to $C(\mathbf{i}_x + \mathbf{i}_y) \times \mathbf{i}_x$ or $-C\mathbf{i}_z$ where C is to be determined. To do this, we substitute $\mathbf{B} = -C\mathbf{i}_z$ in (1.76a) to obtain

$$(\mathbf{i}_y - \mathbf{i}_x) \times (-C\mathbf{i}_z) = B_0(\mathbf{i}_x + \mathbf{i}_y)$$

$$-C(\mathbf{i}_x + \mathbf{i}_y) = B_0(\mathbf{i}_x + \mathbf{i}_y)$$

or $C = -B_0$. Thus we get

$$\mathbf{B} = B_0\mathbf{i}_z$$

Substituting this result in (1.75c), we obtain

$$\mathbf{E} = E_0(\mathbf{i}_x + \mathbf{i}_y) \quad \blacksquare$$

1.7 SUMMARY

We first learned in this chapter several rules of vector algebra that are necessary for our study of the elements of engineering electromagnetics by considering vectors expressed in terms of their components along three mutually orthogonal directions. To carry out the manipulations involving vectors at different points in space in a systematic manner, we then introduced the Cartesian coordinate system and discussed the application of the vector algebraic rules to vectors in the Cartesian coordinate system. To summarize these rules, we consider three vectors

$$\mathbf{A} = A_x\mathbf{i}_x + A_y\mathbf{i}_y + A_z\mathbf{i}_z$$

$$\mathbf{B} = B_x\mathbf{i}_x + B_y\mathbf{i}_y + B_z\mathbf{i}_z$$

$$\mathbf{C} = C_x\mathbf{i}_x + C_y\mathbf{i}_y + C_z\mathbf{i}_z$$

in a right-handed Cartesian coordinate system, that is, with $\mathbf{i}_x \times \mathbf{i}_y = \mathbf{i}_z$. We then have

$$\mathbf{A} + \mathbf{B} = (A_x + B_x)\mathbf{i}_x + (A_y + B_y)\mathbf{i}_y + (A_z + B_z)\mathbf{i}_z$$

$$\mathbf{B} - \mathbf{C} = (B_x - C_x)\mathbf{i}_x + (B_y - C_y)\mathbf{i}_y + (B_z - C_z)\mathbf{i}_z$$

$$m\mathbf{A} = mA_x\mathbf{i}_x + mA_y\mathbf{i}_y + mA_z\mathbf{i}_z$$

$$\frac{\mathbf{B}}{n} = \frac{B_x}{n}\mathbf{i}_x + \frac{B_y}{n}\mathbf{i}_y + \frac{B_z}{n}\mathbf{i}_z$$

$$|\mathbf{A}| = \sqrt{A_x^2 + A_y^2 + A_z^2}$$

$$\mathbf{i}_A = \frac{A_x}{\sqrt{A_x^2 + A_y^2 + A_z^2}}\mathbf{i}_x + \frac{A_y}{\sqrt{A_x^2 + A_y^2 + A_z^2}}\mathbf{i}_y + \frac{A_z}{\sqrt{A_x^2 + A_y^2 + A_z^2}}\mathbf{i}_z$$

$$\mathbf{A} \cdot \mathbf{B} = A_xB_x + A_yB_y + A_zB_z$$

$$\mathbf{A} \times \mathbf{B} = \begin{vmatrix} \mathbf{i}_x & \mathbf{i}_y & \mathbf{i}_z \\ A_x & A_y & A_z \\ B_x & B_y & B_z \end{vmatrix}$$

$$\mathbf{A} \cdot \mathbf{B} \times \mathbf{C} = \begin{vmatrix} A_x & A_y & A_z \\ B_x & B_y & B_z \\ C_x & C_y & C_z \end{vmatrix}$$

Other useful expressions are

$$\begin{aligned}d\mathbf{l} &= dx \mathbf{i}_x + dy \mathbf{i}_y + dz \mathbf{i}_z \\d\mathbf{S} &= \pm dx dy \mathbf{i}_z, \quad \pm dy dz \mathbf{i}_x, \quad \pm dz dx \mathbf{i}_y \\dv &= dx dy dz\end{aligned}$$

As a prelude to the introduction of electric and magnetic fields, we discussed the concepts of scalar and vector fields, static and time-varying, by means of some simple examples such as the height of points on a conical surface above its base, the temperature field of points in a room, and the velocity vector field associated with points on a disk rotating about its center. We learned about the visualization of fields by means of constant-magnitude contours or surfaces and in addition by means of direction lines in the case of vector fields. Particular attention was devoted to sinusoidally time-varying fields. Polarization of vector fields as a means of describing how the orientation of a vector at a point changes with time was discussed. The phasor technique as a means of facilitating mathematical operations involving sinusoidally time-varying quantities was reviewed.

Having obtained the necessary background vector algebraic tools and physical field concepts, we then introduced the electric and magnetic fields from considerations of experimental laws known as Coulomb's law and Ampere's force law, having to do with the electric forces between two point charges and the magnetic forces between two current elements, respectively. From these laws, we deduced the expressions for the electric field intensity \mathbf{E} due to a point charge Q and the magnetic flux density \mathbf{B} due to a current element $I d\mathbf{l}$. These expressions are

$$\begin{aligned}\mathbf{E} &= \frac{Q}{4\pi\epsilon_0 R^2} \mathbf{i}_R \\ \mathbf{B} &= \frac{\mu_0 I d\mathbf{l} \times \mathbf{i}_R}{4\pi R^2}\end{aligned}$$

where ϵ_0 and μ_0 are the permittivity and the permeability, respectively, of free space, R is the distance from the source to the point, say P , at which the field is to be computed, and \mathbf{i}_R is the unit vector directed from the source toward the point P . We learned that the electric field is a force field acting on charges merely by virtue of the property of charge. The electric force is given simply by

$$\mathbf{F} = q\mathbf{E}$$

On the other hand, the magnetic field exerts forces only on moving charges,

or current elements, as given by

$$\mathbf{F} = dq \mathbf{v} \times \mathbf{B} = I d\mathbf{l} \times \mathbf{B}$$

Combining the electric and magnetic field concepts, we finally introduced the Lorentz force equation for the force exerted on a charge q moving with a velocity \mathbf{v} in a region of electric and magnetic fields \mathbf{E} and \mathbf{B} , respectively, as

$$\mathbf{F} = q(\mathbf{E} + \mathbf{v} \times \mathbf{B})$$

REVIEW QUESTIONS

- 1.1. Give some examples of scalars.
- 1.2. Give some examples of vectors.
- 1.3. State all conditions for which $\mathbf{A} \cdot \mathbf{B} = 0$.
- 1.4. State all conditions for which $\mathbf{A} \times \mathbf{B} = 0$.
- 1.5. What is the significance of $\mathbf{A} \cdot \mathbf{B} \times \mathbf{C} = 0$?
- 1.6. Is it necessary for the reference vectors \mathbf{i}_1 , \mathbf{i}_2 , and \mathbf{i}_3 to be an orthogonal set?
- 1.7. State whether \mathbf{i}_1 , \mathbf{i}_2 , and \mathbf{i}_3 directed westward, northward, and downward, respectively, is a right-handed or a left-handed set.
- 1.8. What is the particular advantageous characteristic associated with the unit vectors in the Cartesian coordinate system?
- 1.9. How do you find a vector perpendicular to a plane?
- 1.10. How do you find the perpendicular distance from a point to a plane?
- 1.11. What is the total distance around the circumference of a circle of radius 1 m? What is the total vector distance around the circle?
- 1.12. What is the total surface area of a cube of sides 1 m? Assuming the normals to the surfaces to be directed outward of the cubical volume, what is the total vector surface area of the cube?
- 1.13. Describe briefly your concept of a scalar field and illustrate with an example.
- 1.14. Describe briefly your concept of a vector field and illustrate with an example.
- 1.15. How do you depict pictorially the gravitational field of the earth?
- 1.16. A sinusoidally time-varying vector is expressed in terms of its components along the x , y , and z axes. What is the polarization of each of the components?
- 1.17. What are the conditions for the sum of two linearly polarized sinusoidally time-varying vectors to be circularly polarized?
- 1.18. What is the polarization for the general case of the sum of two sinusoidally time-varying linearly polarized vectors having arbitrary amplitudes, phase angles, and directions?

- 1.19. Considering the second hand on your watch to be a vector, state its polarization. What is the frequency?
- 1.20. What is a phasor?
- 1.21. Is there any relationship between a phasor and a vector? Explain.
- 1.22. Describe the phasor technique of adding two sinusoidal functions of time.
- 1.23. Describe the phasor technique of solving a differential equation for the sinusoidal steady-state solution.
- 1.24. State Coulomb's law. To what law in mechanics is Coulomb's law analogous?
- 1.25. What is the definition of the electric field intensity?
- 1.26. What are the units of the electric field intensity?
- 1.27. What is the permittivity of free space? What are its units?
- 1.28. Describe the electric field due to a point charge.
- 1.29. How do you find the electric field intensity due to a continuous charge distribution?
- 1.30. How is current density defined? What are its units?
- 1.31. For a current flowing on a sheet, how would you define the current density at a point on the sheet? What are the units?
- 1.32. State Ampere's force law as applied to current elements.
- 1.33. Why is it not necessary for Newton's third law to hold for current elements?
- 1.34. What is the permeability of free space? What are its units?
- 1.35. Describe the magnetic field due to a current element.
- 1.36. How is the magnetic flux density defined in terms of force on a current element?
- 1.37. How is the magnetic flux density defined in terms of force on a moving charge?
- 1.38. What are the units of the magnetic flux density?
- 1.39. State Lorentz force equation.
- 1.40. If it is assumed that there is no electric field, the magnetic field at a point can be found from the knowledge of forces exerted on a moving test charge for two different velocities. Explain.

PROBLEMS

- 1.1. A bug starts at a point and travels 1 m northward, $\frac{1}{2}$ m eastward, $\frac{1}{4}$ m southward, $\frac{1}{8}$ m westward, $\frac{1}{16}$ m northward, and so on, making a 90° -turn to the right and halving the distance each time. (a) What is the total distance traveled by the bug? (b) Find the final position of the bug relative to its starting location. (c) Find the straight-line distance from the starting location to the final position.

1.2. Solve the following equations for \mathbf{A} , \mathbf{B} , and \mathbf{C} :

$$\mathbf{A} + \mathbf{B} + \mathbf{C} = 2\mathbf{i}_1 + 3\mathbf{i}_2 + 2\mathbf{i}_3$$

$$2\mathbf{A} + \mathbf{B} - \mathbf{C} = \mathbf{i}_1 + 3\mathbf{i}_2$$

$$\mathbf{A} - 2\mathbf{B} + 3\mathbf{C} = 4\mathbf{i}_1 + 5\mathbf{i}_2 + \mathbf{i}_3$$

- 1.3. Show that $(\mathbf{A} + \mathbf{B}) \cdot (\mathbf{A} - \mathbf{B}) = A^2 - B^2$ and that $(\mathbf{A} + \mathbf{B}) \times (\mathbf{A} - \mathbf{B}) = 2\mathbf{B} \times \mathbf{A}$. Verify the above for $\mathbf{A} = 3\mathbf{i}_1 - 5\mathbf{i}_2 + 4\mathbf{i}_3$ and $\mathbf{B} = \mathbf{i}_1 + \mathbf{i}_2 - 2\mathbf{i}_3$.
- 1.4. Given $\mathbf{A} = -2\mathbf{i}_1 + \mathbf{i}_2$, $\mathbf{B} = \mathbf{i}_1 - 2\mathbf{i}_2 + \mathbf{i}_3$, and $\mathbf{C} = 3\mathbf{i}_1 + 2\mathbf{i}_2 + \mathbf{i}_3$, find $\mathbf{A} \times (\mathbf{B} \times \mathbf{C}) + \mathbf{B} \times (\mathbf{C} \times \mathbf{A}) + \mathbf{C} \times (\mathbf{A} \times \mathbf{B})$.
- 1.5. Show that $\frac{1}{2}|\mathbf{A} \times \mathbf{B}|$ is equal to the area of the triangle having \mathbf{A} and \mathbf{B} as two of its sides. Then find the area of the triangle formed by the points $(1, 2, 1)$, $(-3, -4, 5)$, and $(2, -1, -3)$.
- 1.6. Show that $\mathbf{A} \cdot \mathbf{B} \times \mathbf{C}$ is the volume of the parallelepiped having \mathbf{A} , \mathbf{B} , and \mathbf{C} as three of its contiguous edges. Then find the volume if $\mathbf{A} = 4\mathbf{i}_x$, $\mathbf{B} = 2\mathbf{i}_x + \mathbf{i}_y + 3\mathbf{i}_z$, and $\mathbf{C} = 2\mathbf{i}_y + 6\mathbf{i}_z$. Comment on your result.
- 1.7. Given $\mathbf{i}_x \times \mathbf{A} = -\mathbf{i}_y + 2\mathbf{i}_z$ and $\mathbf{i}_y \times \mathbf{A} = \mathbf{i}_x - 2\mathbf{i}_z$, find \mathbf{A} .
- 1.8. Find the component of the vector drawn from $(5, 0, 3)$ to $(3, 3, 2)$ along the direction of the vector drawn from $(6, 2, 4)$ to $(3, 3, 6)$.
- 1.9. Find the unit vector normal to the plane $4x - 5y + 3z = 60$. Then find the distance from the origin to the plane.
- 1.10. Write the expression for the differential length vector $d\mathbf{l}$ at the point $(1, 2, 8)$ on the straight line $y = 2x$, $z = 4y$, and having the projection dx on the x axis.
- 1.11. Write the expression for the differential length vector $d\mathbf{l}$ at the point $(4, 4, 2)$ on the curve $x = y = z^2$ and having the projection dz on the z axis.
- 1.12. Write the expression for the differential surface vector $d\mathbf{S}$ at the point $(1, 1, \frac{1}{2})$ on the plane $x + 2z = 2$ and having the projection $dx dy$ on the xy plane.
- 1.13. Find two differential length vectors tangential to the surface $y = x^2$ at the point $(2, 4, 1)$ and then find a unit vector normal to the surface at that point.
- 1.14. A hemispherical bowl of radius 2 m lies with its base on the xy plane and with its center at the origin. Write the expression for the scalar field, describing the height of points on the bowl as a function of x and y .
- 1.15. A number equal to the sum of its coordinates is assigned to each point in a rectangular room having three of its contiguous edges as the coordinate axes. Draw a sketch of the constant-magnitude surfaces for the number field generated in this manner.
- 1.16. Write the expression for the vector distance of a point in a rectangular room from one corner of the room, choosing the three edges meeting at that point as the coordinate axes. Describe the vector distance field associated with the points in the room.
- 1.17. For the rotating disk of Fig. 1.9, write the expression for the linear velocity

vector field associated with the points on the disk; use an xy coordinate system with the origin at the center of the disk.

- 1.18. Given $f(z, t) = 10 \cos(2\pi \times 10^7 t - 0.1\pi z)$, (a) draw sketches of f versus z for $t = 0, \frac{1}{8} \times 10^{-7}, \frac{1}{4} \times 10^{-7}, \frac{3}{8} \times 10^{-7},$ and $\frac{1}{2} \times 10^{-7}$ s, and (b) draw sketches of f versus t for $z = 0, 2.5, 5, 7.5,$ and 10 m. From your sketches of part (a), what can you say about the function $f(z, t)$?
- 1.19. Repeat Problem 1.18 for $f(z, t) = 10 \cos(2\pi \times 10^7 t + 0.1\pi z)$.
- 1.20. Repeat Problem 1.18 for $f(z, t) = 10 \cos 2\pi \times 10^7 t \cos 0.1\pi z$.
- 1.21. For each of the following vector fields, find the polarization:
 (a) $1 \cos(\omega t + 30^\circ) \mathbf{i}_x + \sqrt{2} \cos(\omega t + 30^\circ) \mathbf{i}_y$
 (b) $1 \cos(\omega t + 30^\circ) \mathbf{i}_x + 1 \cos(\omega t - 60^\circ) \mathbf{i}_y$
 (c) $1 \cos(\omega t + 30^\circ) \mathbf{i}_x + \sqrt{2} \cos(\omega t - 60^\circ) \mathbf{i}_y$
- 1.22. Determine the polarization of the sum vector obtained by adding the two vector fields

$$\mathbf{F}_1 = (-\sqrt{3} \mathbf{i}_x + \mathbf{i}_y) \cos \omega t$$

$$\mathbf{F}_2 = \left(\frac{1}{2} \mathbf{i}_x + \frac{\sqrt{3}}{2} \mathbf{i}_y - \sqrt{3} \mathbf{i}_z \right) \sin \omega t$$

- 1.23. For the vector field $1 \cos \omega t \mathbf{i}_x + \sqrt{2} \sin \omega t \mathbf{i}_y$, draw sketches similar to those of Figs. 1.12 and 1.13 and describe the polarization.
- 1.24. Find $10 \cos(\omega t - 30^\circ) + 10 \cos(\omega t + 210^\circ)$ by using the phasor technique.
- 1.25. Find $3 \cos(\omega t + 60^\circ) - 4 \cos(\omega t + 150^\circ)$ by using the phasor technique.
- 1.26. Solve the differential equation $5 \times 10^{-6} \frac{di}{dt} + 12i = 13 \cos 10^6 t$ by using the phasor technique.
- 1.27. Two point charges each of mass m and charge q are suspended by strings of length l from a common point. Find the value of q for which the angle made by the strings at the common point is 90° .
- 1.28. Point charges Q and $-Q$ are situated at $(0, 0, 1)$ and $(0, 0, -1)$, respectively. Find the electric field intensity at (a) $(0, 0, 100)$, and (b) $(100, 0, 0)$.
- 1.29. For the point charge configuration of Example 1.4, find \mathbf{E} at the point $(2, 2, 2)$.
- 1.30. A line charge consists of charge distributed along a line just as graphite in a pencil lead. We then talk of line charge density, or charge per unit length, having the units C/m. Obtain a series expression for the electric field intensity at $(0, 1, 0)$ for a line charge situated along the z axis between $(0, 0, -1)$ and $(0, 0, 1)$ with uniform density 10^{-3} C/m by dividing the line into 100 equal segments. Consider the charge in each segment to be a point charge located at the center of the segment, and use superposition.
- 1.31. Repeat Problem 1.30, but assume the line charge density to be $10^{-3} |z|$ C/m.
- 1.32. Charge is distributed uniformly with density 10^{-3} C/m on a circular ring of radius 2 m lying in the xy plane and centered at the origin. Obtain the electric

field intensity at the point $(0, 0, 1)$ by using the procedure described in Problem 1.30.

- 1.33. A surface charge consists of charge distributed on a surface just as paint on a table top. We then talk of surface charge density or, charge per unit area, having the units C/m^2 . Obtain a series expression for the electric field intensity at $(0, 0, 1)$ for a surface charge of uniform density $10^{-3} C/m^2$ situated within the square on the xy plane having the corners $(1, 1, 0)$, $(-1, 1, 0)$, $(-1, -1, 0)$, and $(1, -1, 0)$ by dividing the square into 10,000 equal areas. Consider the charge in each area as a point charge located at the center of the area, and use superposition.
- 1.34. Repeat Problem 1.33, but assume the surface charge density to be $10^{-3} |xy^2| C/m^2$.
- 1.35. For an electron cloud of uniform density $N = 10^{12} m^{-3}$ oscillating under the influence of an electric field $\mathbf{E} = 10^{-3} \cos 2\pi \times 10^7 t \mathbf{i}_x$ V/m, find (a) the current density, and (b) the current crossing the surface $0.01(\mathbf{i}_x + \mathbf{i}_y) m^2$.
- 1.36. An object of mass m and charge q , suspended by a spring of spring constant k is acted upon by the earth's gravitational field and an electric field $E_0 \cos \omega t$ parallel to the gravitational field. Obtain the steady-state solution for the velocity of the object.
- 1.37. Find $d\mathbf{F}_1$ and $d\mathbf{F}_2$ for $I_1 d\mathbf{l}_1 = I_1 dx \mathbf{i}_x$ located at the origin and for $I_2 d\mathbf{l}_2 = I_2 dy \mathbf{i}_y$ located at $(0, 1, 0)$.
- 1.38. For an infinitesimal current element $I dx (\mathbf{i}_x + 2\mathbf{i}_y + 2\mathbf{i}_z)$ located at the point $(1, 0, 0)$, find the magnetic flux density at (a) the point $(0, 1, 1)$ and (b) the point $(2, 2, 2)$.
- 1.39. A square loop of wire of sides 0.01 m lies in the xy plane, with its sides parallel to the x and y axes and with its center at the origin. It carries a current of 1 ampere in the clockwise sense as seen along the positive z axis. Find the magnetic flux density at (a) $(0, 0, 1)$ and (b) $(0, 1, 0)$.
- 1.40. A straight wire along the z axis carries current I amperes in the positive z direction. Consider the portion of the wire lying between $(0, 0, -1)$ and $(0, 0, 1)$. By dividing this portion into 100 equal segments and using superposition, obtain a series expression for \mathbf{B} at $(0, 1, 0)$.
- 1.41. A circular loop of wire of radius 2 m is situated in the xy plane and with its center at the origin. It carries a current of 1 ampere in the clockwise sense as seen along the positive z axis. Find \mathbf{B} at $(0, 0, 1)$ by dividing the loop into a large number of equal infinitesimal segments and by using superposition.
- 1.42. Obtain the expression for the orbital frequency for an electron moving in a circular orbit normal to a uniform magnetic field of flux density B_0 Wb/m². Compute its value for B_0 equal to 5×10^{-5} .
- 1.43. A magnetic field $\mathbf{B} = B_0(\mathbf{i}_x + 2\mathbf{i}_y - 4\mathbf{i}_z)$ exists at a point. What should be the electric field at that point if the force experienced by a test charge moving with a velocity $\mathbf{v} = v_0(3\mathbf{i}_x - \mathbf{i}_y + 2\mathbf{i}_z)$ is to be zero?

- 1.44. The forces experienced by a test charge q at a point in a region of electric and magnetic fields are given as follows for three different velocities of the test charge:

$$\begin{aligned} \mathbf{F}_1 &= 0 & \text{for } \mathbf{v} &= v_0 \mathbf{i}_x \\ \mathbf{F}_2 &= 0 & \text{for } \mathbf{v} &= v_0 \mathbf{i}_y \\ \mathbf{F}_3 &= -qE_0 \mathbf{i}_x & \text{for } \mathbf{v} &= v_0(\mathbf{i}_x + \mathbf{i}_y) \end{aligned}$$

where v_0 and E_0 are constants. (a) Find \mathbf{E} and \mathbf{B} at that point. (b) Find the force experienced by the test charge for $\mathbf{v} = v_0(\mathbf{i}_x - \mathbf{i}_y)$.